

ENGINEERING SCHEDULE

CERTIFIED STEEL PORTAL FRAME SHED DESIGN IN ACCORDANCE WITH NCC 2022 FOR SITE WIND SPEED "39.42m/s", WIND REGION "A2", TERRAIN CATEGORY "1.26", IMPORTANCE LEVEL "2"

Internal Pressure: 0.5
Design Snow Load: 0.00 KPa, Roof Snow Load: 0.00 KPa

Customer: Tyson James
Site Address: 48 Horsley Rd, Oak flats NSW 2529

Main Building: Span: 6, Length: 7, Height: 2.5, Roof Pitch: 11 degrees
The length being comprised of 2 bays, the largest bay is 3.5m bays.
Left LeanTo: NA
Right LeanTo: NA

Total Kit Weight: 1037.22kg

DOMESTIC & LIGHT INDUSTRIAL STEEL PORTAL FRAME SHED STRUCTURES

This structure is designed in compliance with AS4600, AS3600 and AS1170 1 to 4 as Importance Level 2 with a Live Load of 0.25kPa as "Air Leaky Structures" providing stability when openings are prevalent.

The structures are clad with corrugated pre-painted finish, 0.42mm walls and 0.42mm roof (compliant with AS1562.1 Metal) over cold formed 450 to 550mPa galvanized steel C sections primary frames.

Primary framing is fastened together with 4.6 Class galvanized bolts adequately tensioned on ground prior to erection.

Secondary framing steel bracing, with purlins and girts lapped, are all tek fastened to primary steel with a minimum of two (2) teks per connection as specified in details.

All rainwater products are compliant with AS2179.1 (Metal).

ENGINEERING

The undersigning engineer has checked that the design of the structure complies with relevant current Australian Standards as stated above and the following i.e AS4671- 2001 Steel Reinforcing materials, AS3600 - Concrete structures. However, he will not be present during construction, neither will he conduct inspections nor construction supervision.

The class 10a buildings are designed for erection on pad footings or slab based on soil of classification "A"- "P" with minimum bearing capacity 100kPa (i.e. organic soil is to be removed to a suitable material below natural surface).

Where (suitable) fill is required to level the site, it should be placed and compacted in layers of 150mm maximum.

Concrete pad footings and slab supply and placement is to be in compliance with AS2870-2011 Residential Slabs & Footings, AS3600-2009 Concrete Structures for A2 and B2 exposure (i.e. 25mPa strength @ 28 days strength) with recommended slump 75 to 80mm for light pneumatic tyred traffic all trafficable floors.

25mm deep concrete saw cut, to be made into the surface of the concrete slab every 6m in width or length as crack control joints.

For sites where these conditions are considered to be inadequate, a customized foundation design for the structure can be supplied to suit a specific purpose.

CONSTRUCTION

Erection of the structure is to be in compliance with local and state ordinances,

Occupational Health and Safety Regulations and with plans provided.

GENERAL

The designs as portrayed on the drawings remain the intellectual property of Best Sheds Pty Ltd and are provided for building approval and construction purposes only.

SNOW LOAD

Following conditions only apply to buildings with snow loading:

- No maintenance or roof traffic permitted on the roof while there is snow present.
- No other structure to be erected within 500mm of the gutters of this building.

INTERNAL PORTALS
Column: C15015
Rafter: C15015
Knee Brace: NA
Knee Brace Length: NA
Apex Brace: NA
Apex Brace Length: NA

END PORTALS
Column: C15015
Rafter: C15015
Knee Brace: NA
Knee Brace Length: NA
Apex Brace: NA
Apex Brace Length: NA
Endwall Mullion: C15015

LEFT LEAN TO PORTALS
Internal Column: NA
Internal Rafter: NA
End Column: NA
End Rafter: NA
Knee Brace: NA
Knee Brace Length: NA

RIGHT LEAN TO PORTALS
Internal Column: NA
Internal Rafter: NA
End Column: NA
End Rafter: NA
Knee Brace: NA
Knee Brace Length: NA

NOTE: All unclad intermediate columns are always back to back (refer to drawing: Floor Plan).

PURLINS AND GIRTS		
Eave Purlin: C10010	Max Spacing: 1250	Overlap: 10%
Side Wall Girts: TH64075	Max Spacing: 1250	Overlap: 10%
Front End Wall Girts: TH64075	Max Spacing: 1250	Overlap: 10%
Back End Wall Girts: TH64075	Max Spacing: 1000	Overlap: 10%
Roof Purlins: TH64075		

NOTE: Girt spacing will vary to a maximum 1.25m where window/s are located.

FASTENERS
Sleeve Anchor Bolts: M12x75 Sleeve Anchor Yellow Zinc
Frame Bolts: M12x30 Purlin Assembly Zinc (Mild)
Frame Screws: Frame Screw 14x14x22
Cross Bracing Strap: NA
Open Bay Header Height: NA

COLOUR SCHEDULE
Roof Sheets: Slate Grey
External Wall Sheets: Smooth Cream
Roller Doors: Slate Grey
Flashings: Slate Grey
PA Doors: Slate Grey
Windows: NA

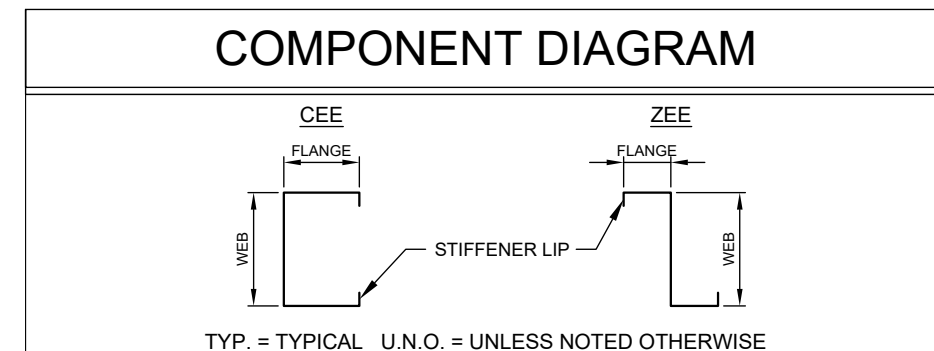

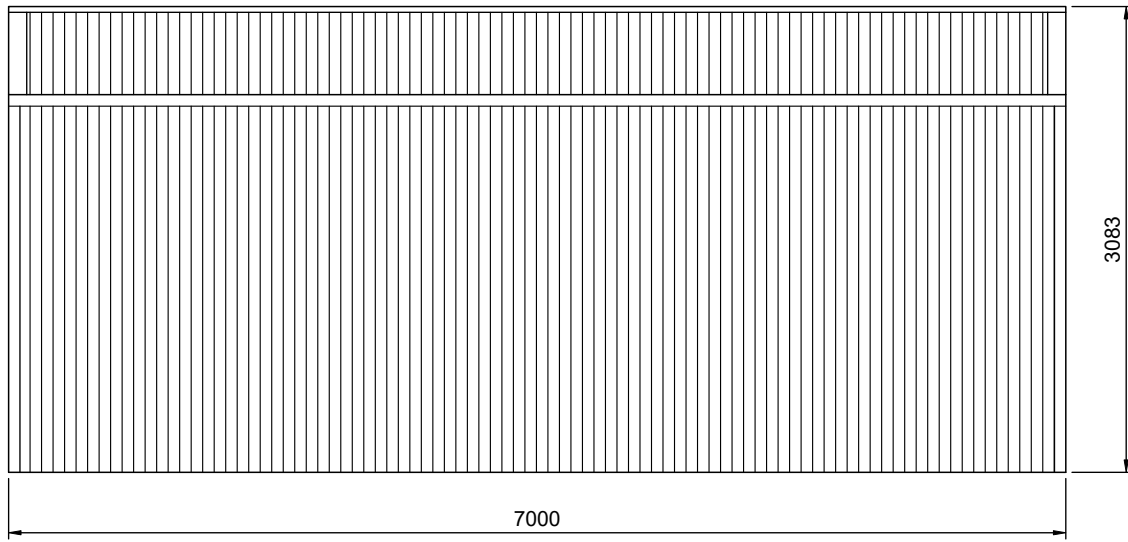

2 LEFT ELEVATION
2 SCALE: 1:50

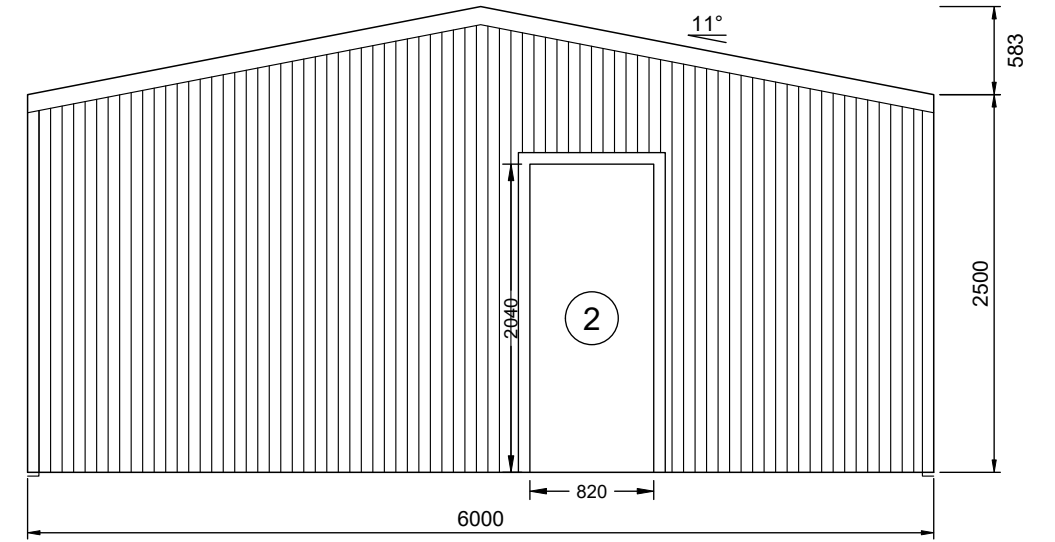

3 REAR ELEVATION
2 SCALE: 1:50

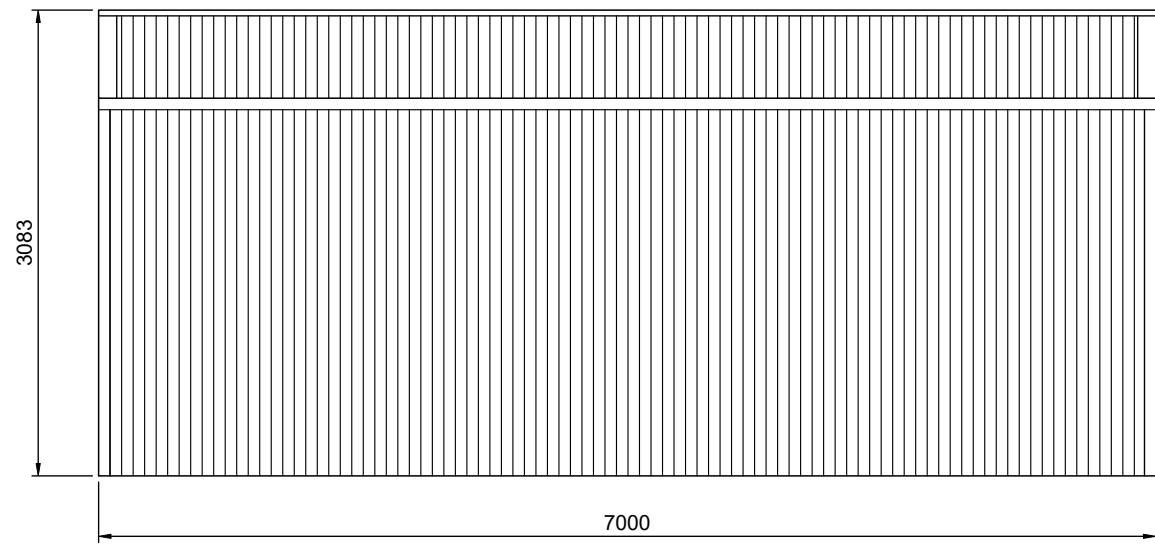

1 RIGHT ELEVATION
2 SCALE: 1:50

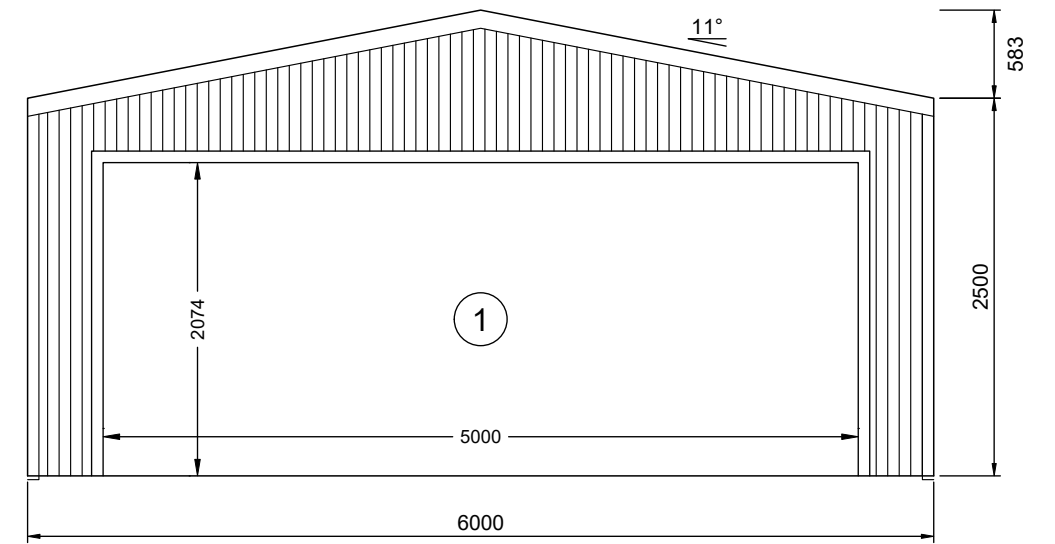

4 FRONT ELEVATION
2 SCALE: 1:50

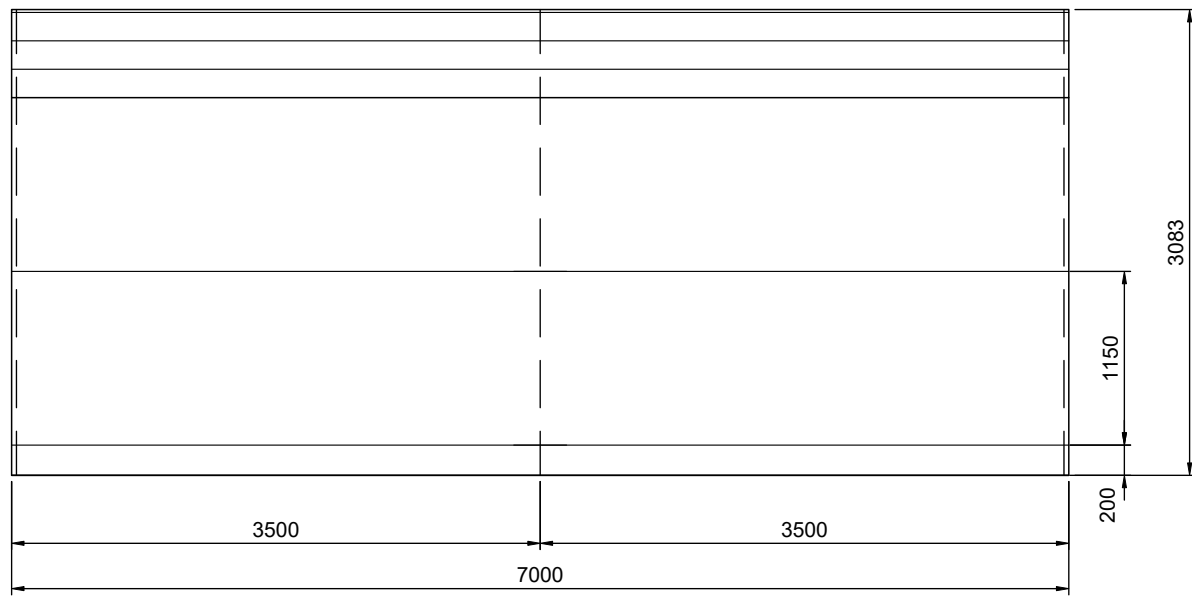

2 LEFT ELEVATION
3 SCALE: 1:50

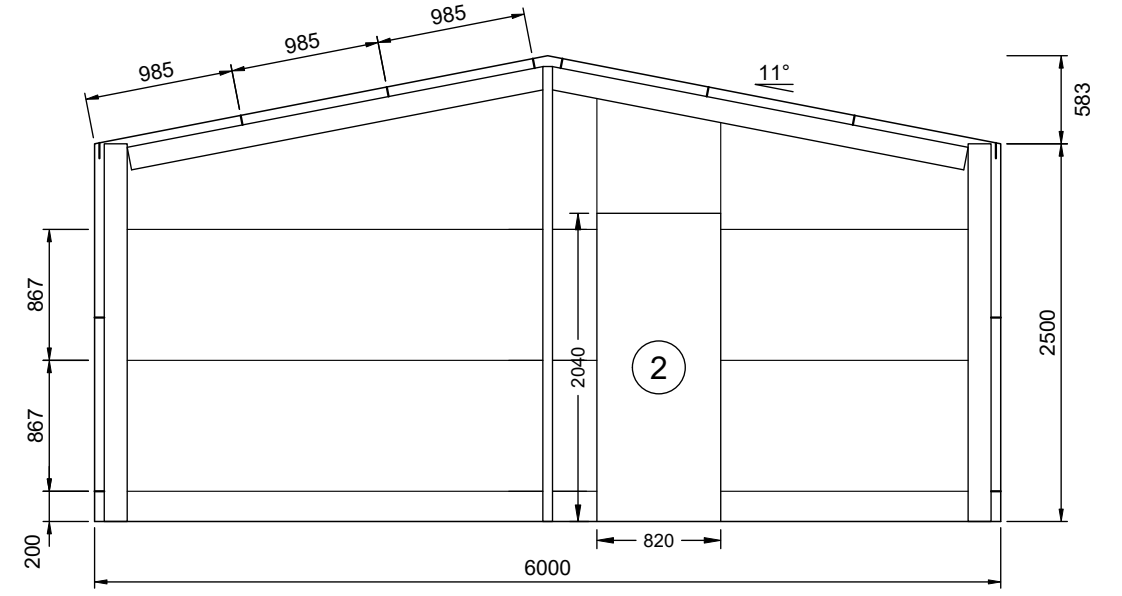

3 REAR ELEVATION
3 SCALE: 1:50 FRAME #3

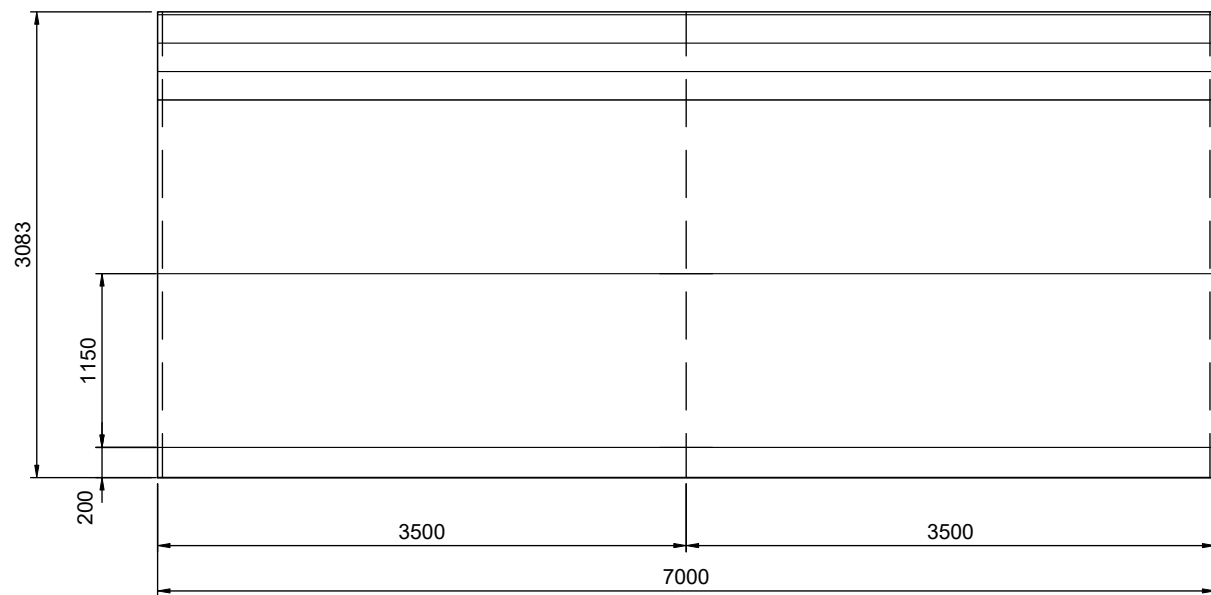

1 RIGHT ELEVATION
3 SCALE: 1:50

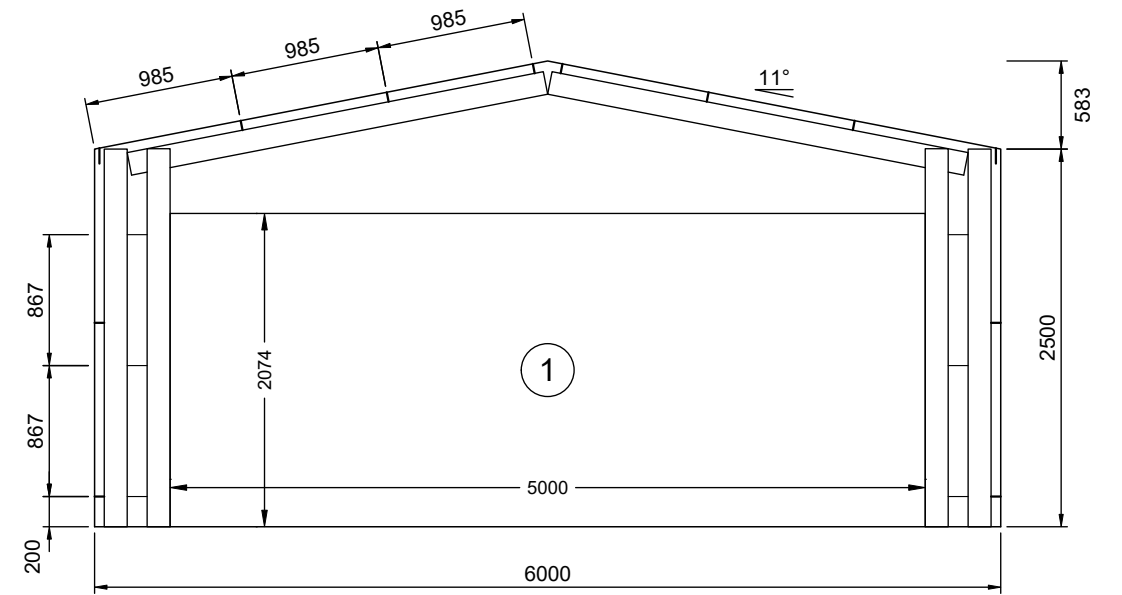

4 FRONT ELEVATION
3 SCALE: 1:50 FRAME #1

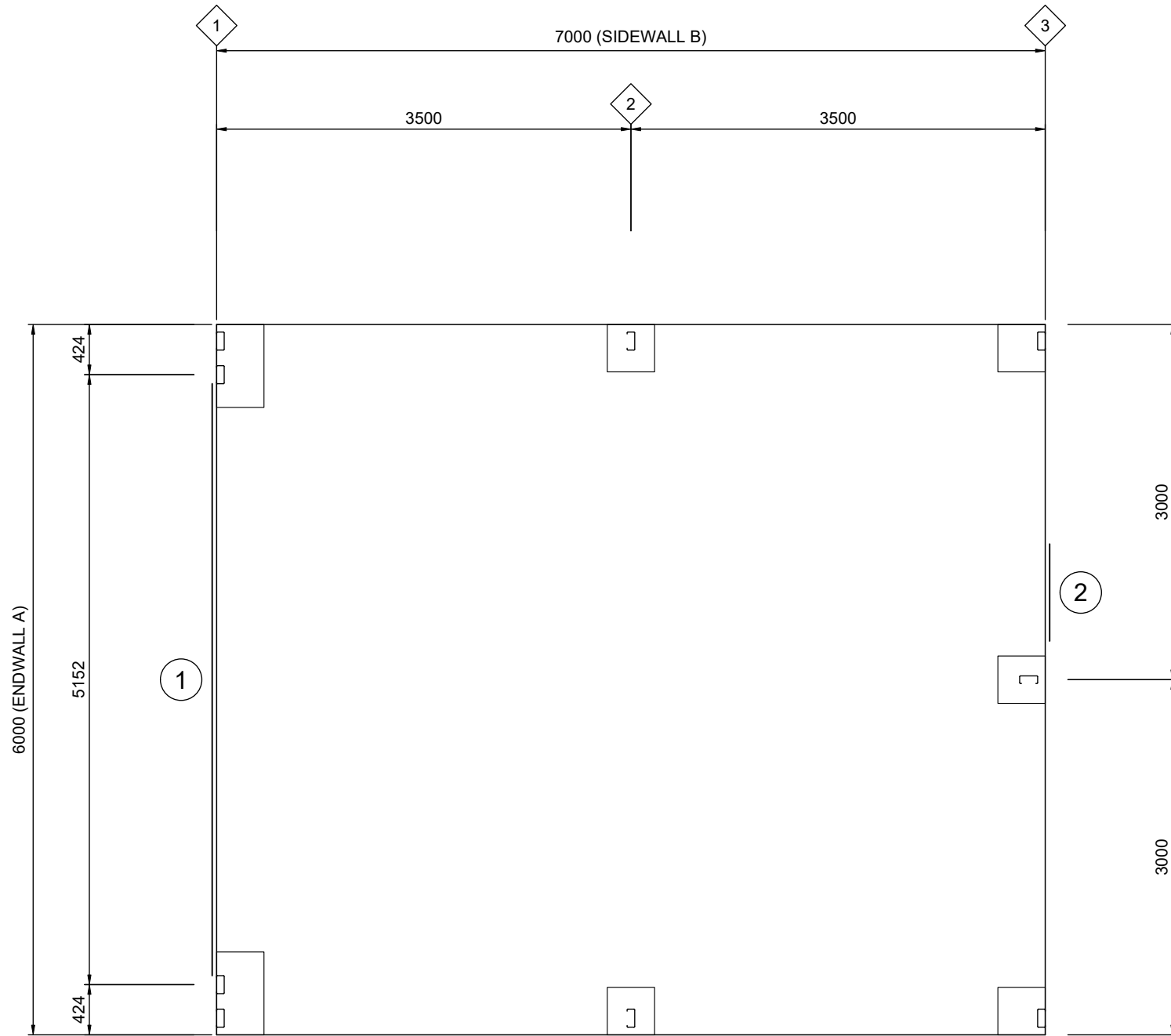

1 FLOOR PLAN
4 SCALE: 1:50

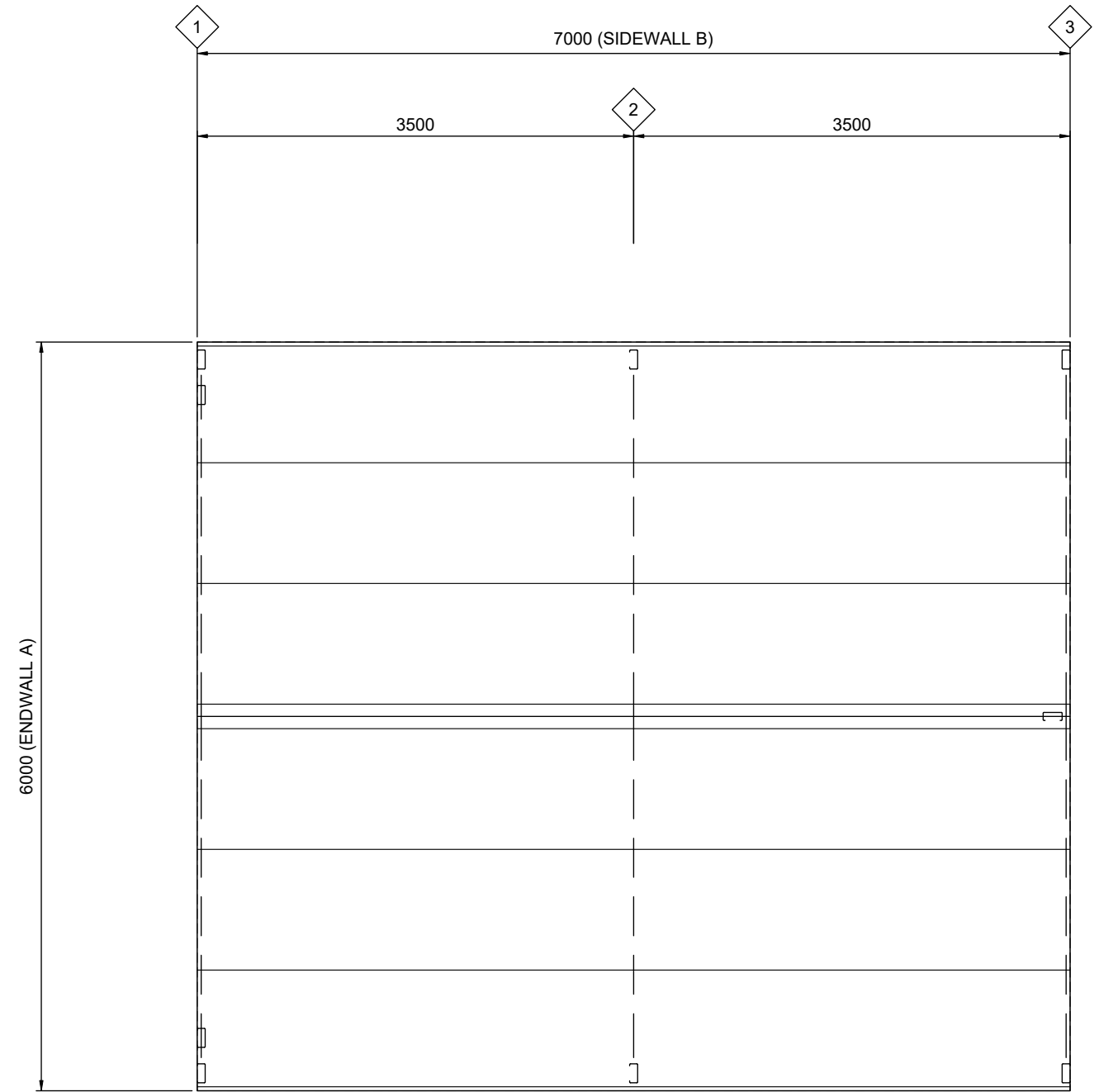

2 ROOF FRAMING PLAN
4 SCALE: 1:50

SLAB FOUNDATIONS DOMESTIC / LIGHT INDUSTRIAL (100mm MINIMUM CONCRETE SLAB INCLUDED)					
SOIL CLASSIFICATION (COMPACTED)	REINFORCING IN SLAB	EDGE BEAM	PIER	EDGE BEAM (slab thickness not included)	
	MESH REINFORCING	TRENCH MESH	Ø x DEPTH	DEPTH	WIDTH
A, S, & M	SL72	---	450 x 400	---	---
M - D	SL82	L11TM3	---	300	300
H TO H - D	SL82	L11TM3	---	400	300
E TO E - D	SL82	L11TM4	---	400	400
P (DROP EDGE BEAM OR STANDARD EDGE BEAM WITH PIERS UNDER COLUMNS 300 INTO FIRM GROUND)	SL82	L11TM4	450Ø	400	400

THICKNESS: 100MM WITH MINIMUM 30MM COVER. REFER TO SLAB FOUNDATION TABLE FOR REINFORCING SPECIFICATION

STRENGTH: 25mPa

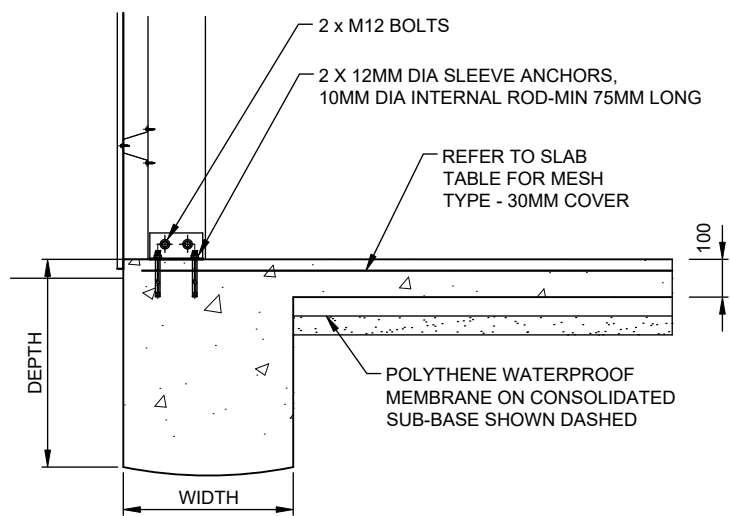

Y SLAB DETAIL

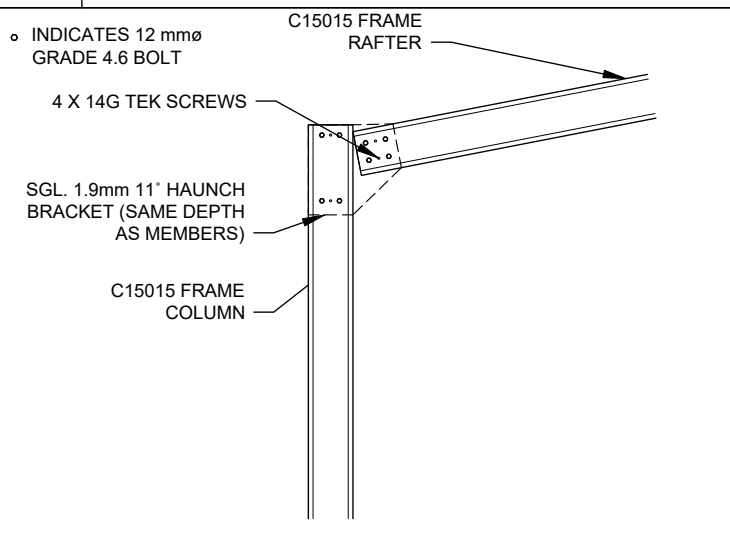

A HAUNCH CONNECTION

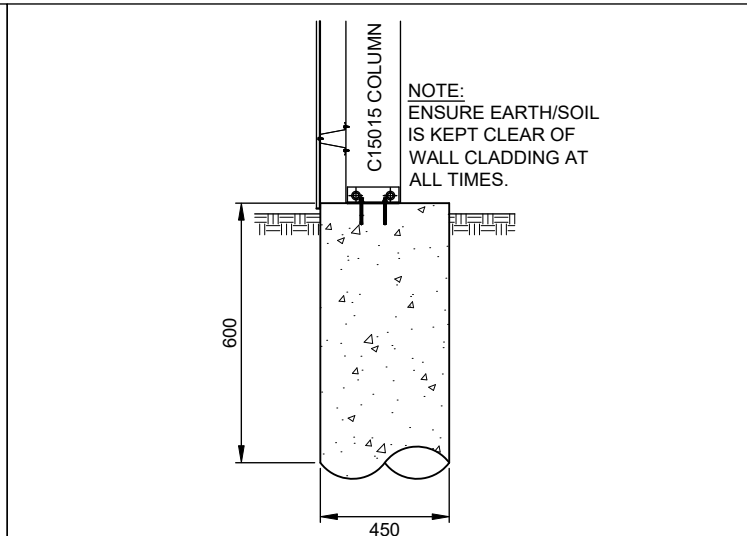

Z ALTERNATE PIER DETAIL

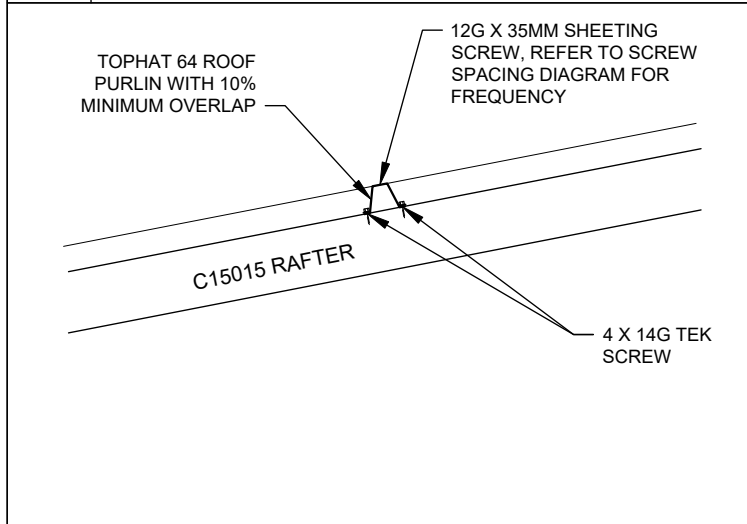

E PURLIN CONNECTION

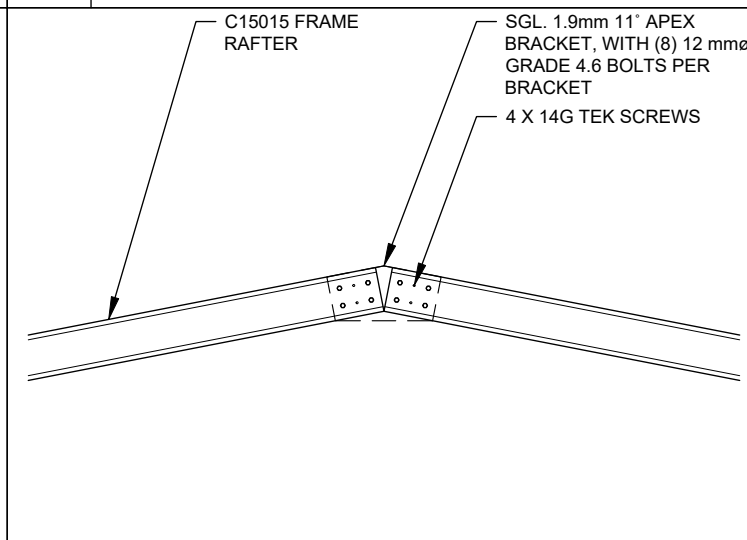

B APEX CONNECTION

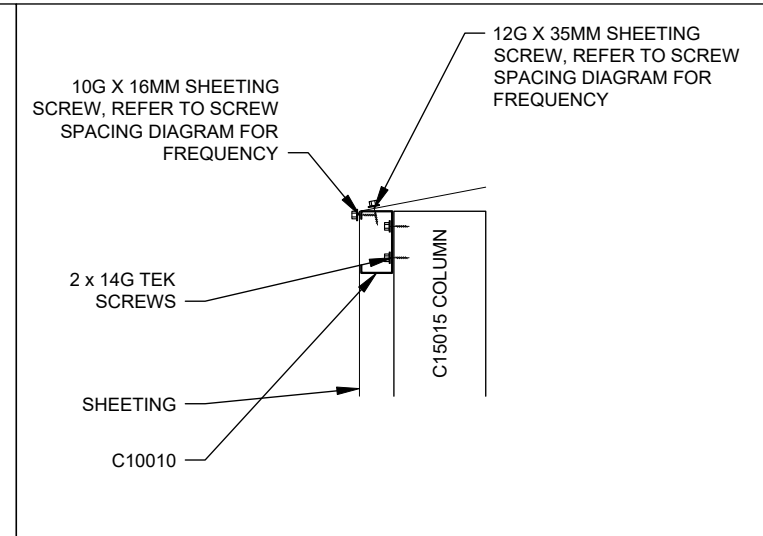

H EAVE CONNECTION

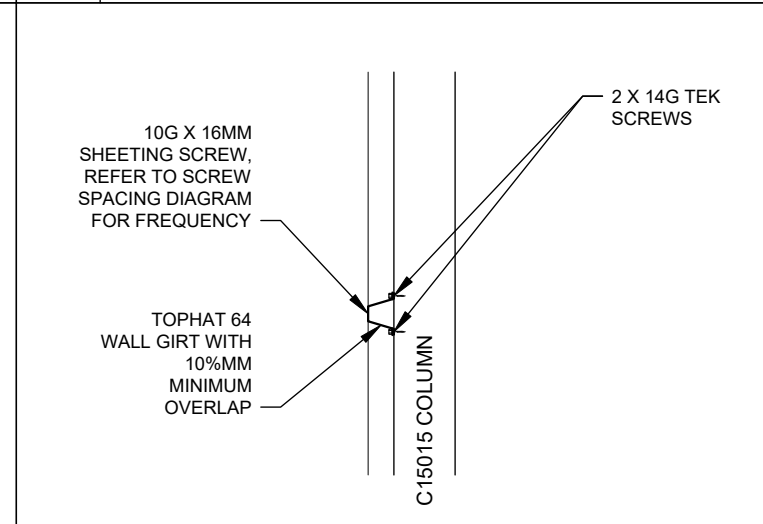

F GIRT CONNECTION

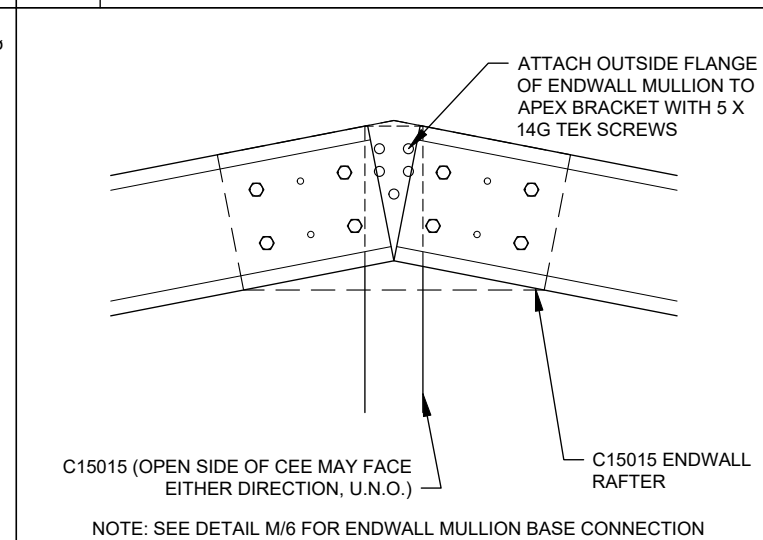

C2 ENDWALL MULLION TO RAFTER PEAK CONDITION

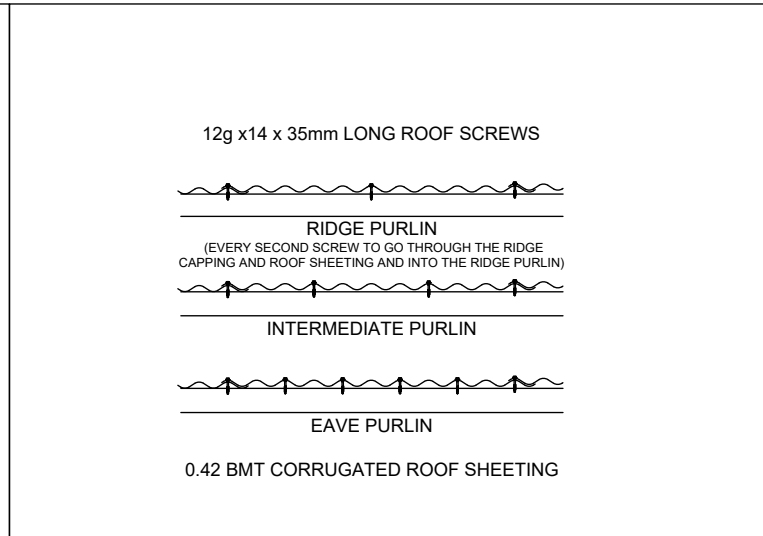

I ROOF SHEETING

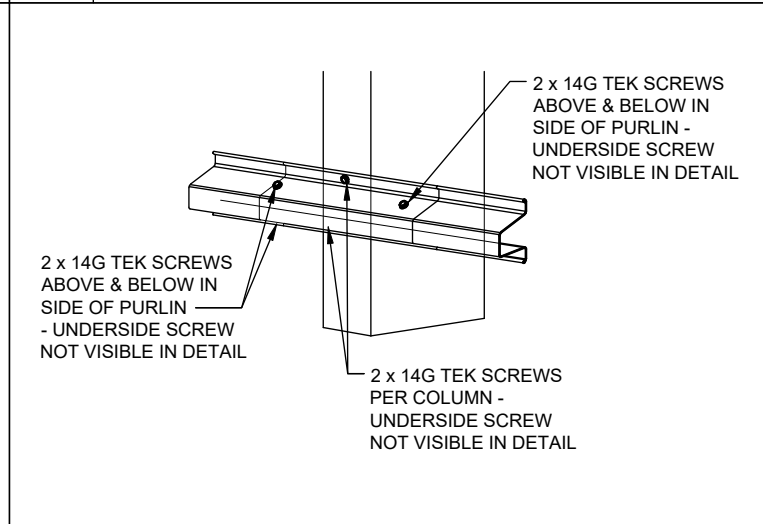

G TOP HAT CONNECTION

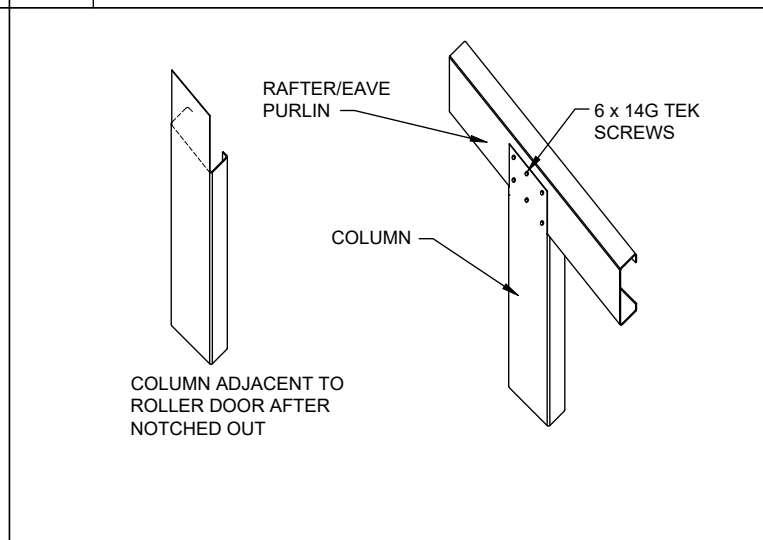

D ENDWALL MULLION ROTATED

best sheds
Value & Quality Direct to You

151 Smeaton Grange Road,
Smeaton Grange, NSW, 2567
Phone: 02 4648 7777
Fax: 02 4648 7700
Email: sales@bestsheds.com.au

EMERALD
DESIGN & CONSTRUCTION

CIVIL & STRUCTURAL ENGINEERS
COMMERCIAL - INDUSTRIAL - RESIDENTIAL - FORENSIC - STEEL DETAILING

CAMILO PINEDA MORENO
Bend MIEAust RPEng
RPEQ 15562 TBP PE003976 (VIC)

Customer Name: Tyson James
Site Address: 48 Horsley Rd
Oak flats,
NSW, 2529

Signature: *[Signature]* Date: 08.09.2025

DATE 08-09-2025
JOB NO. 2798706003
SHEET 5 of 7

N ROTATED ENDWALL MULLION BASE	O ENDWALL GIRT BRACKET	P END DOOR HEADER AND JAMB	Q PA DOOR STYLE CONNECTION
J WALL SHEETING	K CORNER COLUMN BASE	L INTERNAL COLUMN BASE	M ENDWALL MULLION BASE

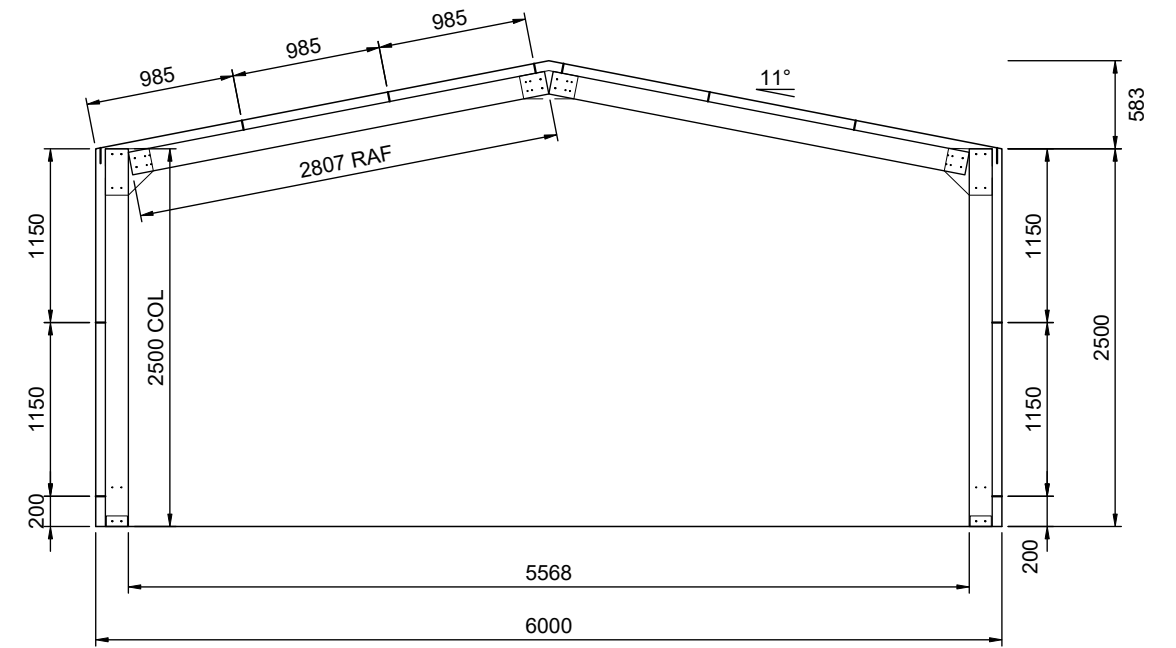

1
7
TYP. FRAME CROSS-SECTION
 SCALE: 1:50 FRAME #2