

issued for construction

- KEY TO ABBREVIATIONS**
- V VANITY
 - B BASIN
 - CSD CAVITY SLIDING DOOR
 - SHWR SHOWER
 - HP HOT PLATES
 - SSS STAINLESS STEEL SINK
 - O OVEN
 - P PAN
 - DW DISH WASHER
 - REF REFRIGERATOR
 - BS BRASS STRIP
 - BRM BROOM CUPBOARD
 - SCF STONE CLADDING WALL
 - CP CARPET
 - CT CERAMIC TILES
 - WO WATER OUTLET
 - DP DOWNPIPE
 - FFL FINISHED FLOOR LEVEL
 - RL TOP OF PAVING/TILES/FOOTPATH
 - CJ CONSTRUCTION JOINT
 - OF OVERFLOW
 - WM WASH MACHINE
 - SST STEEL TROUGH
 - CONC CONCRETE FINISH
 - MH ROOF MANHOLE
-  MAINS CONNECTED SMOKE DETECTOR AND SHALL BE INTERCONNECTED WITH BATTERY BACK AS PER BCA REQUIREMENTS

Details of the required rainwater tank (min 1000 Litres) collecting a minimum of 50 m² of roof catchment area and plumbed to a water closet, water heater or laundry cold water outlets. The tank must also be fitted with mosquito proof, non de-gradable screens, formed form not less than 315mm diameter material and have a minimum of 6 x 7 openings per cm². In the event that the tank is to be supported on a stand the stand shall be designed to be able to accommodate the imposed dead loads, wind loads and where applicable the earthquake loads as required by Clause 3.11.2 of the BCA (applicable as of July 1st 2006 BCA-SA 2.1)

NOTE: IT IS THE OWNERS RESPONSIBILITY TO CONSULT WITH RELEVANT ELECTRICITY SUPPLIERS WITH RESPECT TO HIGH VOLTAGE POWER LINES

NOTE: THERE WILL NOT BE ANY BRUSH FENCES WITHIN 3 m OF PROPOSED BUILDING WORK

NOTE: WET AREAS TO COMPLY WITH SA HOUSING CODE APPENDIX D.10.1

AREAS / sq m

main living	262.00
decks	38.00
total	104.00
total	405.00

PRIVATE OPEN SPACE: xxxx

SITE AREA: 10,012.00
SITE COVERAGE: 190.29/375
xxx SITE COVERAGE

WORKSHOP
refer to separate engineer details
13.33ES

CONTRACTORS MUST VERIFY ALL DIMENSIONS ON SITE PRIOR TO THE COMMENCEMENT OF ANY WORKS AND OR SHOP DRAWINGS. FIGURED DIMENSIONS SHALL TAKE PREFERENCE OVER SCALED DIMENSIONS.

NO.	DESCRIPTION	ISSUE	TO	DATE

18657

PASSALACQUA

10 SCHRODER COURT
NORTH HAVEN
ADELAIDE, SA

MOB 0439557709
EMAIL water@pamentpond.com.au
CONTACT salvatore passalacqua

Project
PROPOSED RESIDENCE AND SHEDS FOR MR A BIANCHETTI AT 62 WILIAMS ROAD TWO WELLS

Drawing Title
PLANS

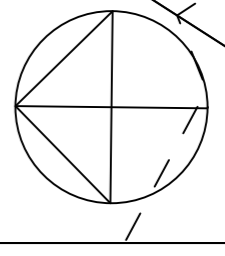

Drawn SP	Date OCT2022
Scale 1:100	Revision Date
Project Number ADAM/22/	Drawing Number 2 OF 4

