

# ENGINEERING SCHEDULE

CERTIFIED STEEL PORTAL FRAME SHED DESIGN FOR "REGION A" TERRAIN CATEGORY 2.0, 2.5 & 3.0 - IMPORTANCE LEVEL 2.

Internal Pressure: 0.7

Design Snow Load: 0.00 KPa, Roof Snow Load: 0.00 KPa

Customer: Justin Ahearn

Site Address: 2A Wellings Court, Eden NSW 2551

Main Building: Span: 6, Length: 2.2, Height: 2.4, Roof Pitch: 11 degree skillion roof

The length being comprised of 2 bays, the largest bay is 2.8m bays.

Front Garaport: Span: 6, Length: 2.8, Height: 2.4

Left LeanTo: NA

Right LeanTo: NA

Total Kit Weight: 1037.16kg

## DOMESTIC & LIGHT INDUSTRIAL STEEL PORTAL FRAME SHED STRUCTURES

This structure is designed in compliance with AS4600, AS3600 and AS1170 1 to 4 as Importance Level 2 with a Live Load of 0.25kPa as "Air Leaky Structures" providing stability when openings are prevalent.

The structures are clad with corrugated pre-painted finish, 0.42mm walls and 0.42mm roof (compliant with AS1562.1 Metal) over cold formed 450 to 550mPa galvanized steel C sections primary frames.

Primary framing is fastened together with 4.6 Class galvanized bolts adequately tensioned on ground prior to erection.

Secondary framing steel bracing, with purlins and girts lapped, are all tek fastened to primary steel with a minimum of two (2) teks per connection as specified in details.

All rainwater products are compliant with AS2179.1 (Metal).

## ENGINEERING

The undersigning engineer has checked that the design of the structure complies with relevant current Australian Standards as stated above and the following i.e AS4671- 2001 Steel Reinforcing materials, AS3600 - Concrete structures. However, he will not be present during construction, neither will he conduct inspections nor construction supervision.

The class 10a buildings are designed for erection on pad footings or slab based on soil of classification "A"- "P" with minimum bearing capacity 100kPa (i.e. organic soil is to be removed to a suitable material below natural surface).

Where (suitable) fill is required to level the site, it should be placed and compacted in layers of 150mm maximum.

Concrete pad footings and slab supply and placement is to be in compliance with AS2870-2011 Residential Slabs & Footings, AS3600-2009 Concrete Structures for A2 and B2 exposure (i.e. 25mPa strength @ 28 days strength) with recommended slump 75 to 80mm for light pneumatic tyred traffic all trafficable floors.

For sites where these conditions are considered to be inadequate, a customized foundation design for the structure can be supplied to suit a specific purpose.

## CONSTRUCTION

Erection of the structure is to be in compliance with local and state ordinances,

Occupational Health and Safety Regulations and with plans provided.

## GENERAL

The designs as portrayed on the drawings remain the intellectual property of Best Sheds Pty Ltd and are provided for building approval and construction purposes only and are only valid when blue ink signed and dated by the engineer.

## SNOW LOAD

Following conditions only apply to buildings with snow loading:

- No maintenance or roof traffic permitted on the roof while there is snow present.
- No other structure to be erected within 500mm of the gutters of this building.

INTERNAL PORTALS
Column: NA
Rafter: NA
Knee Brace: NA
Knee Brace Length: NA
Apex Brace: NA
Apex Brace Length: NA

END PORTALS
Column: C15024
Rafter: C15024
Knee Brace: NA
Knee Brace Length: NA
Apex Brace: NA
Apex Brace Length: NA
Endwall Mullion: C15024

LEFT LEAN TO PORTALS
Internal Column: NA
Internal Rafter: NA
End Column: NA
End Rafter: NA
Knee Brace: NA
Knee Brace Length: NA

RIGHT LEAN TO PORTALS
Internal Column: NA
Internal Rafter: NA
End Column: NA
End Rafter: NA
Knee Brace: NA
Knee Brace Length: NA

NOTE: All unclad intermediate columns are always back to back (refer to drawing: Floor Plan).

PURLINS AND GIRTS		
Eave Purlin: C10010		
Side Wall Girts: TH64100	Max Spacing: 1100	Overlap: 10%
Front End Wall Girts: TH64100	Max Spacing: 1100	Overlap: 10%
Back End Wall Girts: TH64100	Max Spacing: 1100	Overlap: 10%
Roof Purlins: TH64100	Max Spacing: 1000	Overlap: 10%

NOTE: Girt spacing will vary to a maximum 1.1m where window/s are located.

FASTENERS
Sleeve Anchor Bolts: M12x80 Sleeve Anchor Yellow Zinc
Frame Bolts: M12x30 Purlin Assembly Zinc (Mild)
Frame Screws: Frame Screw 14x14x22
Cross Bracing Strap: NA
Open Bay Header Height: NA

COLOUR SCHEDULE
Roof Sheets: Slate Grey
External Wall Sheets: Slate Grey
Roller Doors: Mist Green
Flashings: Mist Green
PA Doors: Slate Grey
Windows: Mist Green

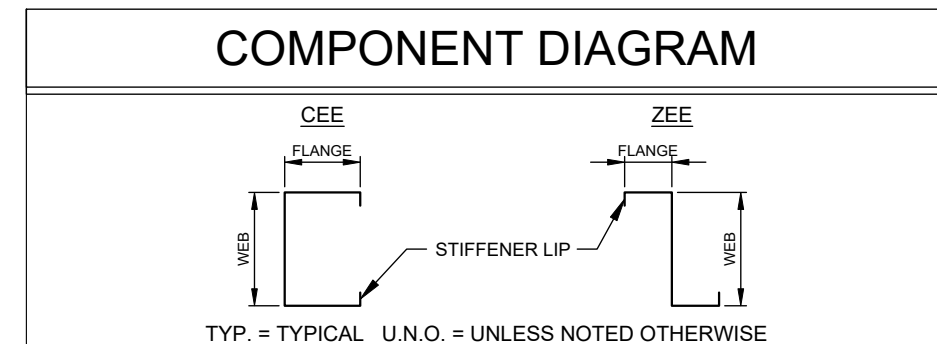

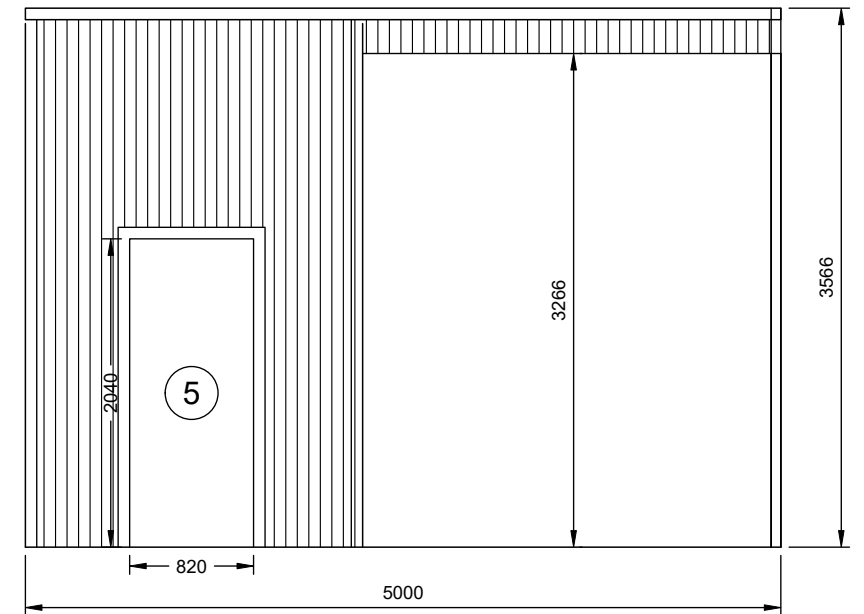
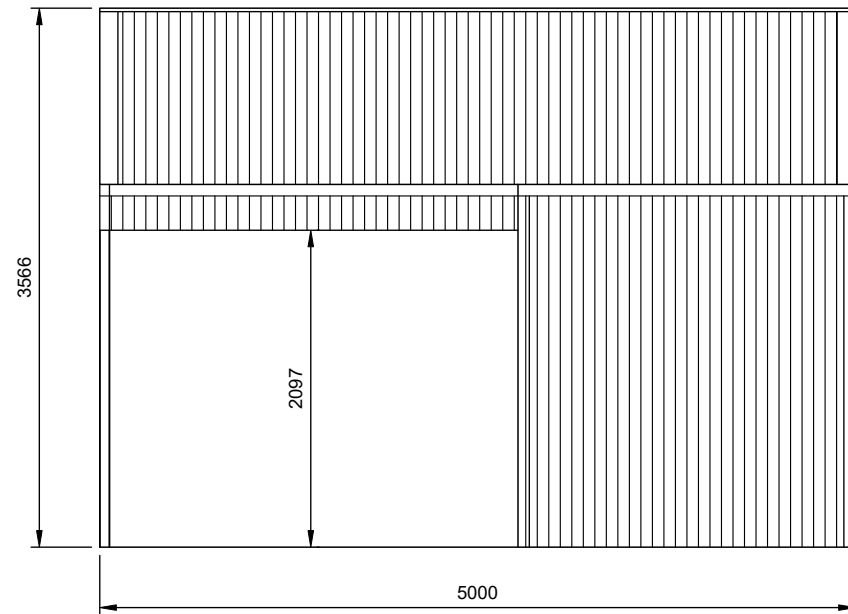

1 RIGHT ELEVATION  
2 SCALE: 1:50

2 LEFT ELEVATION  
2 SCALE: 1:50

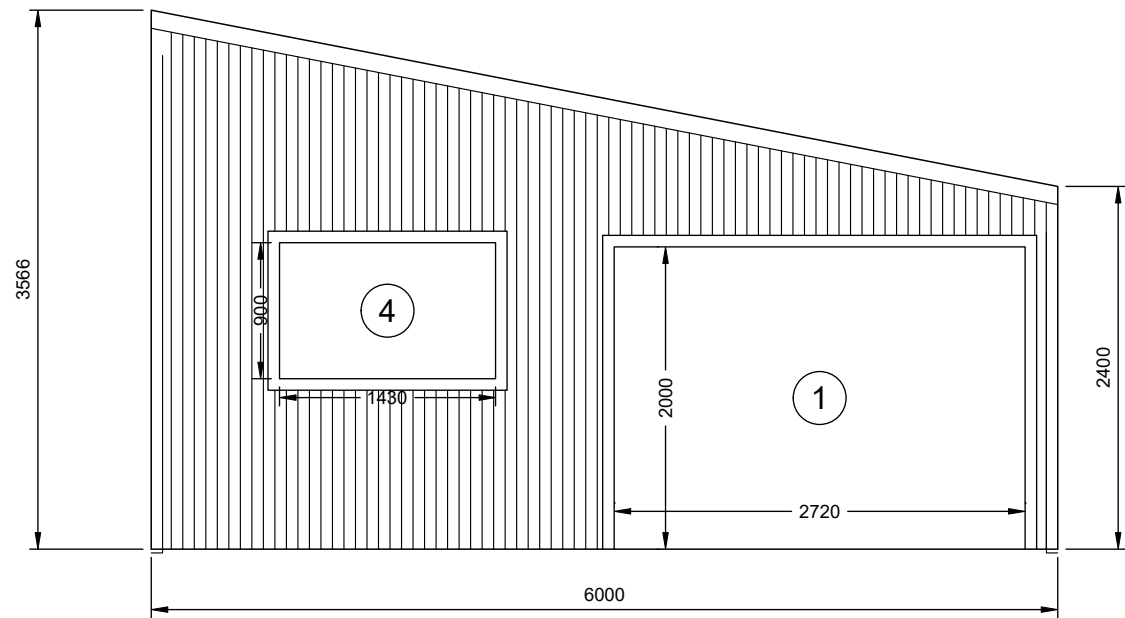

2 FRONT ELEVATION  
3 SCALE: 1:50

FRAME #2

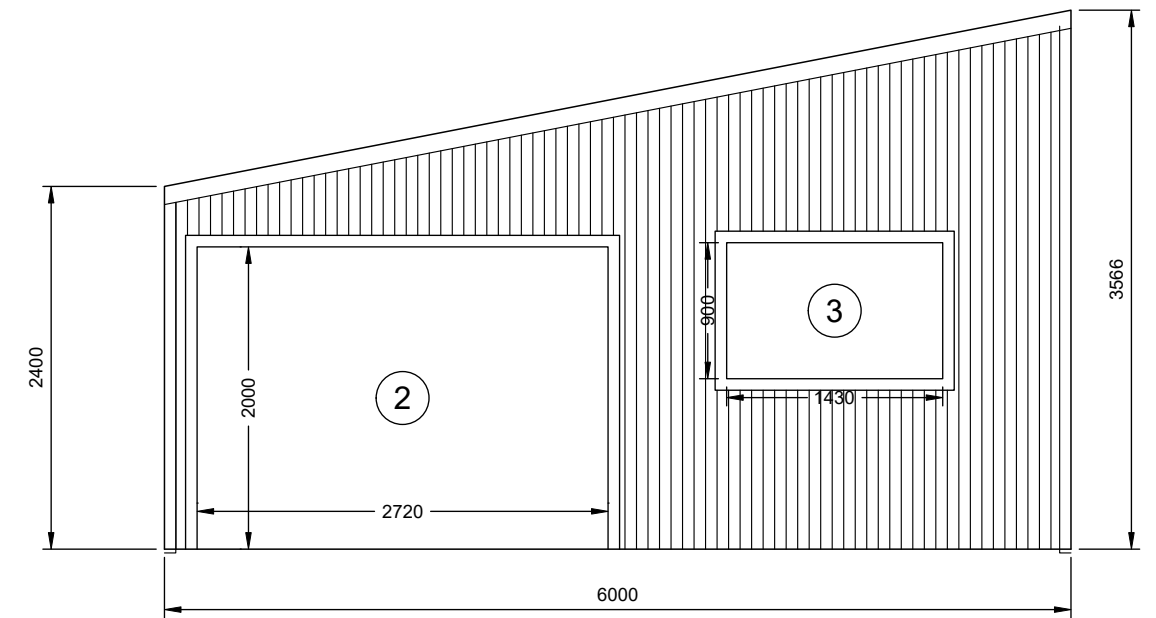

1 REAR ELEVATION  
3 SCALE: 1:50

FRAME #3

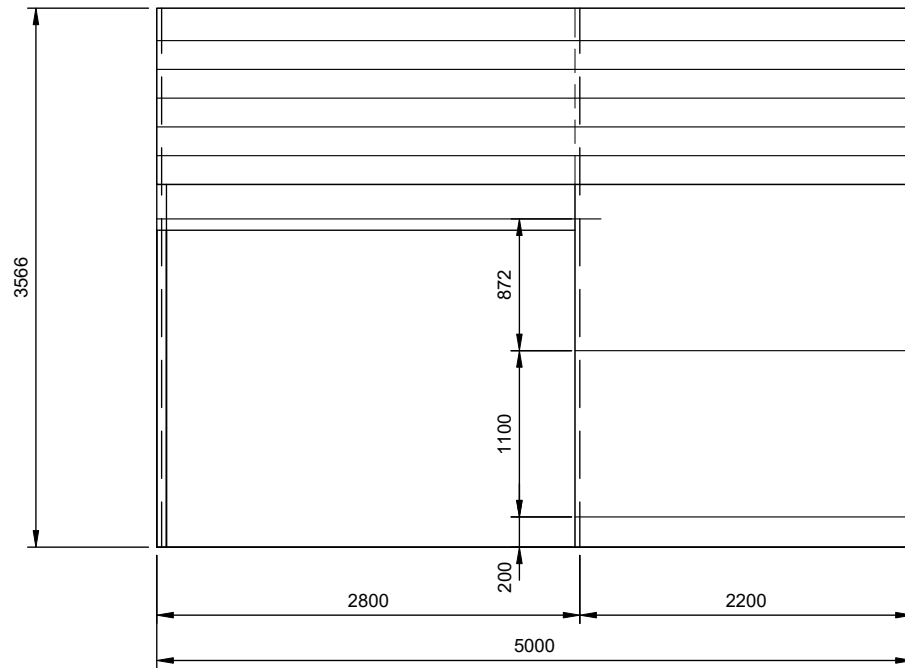

1 RIGHT ELEVATION  
4 SCALE: 1:50

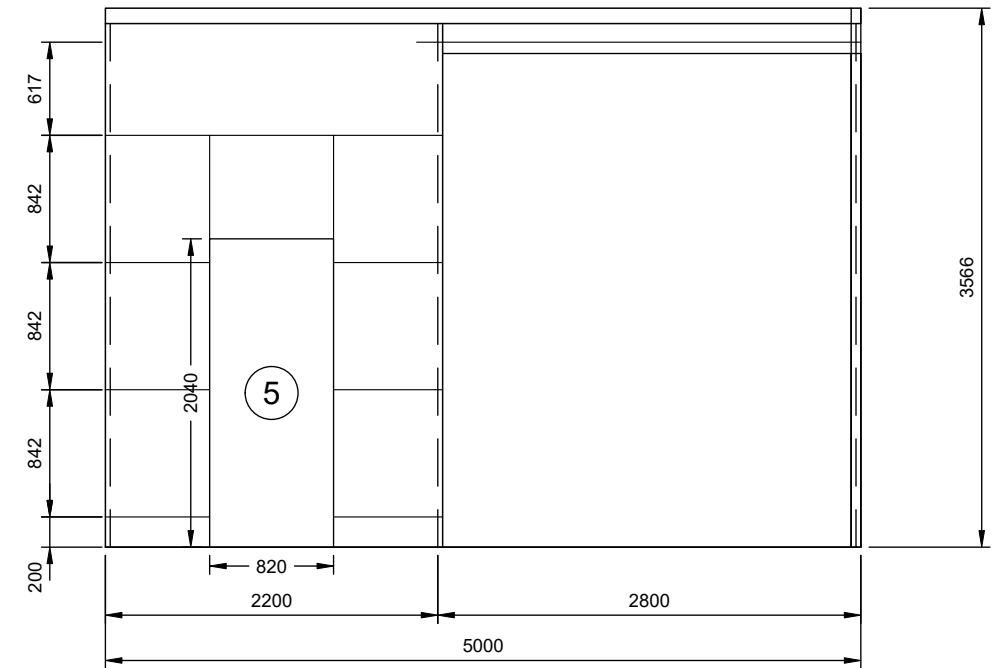

2 LEFT ELEVATION  
4 SCALE: 1:50

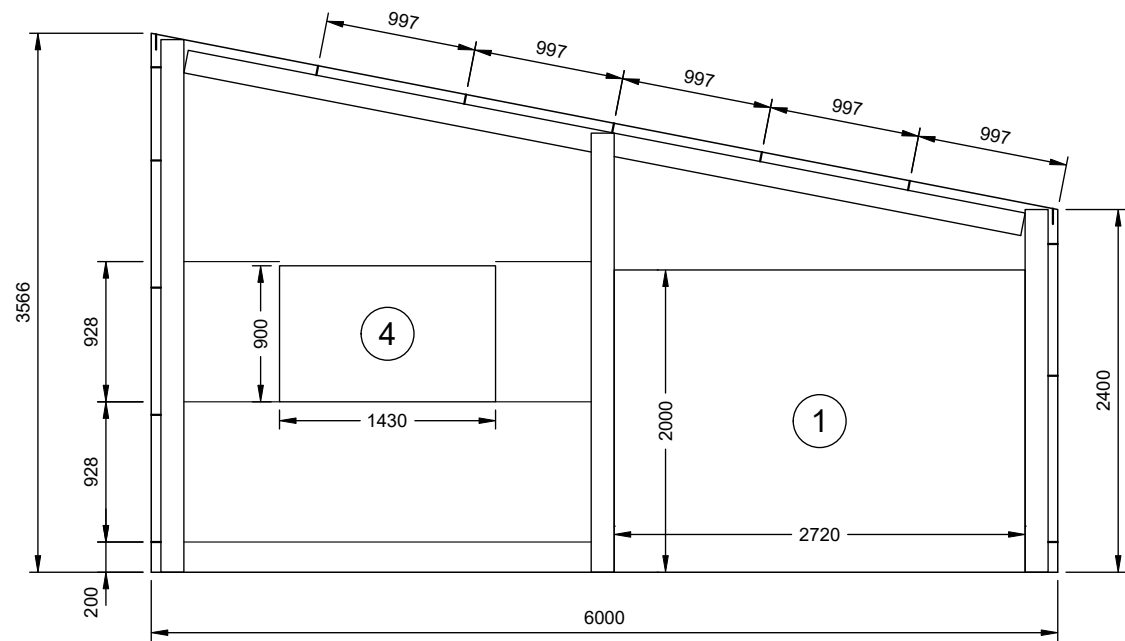

2 FRONT ELEVATION  
5

SCALE: 1:50

FRAME #2

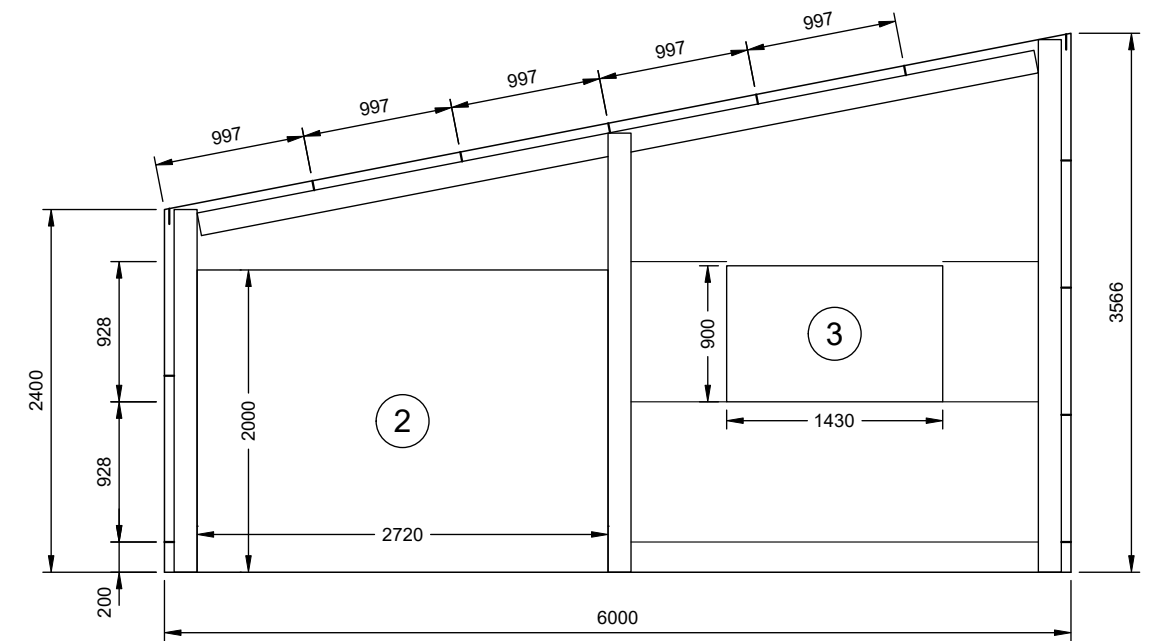

1 REAR ELEVATION  
5

SCALE: 1:50

FRAME #3

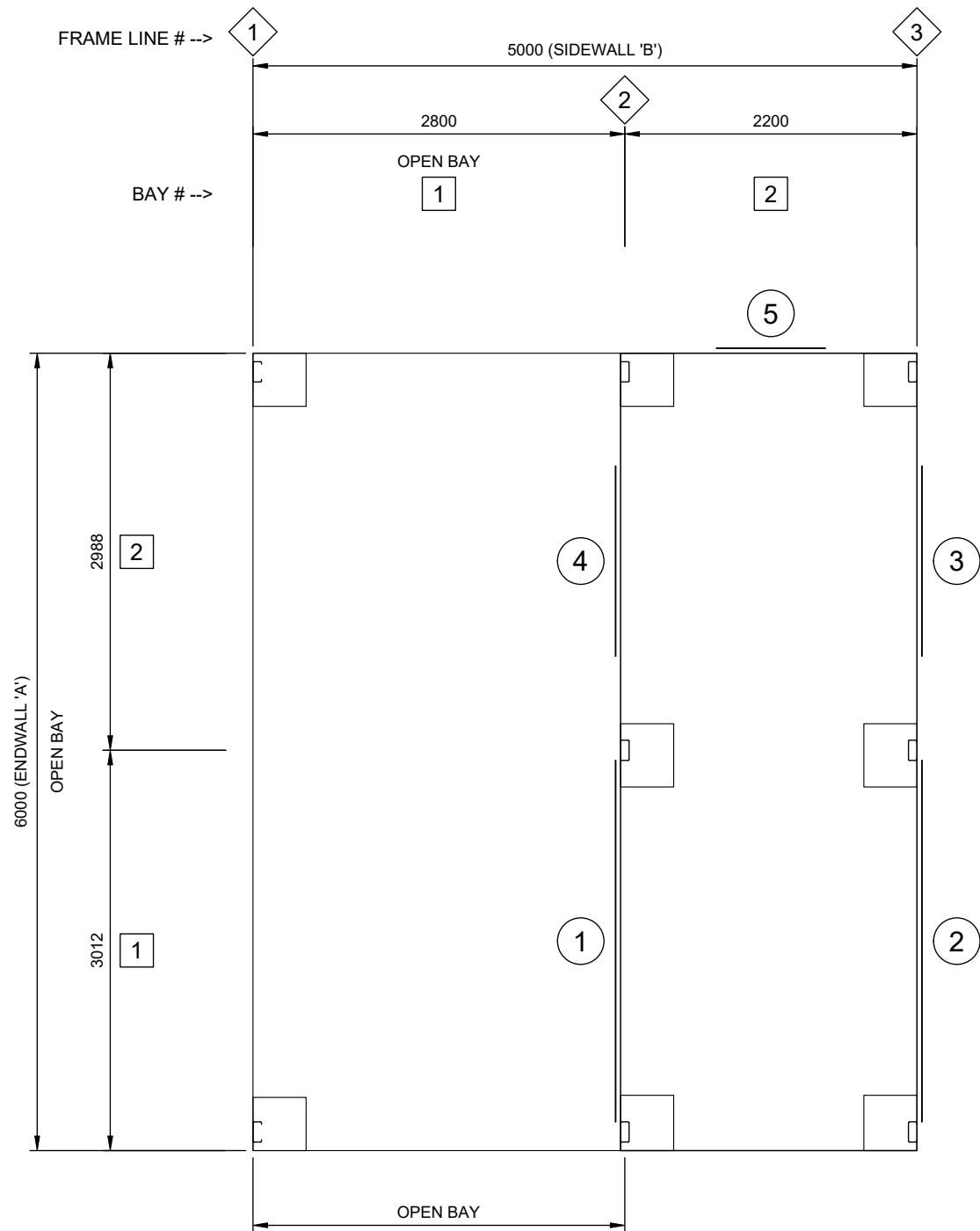

**1 FLOOR PLAN**  
**6** SCALE: 1:50

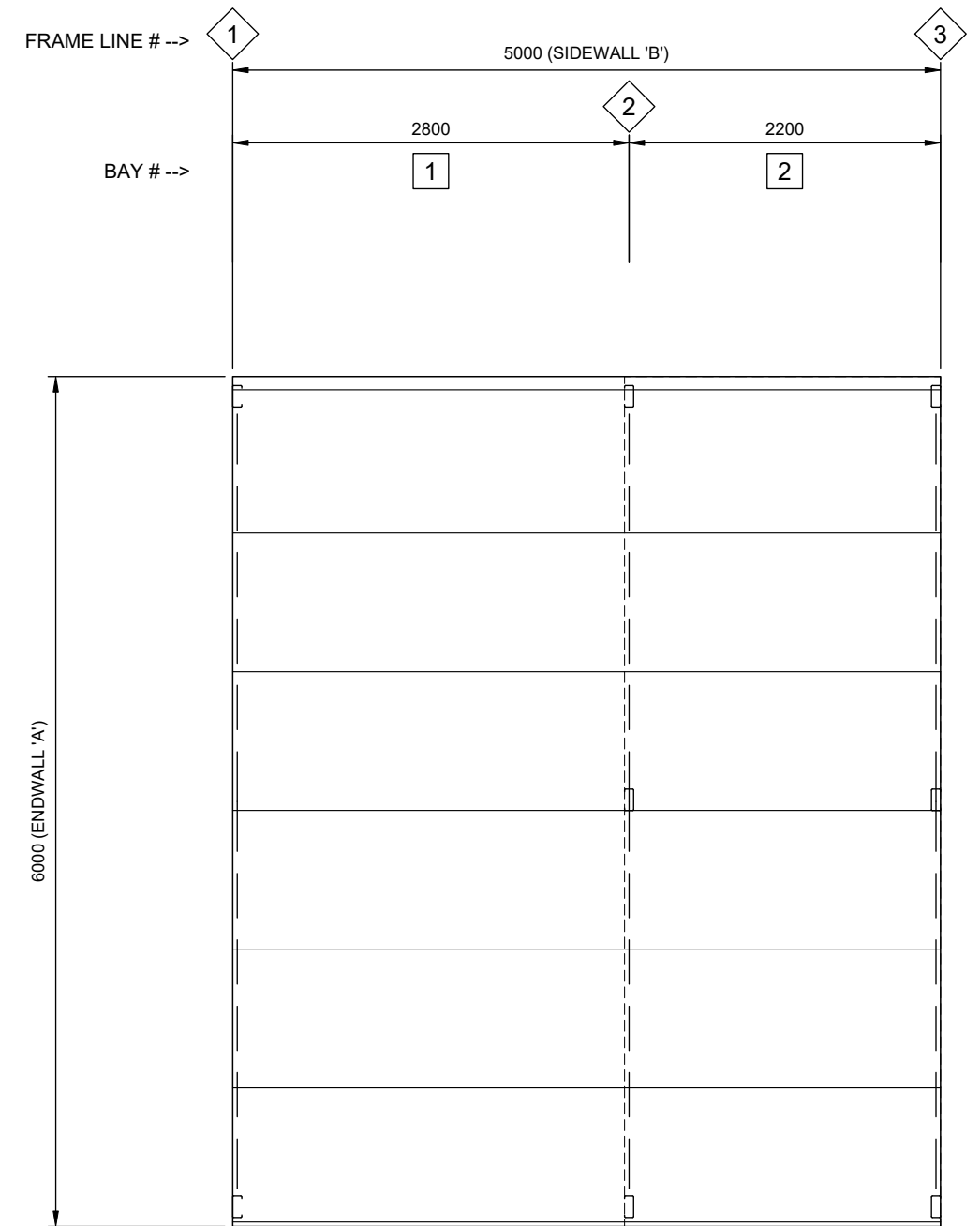

**2 ROOF FRAMING PLAN**  
**6** SCALE: 1:50

**SLAB FOUNDATIONS DOMESTIC / LIGHT INDUSTRIAL**  
(100mm MINIMUM CONCRETE SLAB INCLUDED)

SOIL CLASSIFICATION (COMPACTED)	REINFORCING IN SLAB	EDGE BEAM	PIER	EDGE BEAM (slab thickness not included)	
				DEPTH	WIDTH
A, S, & M	SL72	---	450 x 400	---	---
M - D	SL82	L11TM3	---	300	300
H TO H - D	SL82	L11TM3	---	400	300
E TO E - D	SL82	L11TM4	---	400	400
P (DROP EDGE BEAM OR STANDARD EDGE BEAM WITH PIERS UNDER COLUMNS 300 INTO FIRM GROUND)	SL82	L11TM4	450ø	400	400

**THICKNESS:** 100MM WITH MINIMUM 30MM COVER. REFER TO SLAB FOUNDATION TABLE FOR REINFORCING SPECIFICATION

**STRENGTH:** 25mPa

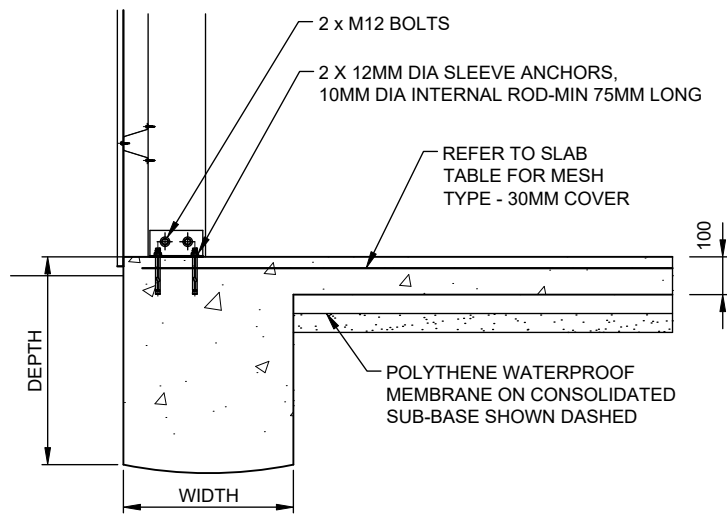

**Y** SLAB DETAIL

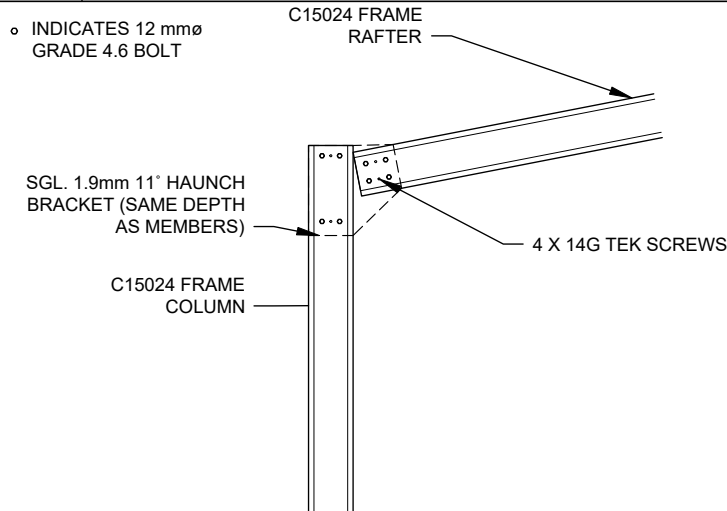

**A** HAUNCH CONNECTION

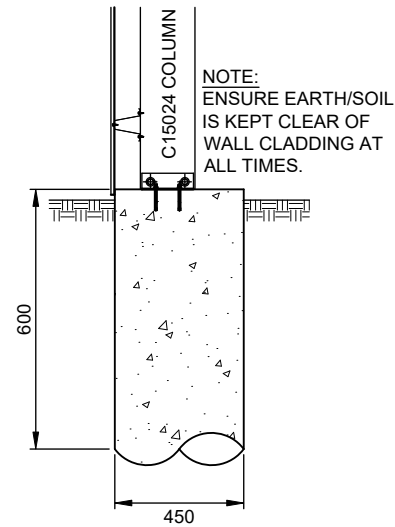

**Z** ALTERNATE PIER DETAIL

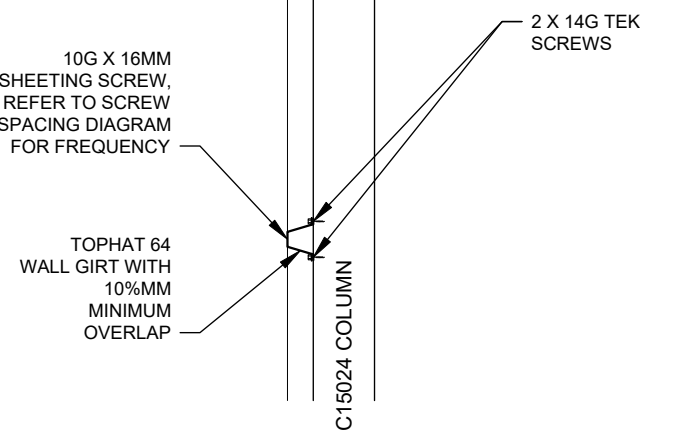

**F** GIRTS CONNECTION

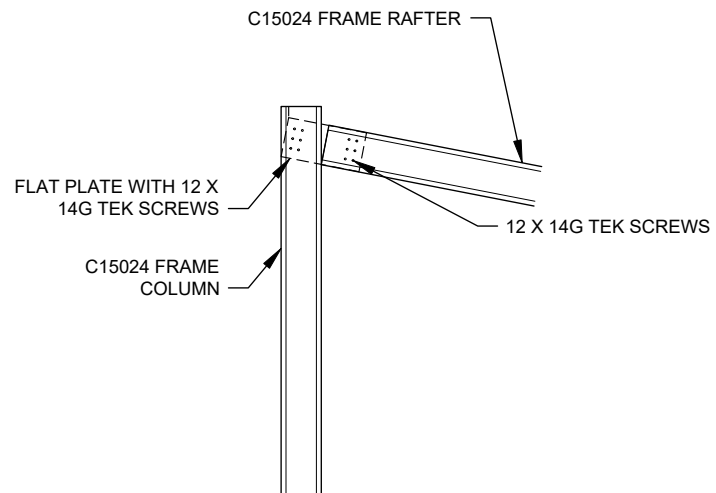

**B** HIGH EAVE HAUNCH CONNECTION

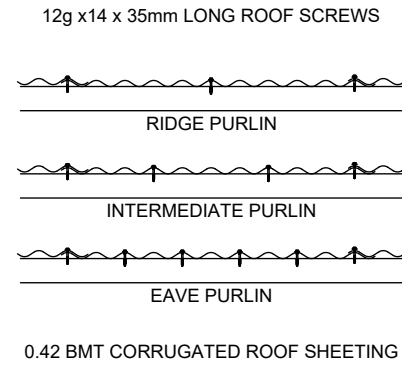

**H** ROOF SHEETING

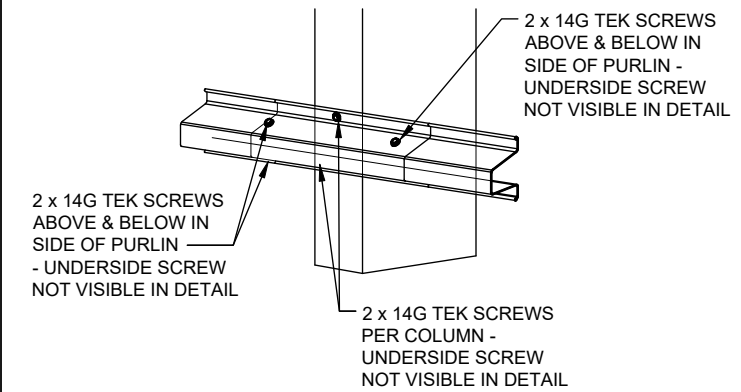

**F** TOP HAT CONNECTION

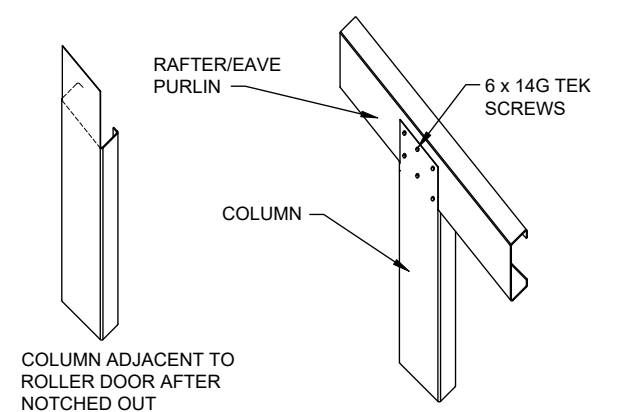

**D** ENDWALL MULLION ROTATED

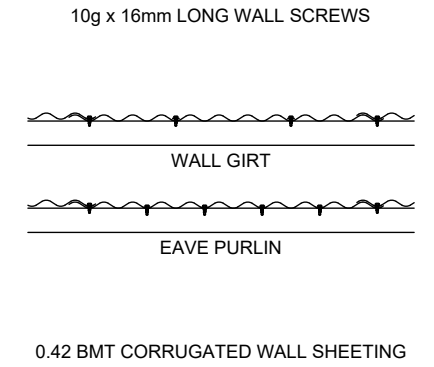

**I** WALL SHEETING

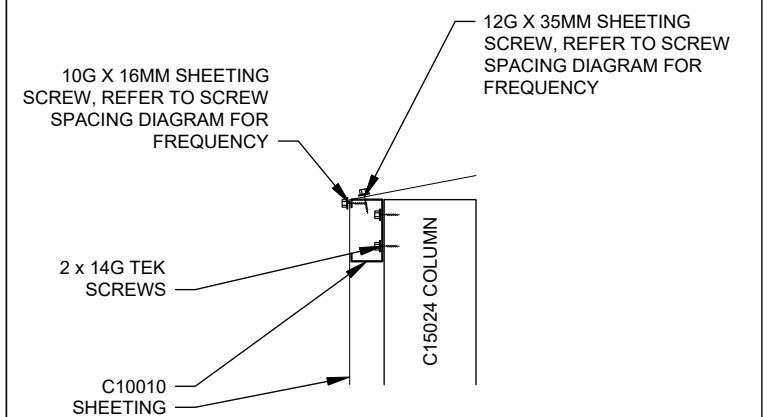

**G** EAVE CONNECTION

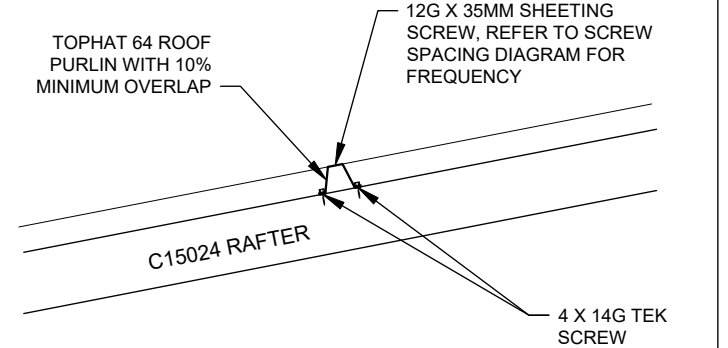

**E** PURLIN CONNECTION

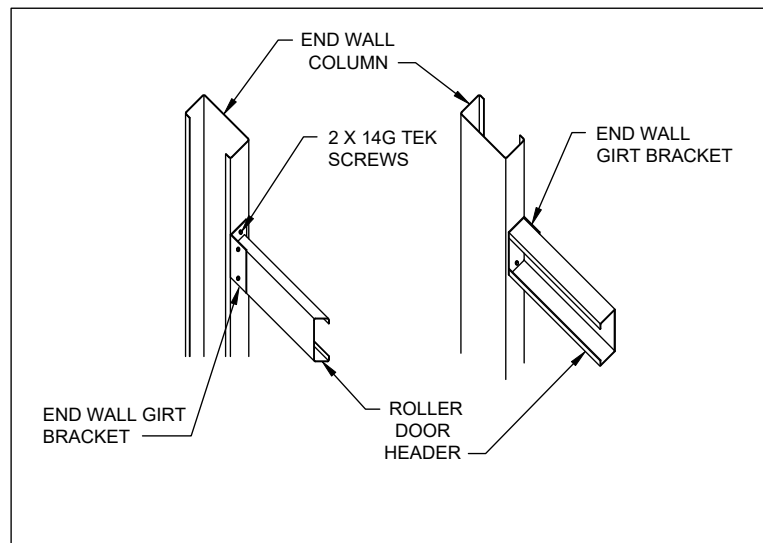

**N** END DOOR HEADER AND JAMB

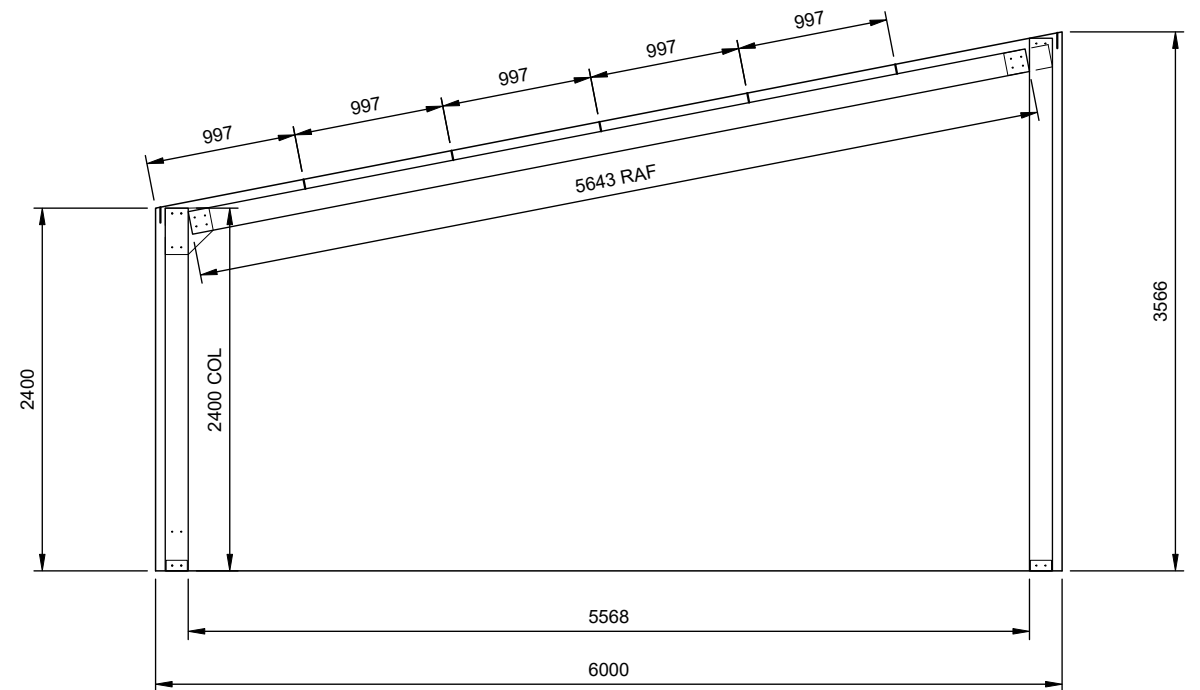

**1** ROOF ONLY FRAME CROSS-SECTION  
**8** SCALE: 1:50 FRAME 1

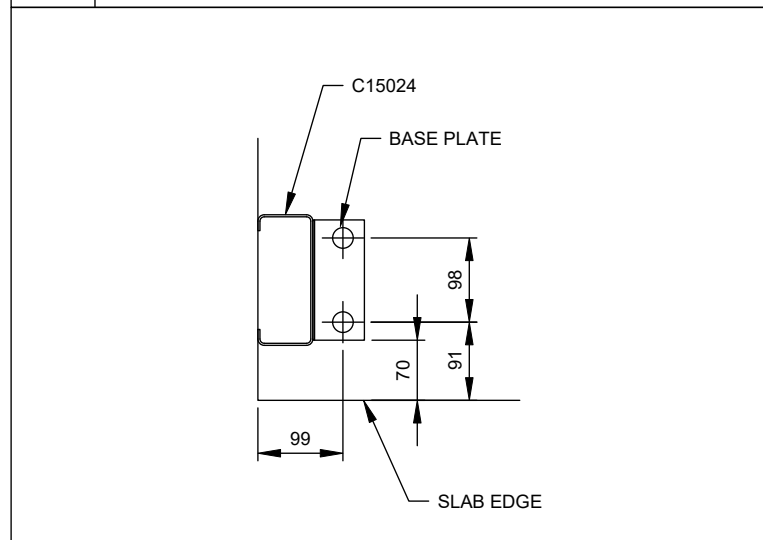

**J** CORNER COLUMN BASE

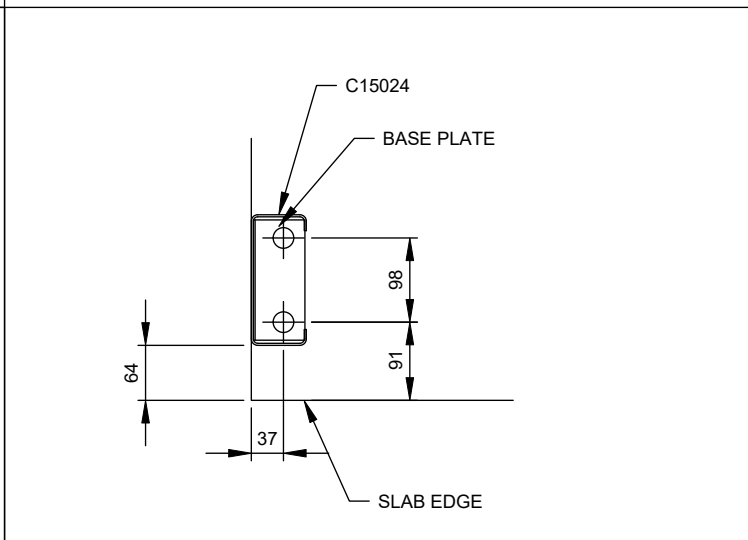

**K** ROOF ONLY COLUMN BASE

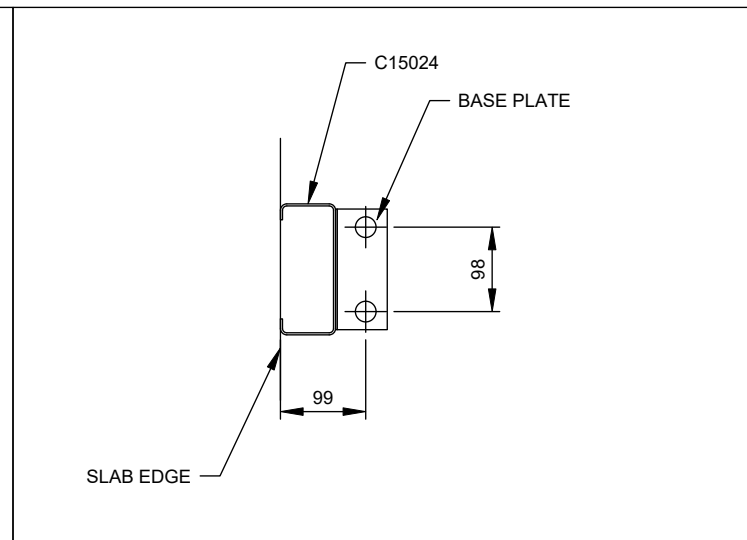

**L** ROTATED ENDWALL MULLION BASE

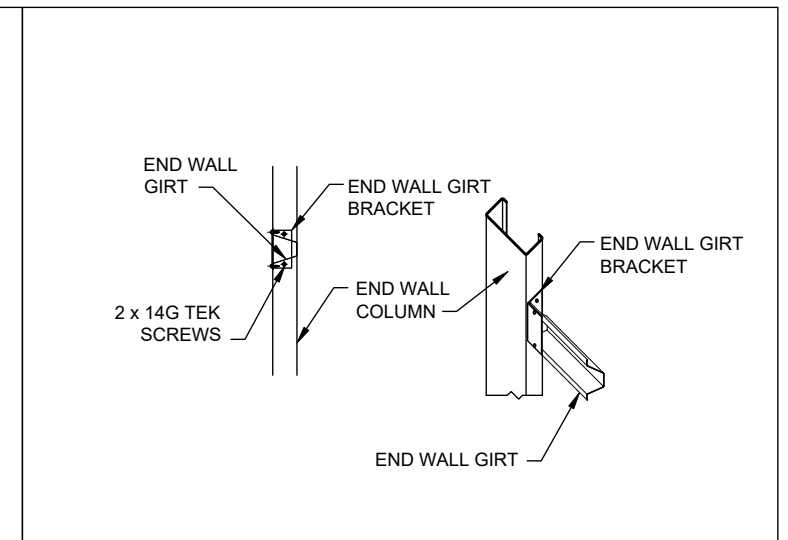

**M** ENDWALL GIRT BRACKET