



TITLE : FEATURE SURVEY	LOT : 20	SUBURB : LANDSDALE		DP : 427262
CLIENT : N/A	AUTHORITY : CITY OF WANNEROO		C/T : N/A	
BUILDER : URBAN WA CONSTRUCTION PTY LTD	UBD REF : 208 N 1	GPS : S 31.82003°	E 115.86987°	
 P: (08) 9354 8511 W: www.linkssurveying.com.au E: info@linkssurveying.com.au				
	SHEET 1 of 1	BUILDER'S REF	SURVEYED 20/06/24	SCALE @ A3 1:200
NOTE This PLAN is current at the Surveyed Date, NOT FOR CONSTRUCTION purposes without site corroboration. The cadastral boundary POSITION is APPROXIMATE & requires survey confirmation - Check Landgate Plan & Certificate of Title for Encumbrances including Easements, Caveats, Covenants etc. All SERVICES require verification from the relevant AUTHORITY - suggest contacting "Dial Before You Dig" for underground services & a site inspection. © STANDFAST NOMINEES 1996				

GROUND COVER
SANDY

SERVICE LEGEND

POWER	
CONSUMER POLE	○ CP
POWER POLE	○ PP
LIGHT POLE	○ LP
STAY POLE	○ SP
S. WIRE ANCHOR	○ SWA
UNI PILLAR	⊗
EXPOSED CABLES	○ EC
GAS	
PRE-LAID CONN.	○ GPL
METER	□ GM
SEWERAGE	
MANHOLE	○ SMH
INSPECT. SHAFT	○ IS
INSPECT. OPENING	○ IO
HOUSE CONNECTION	○ HC
HOUSE CONN. INDICATOR	○ HCI
INSPECT. SHAFT CONNECTION	○ ISC
TELE.	
PIT	□ TEL
PRE-LAID CONN.	○ TPL
DRAINAGE	
MANHOLE	○ DMH
GULLY PIT	▢
LOT PIT	○ LDP
HOUSE CONN.	○ DHC
SIDE ENTRY PIT	▢
COMBINATION ENTRY PIT	▢
WATER	
STOP VALVE	○ WSV
HYDRANT	○ HY
FLUSH POINT	○ FP
WATER TAP	⊗ WTP
WATER METER	⊕ M
PRE-LAID CONN.	○ WPL
SURVEY	
DATUM NAIL	◆
PEG FOUND	○ PF
PEG DISTURBED	○ PD
PEG GONE	PG
STAKE FOUND	○ STF

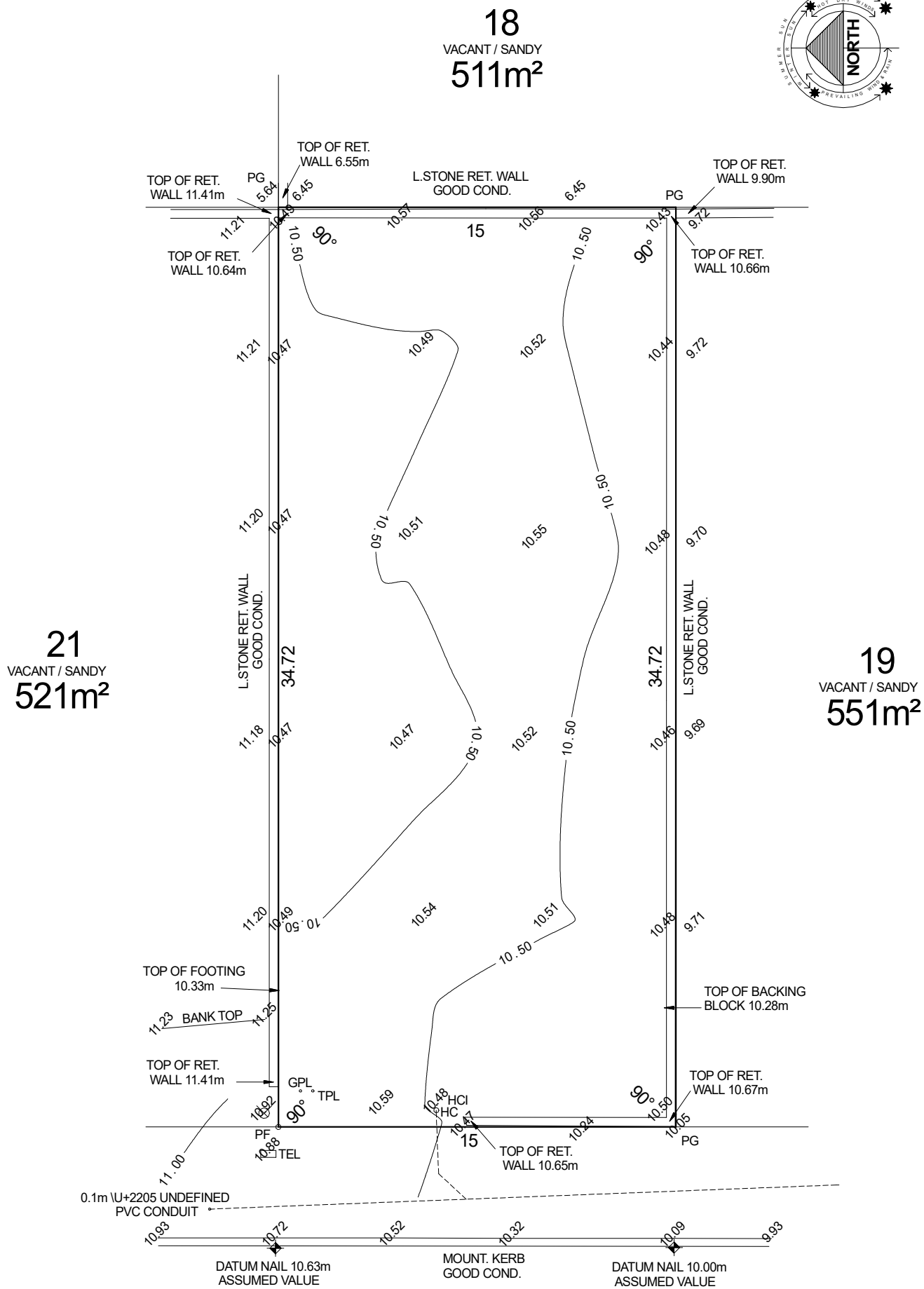

LOT RECORDS

STATUS	LOCATED	AVAILABLE	NO SERVICE	CONFIRM
WATER				✓
SEWERAGE	✓			
GAS	✓			
TELE.	✓			
DRAINAGE				✓
POWER U/G	✓			
O/H			✓	

AREA: NEW 11/2023
COASTAL DISTANCE >10km
LOT: 20
AREA: 521 m²78
APPROX. AHD +50.44m

SERVICES MARKED CONFIRM REQUIRE BUILDER / CLIENT TO CONFIRM POSITION & / OR AVAILABILITY ON SITE. APPROXIMATE AHD CONNECTION ONLY. HEIGHT RESTRICTIONS REQUIRE ACCURATE GEODETIC CONNECTION.

SEWER CONNECTION POSITION APPROXIMATE ONLY
SEWER INVERT LEVEL 8.82
SEWER BROUGHT UP 0.70
DEPTH TO CONNECTION 0.96

ENCORE RISE
BITUMEN



URBAN WA
LOT 20 ENCORE RISE
LANDSDALE
CITY OF WANNEROO

JOB NUMBER 2024116	DRAWING NAME EXISTING SITE PLAN		
START DATE JULY 2024	REVISION DESCRIPTION	IN.	DATE
SHEET 01 of 11	PLANNING DRAWINGS	LLV	17/07/24
SCALE 1:200	REVISION A	LJ	25/07/24
	WORKING DRAWINGS	TR	30/07/24
	PRESTART	JH	17/09/24
	PLANNING COMMENTS	LJ	17/10/24

KTR CREATIONS
IMAGINE | CREATE | CONSTRUCT
BUILDING DESIGN AND DRAFTING
www.ktrcreations.com.au
design@ktrcreations.com.au
9381 2106
1 Carbonate Road,
Wangara, WA 6065

CONSTRUCTION NOTE:
All drawings to be reviewed and checked by the Builder, Client, Sub-Contractors or the like before commencement of any works. No responsibility will be accepted by KTR Creations if no correspondence was coordinated prior or during construction.

COPYRIGHT:
This plan shall remain the sole property of KTR Creations and must not be given, or resold and must not be reproduced or copied without the permission in writing by KTR Creations

NOTE:
BUILDER TO COMPLETE SITE INSPECTION TO DETERMINE EXISTING RETAINING BOTTOM OF WALL DEPTH TO ENSURE NEW STRUCTURES WILL NOT UNDERMINE

NOTE:
BUILDER TO LIAISE WITH WESTERN POWER REGARDING OVERHEAD CONSUMER LINES, POWER DOMES AND DISTRIBUTION BOARDS. ALL PROVISIONS AND LOCATIONS TO WESTERN POWERS DISCRETION.

NOTE:
BUILDER TO LIAISE WITH WATER CORPORATION REGARDING WATER METERS. ALL PROVISIONS AND LOCATIONS TO WATER CORPORATION'S DISCRETION.

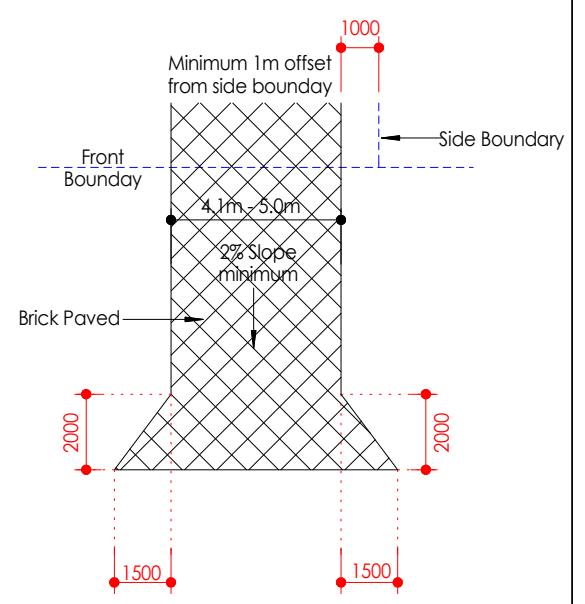

BRICKPAVED CROSSING
Scale 1:200

18
VACANT / SANDY
511m²

21
VACANT / SANDY
521m²

19
VACANT / SANDY
551m²

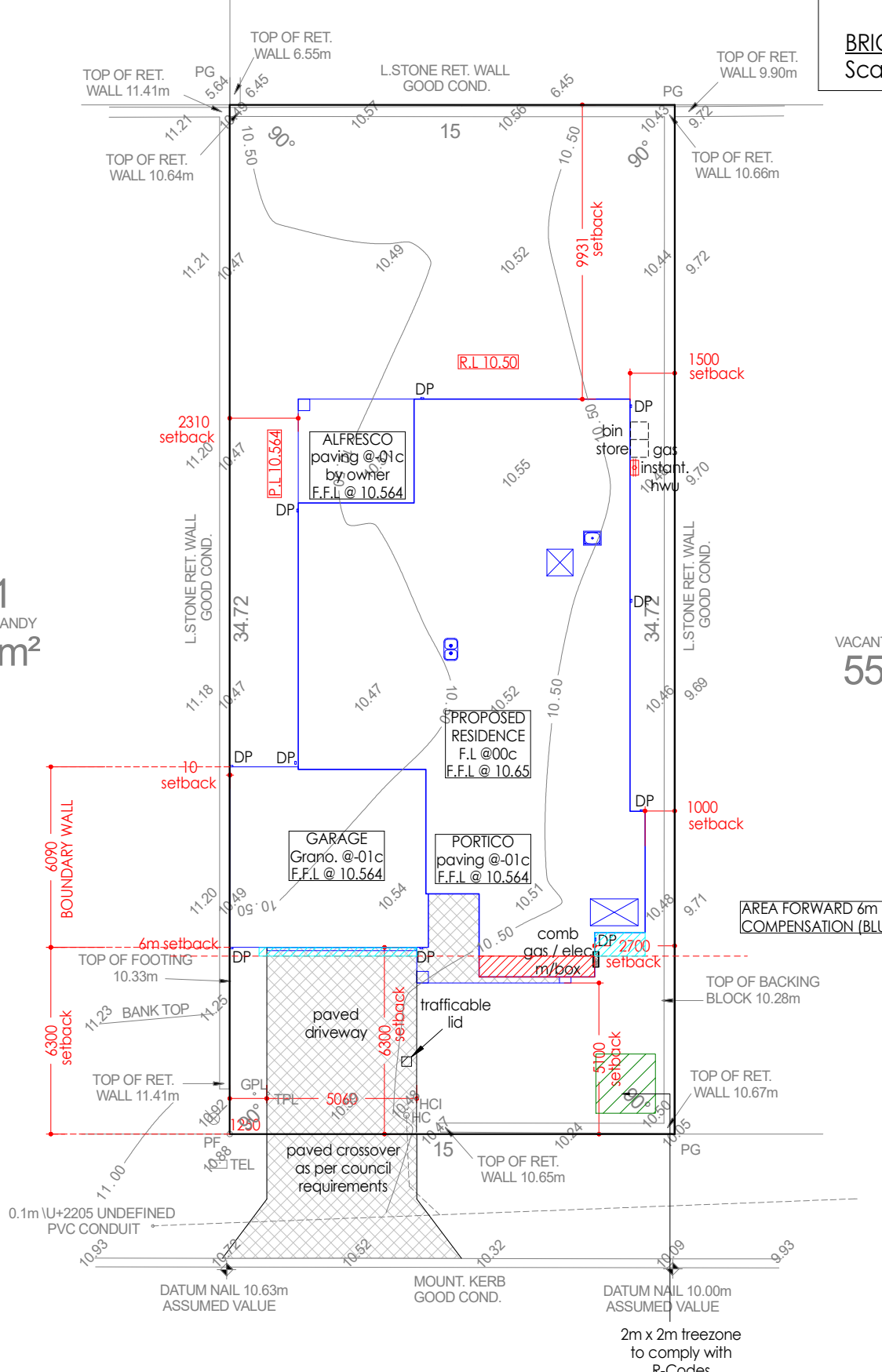

ENCORE RISE
BITUMEN



URBAN WA
LOT 20 ENCORE RISE
LANDSDALE
CITY OF WANNEROO

JOB NUMBER 2024116		DRAWING NAME PROPOSED SITE PLAN	
START DATE JULY 2024	REVISION DESCRIPTION	IN.	DATE
SHEET 02 of 11	PLANNING DRAWINGS	LLV	17/07/24
	REVISION A	LJ	25/07/24
SCALE 1:200	WORKING DRAWINGS	TR	30/07/24
	PRESTART	JH	17/09/24
A3	REVISION A		

KTR CREATIONS
IMAGINE | CREATE | CONSTRUCT
BUILDING DESIGN AND DRAFTING
www.ktrcreations.com.au
design@ktrcreations.com.au
9381 2106
1 Carbonate Road,
Wangara, WA 6065

CONSTRUCTION NOTE:
All drawings to be reviewed and checked by the Builder, Client, Sub-Contractors or the like before commencement of any works. No responsibility will be accepted by KTR Creations if no correspondence was coordinated prior or during construction.

COPYRIGHT:
This plan shall remain the sole property of KTR Creations and must not be given, or resold and must not be reproduced or copied without the permission in writing by KTR Creations

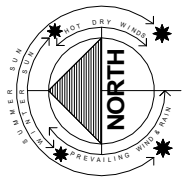

NOTE:
LOCATION AND SIZE OF DOWNPIPES AND SOAKWELLS ARE INDICATIVE ONLY & MAY BE CHANGED ON SITE TO A PLUMBERS DISCRETION

DRAINAGE CALCULATIONS:
NEW ROOF AREA TO DWELLING = $226.5 \times 0.0125 = 2.83\text{m}^2$
No. OF NEW DOWN PIPES SERVING NEW ROOF AREA = 10
EACH DP SERVED VOLUME (ON AVG.) = 0.283m^3

DIAMETER	DEPTH	VOLUME	DP SERVED	TOTAL VOLUME
1200	1200	1.36m ³	4	1.132m ³
1200	1500	1.70m ³	6	1.698m ³

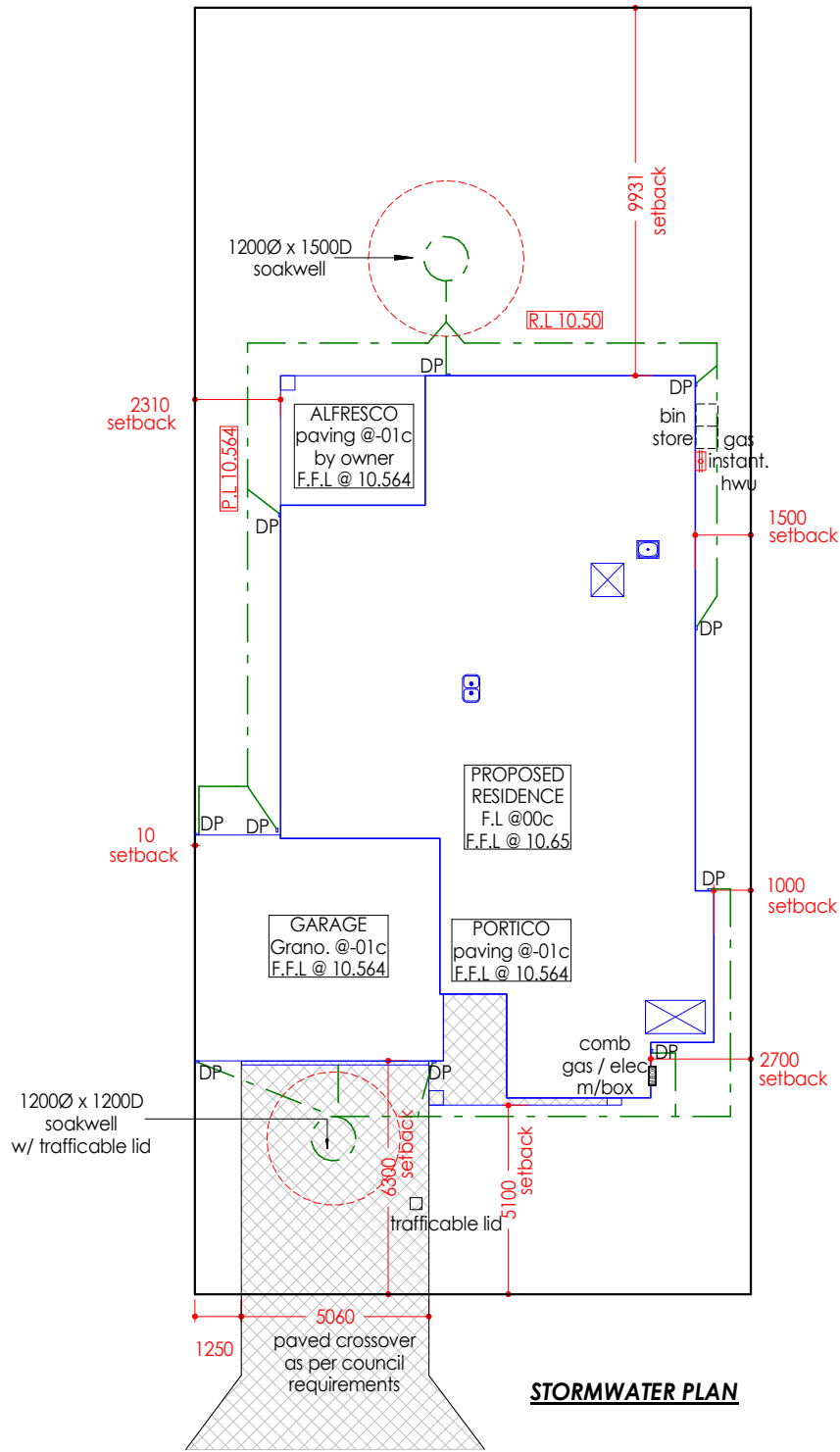

STORMWATER PLAN

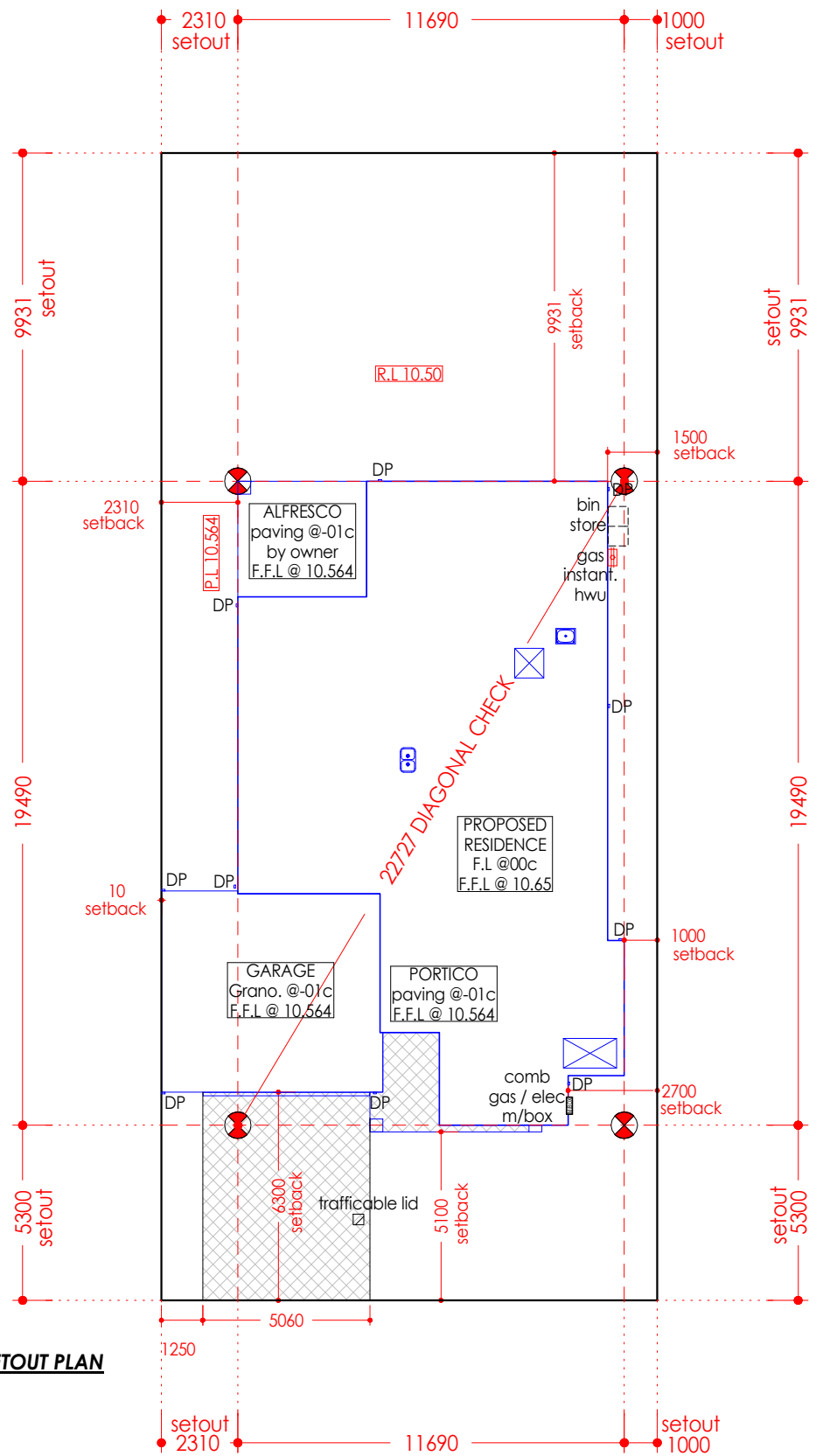

SETOUT PLAN



URBAN WA

LOT 20 ENCORE RISE
LANDSDALE
CITY OF WANNEROO



JOB NUMBER 2024116	
START DATE JULY 2024	
SHEET 03 of 11	A3
SCALE 1:200	REVISION -

DRAWING NAME STORMWATER-SETOUT PLAN		
REVISION DESCRIPTION	IN.	DATE
CONCEPT DESIGN	LJ	11/07/24
PLANNING DRAWINGS	LLV	17/07/24
REVISION A	LJ	25/07/24
WORKING DRAWINGS	TR	30/07/24
PRESTART	JH	17/09/24

KTR CREATIONS
IMAGINE | CREATE | CONSTRUCT
BUILDING DESIGN AND DRAFTING
www.ktrcreations.com.au
design@ktrcreations.com.au
9381 2106
1 Carbonate Road,
Wangara, WA 6065

CONSTRUCTION NOTE:
All drawings to be reviewed and checked by the Builder, Client, Sub-Contractors or the like before commencement of any works. No responsibility will be accepted by KTR Creations if no correspondence was coordinated prior or during construction.
COPYRIGHT:
This plan shall remain the sole property of KTR Creations and must not be given, or resold and must not be reproduced or copied without the permission in writing by KTR Creations

2c FACE BRICKWORK
BASED ON 290 x 90 x 162mm
RENDER AND CLADDING
AS PER ELEVATIONS
 - USE ONE THIRD BONDING METHOD
 WITH STD CUTS WHERE APPLICABLE
 AND SQUINTS TO 45° EXT CORNERS

TILED ROOF
25°38' PITCH U.O.N

WIND CLASSIFICATION
 AS PER ENGINEER'S DETAILS

NOTE:
 - WEATHERDRAFT SEALS TO
 ALL EXTERNAL DOORS

NOTE:
 - INSULATION TO SUIT ENERGY
 EFFICIENCY REQUIREMENTS

AREAS	
HOUSE	169.55m ²
GARAGE	39.97m ²
PORCH	6.34m ²
ALFRESCO	13.65m ²
TOTAL AREA	225.03m²
OPEN SPACE CALCULATOR	
LOT AREA	521m ² R 20
OPEN SPACE REQUIRED	260.5m ² (50%)
PROPOSED SITE COVER	207.72m ² (39.87%)
OPEN SPACE PROVIDED	313.28m ² (60.13%)

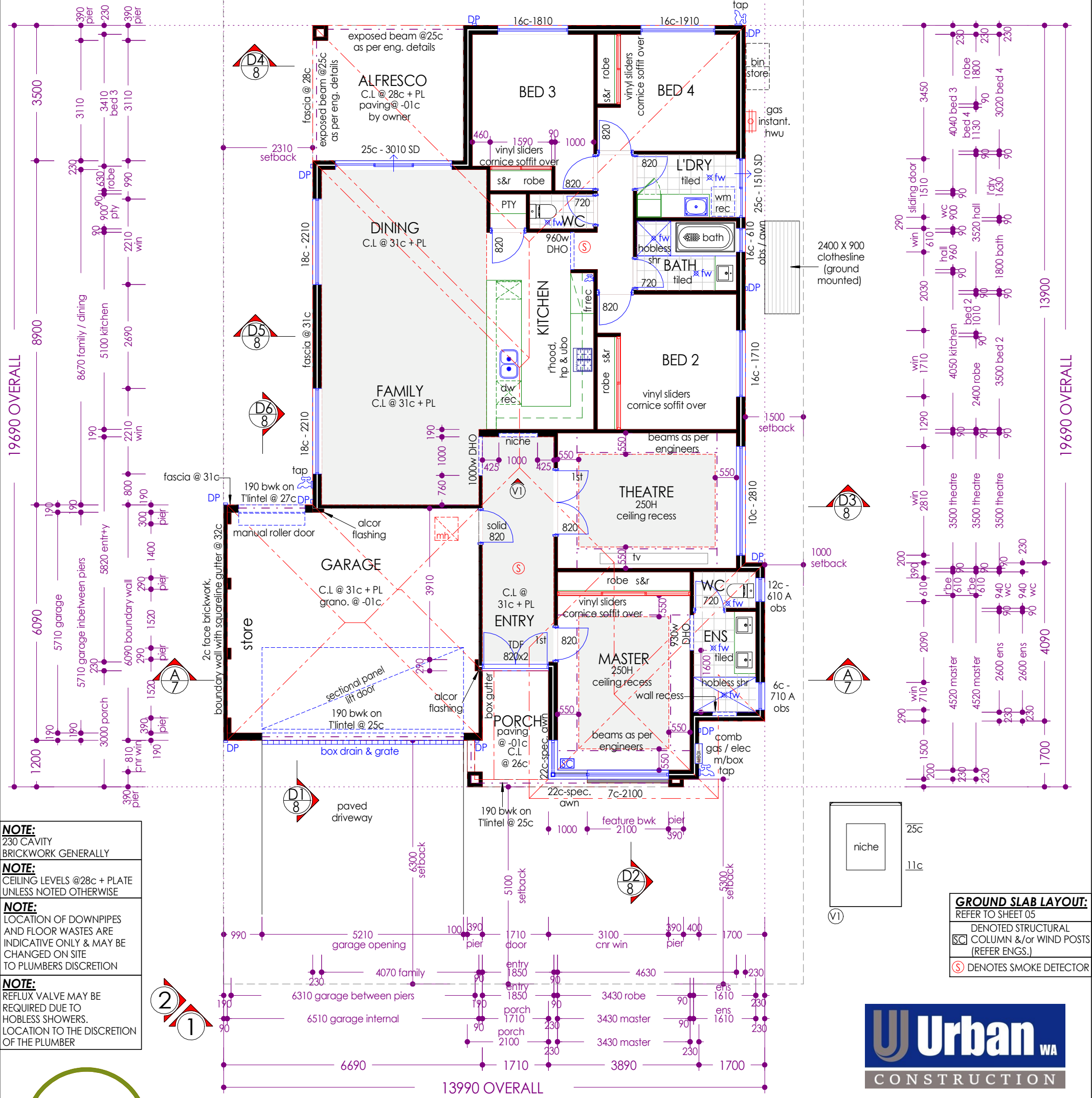
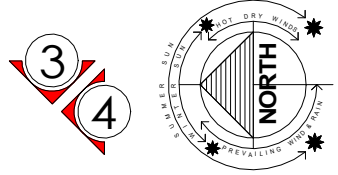

NOTE:
 230 CAVITY
 BRICKWORK GENERALLY

NOTE:
 CEILING LEVELS @28c + PLATE
 UNLESS NOTED OTHERWISE

NOTE:
 LOCATION OF DOWNPIPES
 AND FLOOR WASTES ARE
 INDICATIVE ONLY & MAY BE
 CHANGED ON SITE
 TO PLUMBERS DISCRETION

NOTE:
 REFLUX VALVE MAY BE
 REQUIRED DUE TO
 HOBLESS SHOWERS.
 LOCATION TO THE DISCRETION
 OF THE PLUMBER

GROUND SLAB LAYOUT:
 REFER TO SHEET 05

DENOTES STRUCTURAL COLUMN &/OR WIND POSTS (REFER ENGS.)
 DENOTES SMOKE DETECTOR



URBAN WA
 LOT 20 ENCORE RISE
 LANDSDALE
 CITY OF WANNEROO

JOB NUMBER		DRAWING NAME	
2024116		GROUND FLOOR PLAN	
START DATE	JULY 2024	REVISION DESCRIPTION	IN. DATE
SHEET	04 of 11	PLANNING DRAWINGS	LLV 17/07/24
SCALE	1:100	REVISION A	LJ 25/07/24
		WORKING DRAWINGS	TR 30/07/24
		PRESTART	JH 19/09/24
		PLANNING COMMENTS	LJ 17/10/24

KTR CREATIONS
 IMAGINE | CREATE | CONSTRUCT

BUILDING DESIGN AND DRAFTING
 www.ktrcreations.com.au
 design@ktrcreations.com.au
 9381 2106

1 Carbonate Road
 Wangara WA 6065

CONSTRUCTION NOTE:
 All drawings to be reviewed and checked by the Builder, Client, Sub-Contractors or the like before commencement of any works. No responsibility will be accepted by KTR Creations if no correspondence was coordinated prior or during construction.

COPYRIGHT:
 This plan shall remain the sole property of KTR Creations and must not be given, or resold and must not be reproduced or copied without the permission in writing by KTR Creations

NOTE:
REFLUX VALVE MAY BE
REQUIRED DUE TO
HOBLESS SHOWERS.
LOCATION TO THE DISCRETION
OF THE PLUMBER

LEGEND

— GROUND SLAB
- - - GROUND LEVEL
- - - BRICKWORK

NOTE:
* TO BE READ IN CONJUNCTION
WITH ENGINEERS DRAWINGS
* 230 EXTERNAL BWK (GENERALLY)

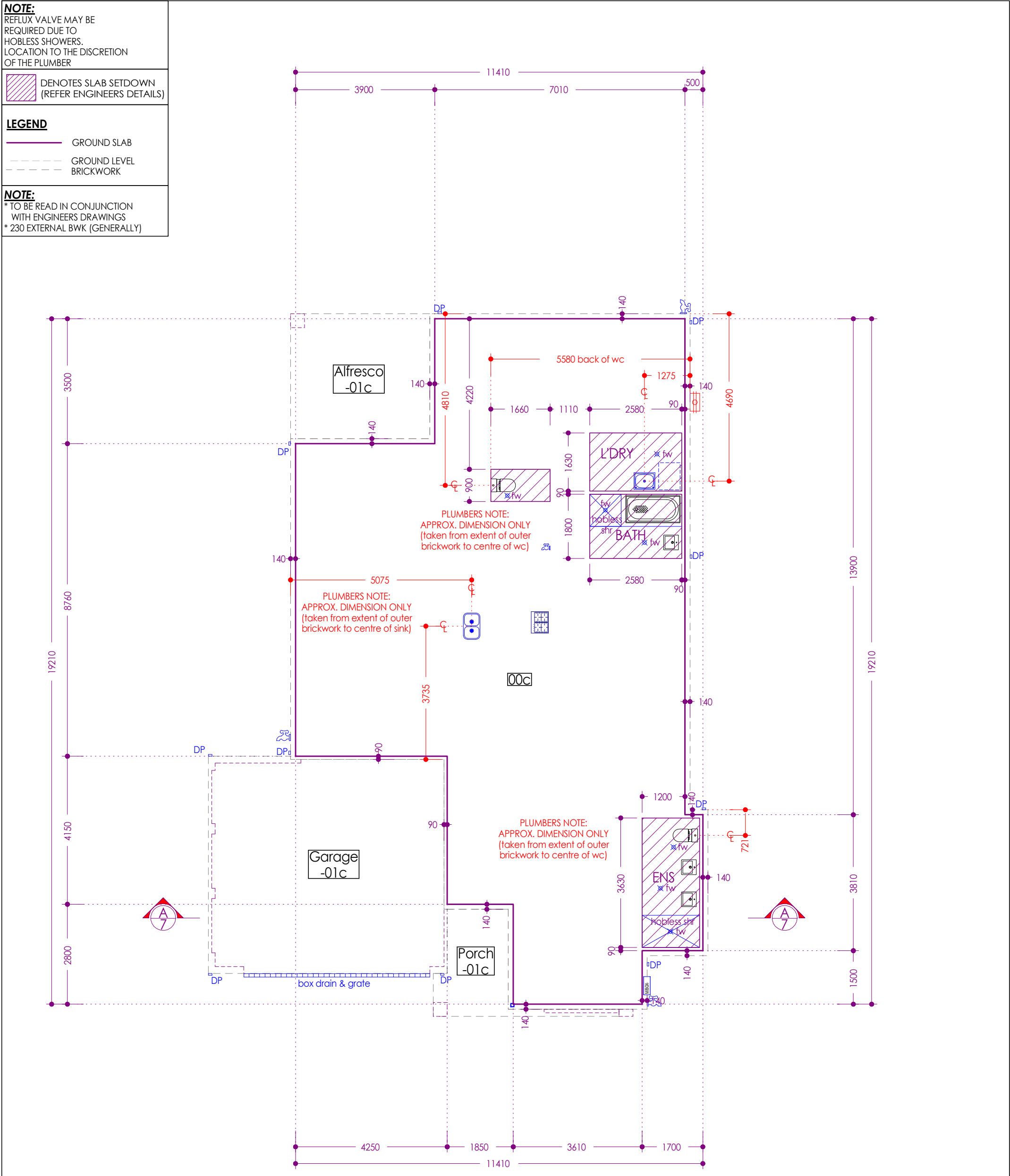

URBAN WA
LOT 20 ENCORE RISE
LANDSDALE
CITY OF WANNEROO

JOB NUMBER 2024116		DRAWING NAME GROUND SLAB LAYOUT		KTR CREATIONS IMAGINE CREATE CONSTRUCT	
START DATE JULY 2024	SHEET 05 of 11	REVISION A3	REVISION DESCRIPTION	IN.	DATE
PLANNING DRAWINGS			LLV	17/07/24	
WORKING DRAWINGS	LJ	25/07/24	PRESTART	JH	19/09/24
PLANNING COMMENTS	LJ	17/10/24	BUILDING DESIGN AND DRAFTING www.ktrcreations.com.au design@ktrcreations.com.au 9381 2106		
SCALE 1:100			1 Carbonate Road Wangara WA 6065		

CONSTRUCTION NOTE:
All drawings to be reviewed and checked by the Builder, Client, Sub-Contractors or the like before commencement of any works. No responsibility will be accepted by KTR Creations if no correspondence was coordinated prior or during construction.

COPYRIGHT:
This plan shall remain the sole property of KTR Creations and must not be given, or resold and must not be reproduced or copied without the permission in writing by KTR Creations

**2c FACE BRICKWORK
BASED ON 290 x 90 x 162mm
RENDER AND CLADDING
AS PER ELEVATIONS**
- USE ONE THIRD BONDING METHOD
WITH STD CUTS WHERE APPLICABLE
AND SQUINTS TO 45° EXT CORNERS

* HEAD FLASHING TO WINDOWS
IN ACCORDANCE WITH AS4773.2

**TILED ROOF
25°38' PITCH U.O.N**

WIND CLASSIFICATION
AS PER ENGINEER'S DETAILS

NOTE:
LDP not available at time of
planning drawings.

NOTE:
Planning may be required due
to special control area.

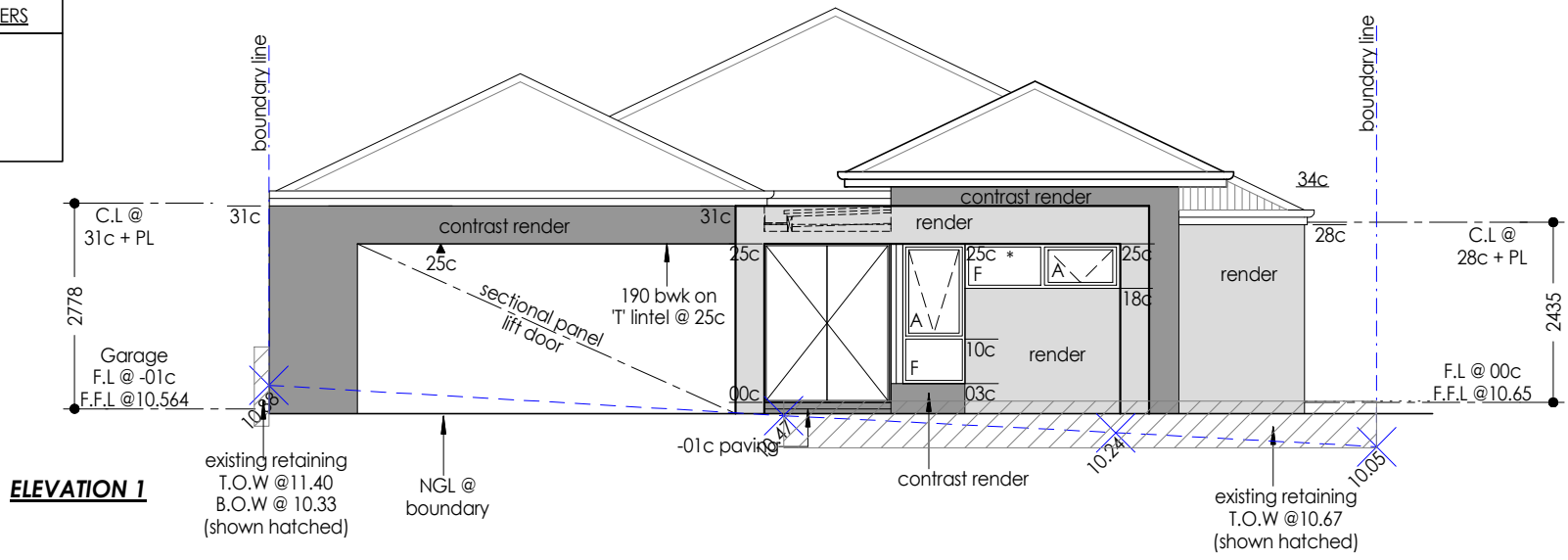

ELEVATION 1

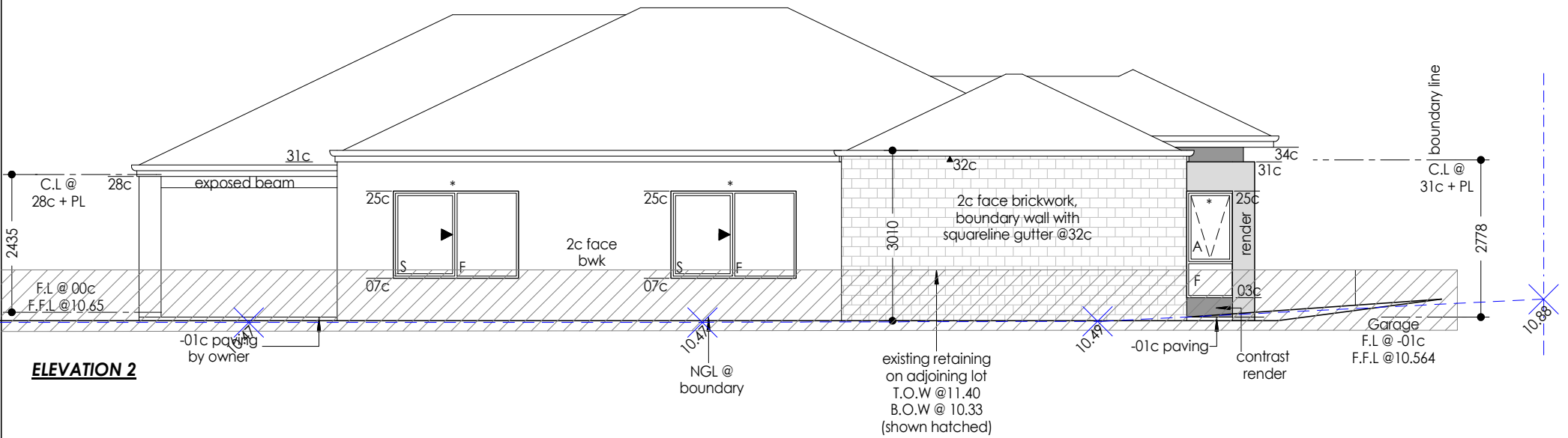

ELEVATION 2

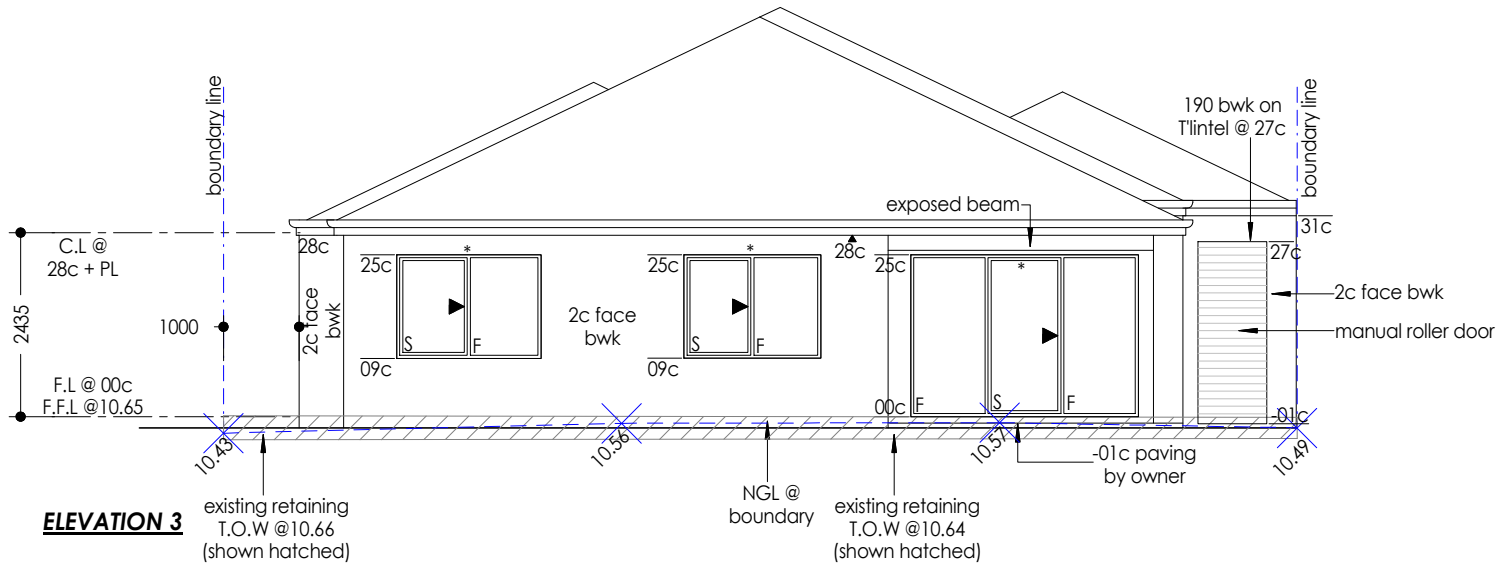

ELEVATION 3

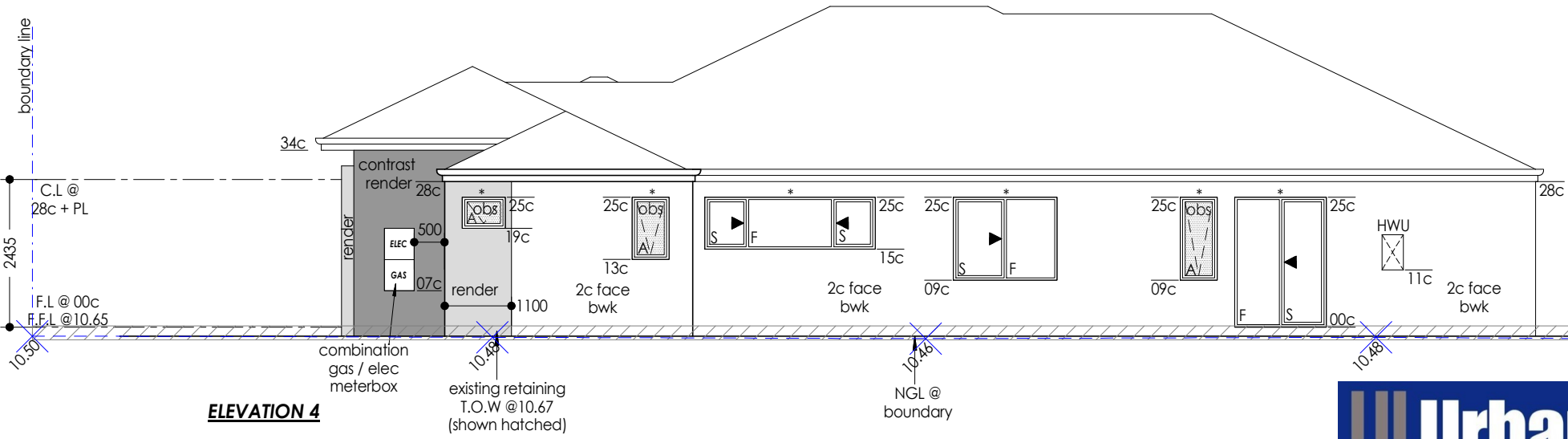

ELEVATION 4



URBAN WA
LOT 20 ENCORE RISE
LANDSDALE
CITY OF WANNEROO

JOB NUMBER 2024116		DRAWING NAME ELEVATIONS		KTR CREATIONS IMAGINE CREATE CONSTRUCT		CONSTRUCTION NOTE: All drawings to be reviewed and checked by the Builder, Client, Sub-Contractors or the like before commencement of any works. <u>No</u> responsibility will be accepted by KTR Creations if no correspondence was coordinated prior or during construction. COPYRIGHT: This plan shall remain the sole property of KTR Creations and must not be given, or resold and must not be reproduced or copied without the permission in writing by KTR Creations
START DATE JULY 2024		REVISION DESCRIPTION	IN.	DATE	BUILDING DESIGN AND DRAFTING www.ktrcreations.com.au design@ktrcreations.com.au 9381 2106	
SHEET 06 of 11	A3	PLANNING DRAWINGS	LLV	17/07/24	1 Carbonate Road Wangara WA 6065	
SCALE 1:100	REVISION A	REVISION A	LJ	25/07/24		
		WORKING DRAWINGS	TR	30/07/24		
		PRESTART	JH	19/09/24		
		PLANNING COMMENTS	LJ	17/10/24		

NOTE:
This typical wall detail applies to **ALL** boundary wall locations as per NCC 3.7.1.3

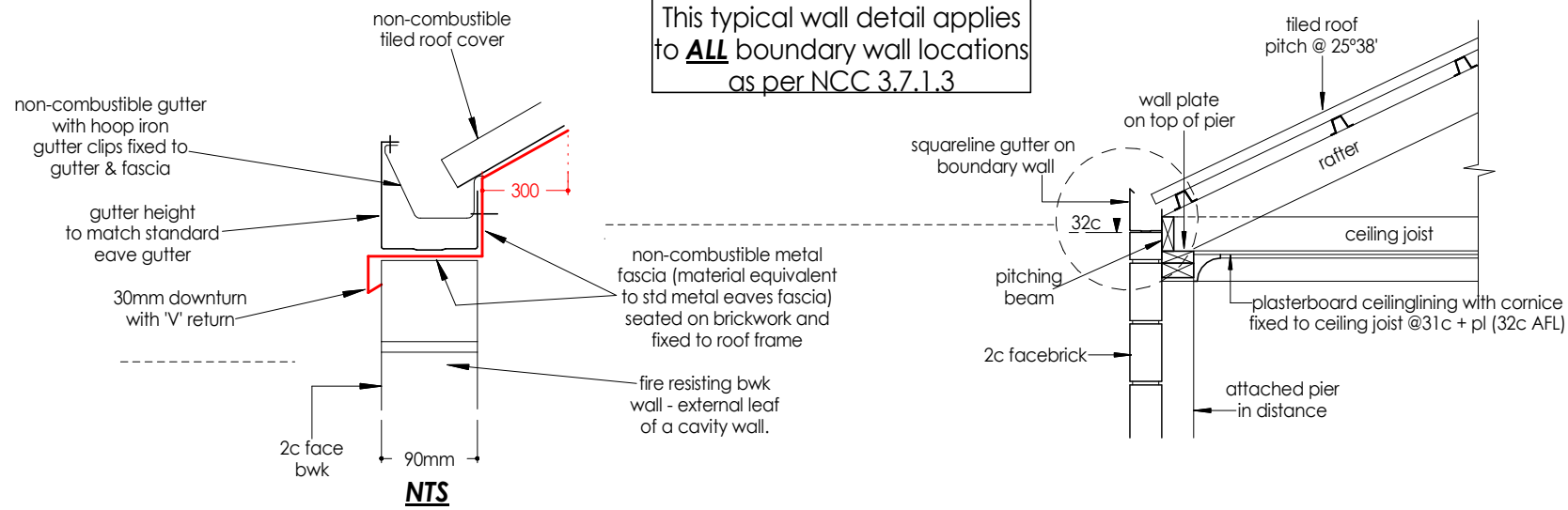

ROOF CONSTRUCTION NOTE
All roof structures to be constructed in accordance with the Australian Standards AS 1684.4-2010 Light timber framing code

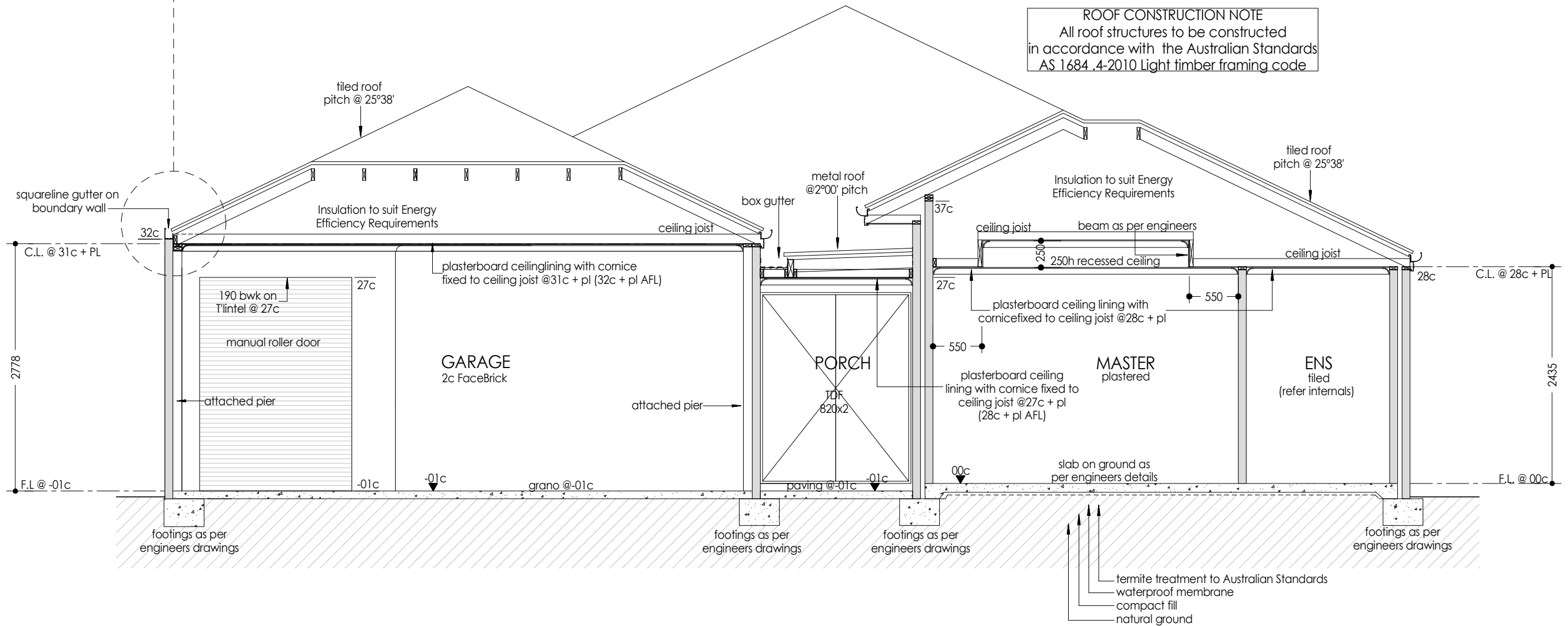

- termite treatment to Australian Standards
- waterproof membrane
- compact fill
- natural ground



URBAN WA
LOT 20 ENCORE RISE
LANDSDALE
CITY OF WANNEROO

JOB NUMBER 2024116		DRAWING NAME SECTION A-A	
START DATE JULY 2024	REVISION DESCRIPTION	IN.	DATE
SHEET 07 of 11	REVISION A	LJ	25/07/24
SCALE 1:50	WORKING DRAWINGS	TR	30/07/24
REVISION A	PRESTART	JH	17/09/24
	PLANNING COMMENTS	LJ	17/10/24

KTR CREATIONS
IMAGINE | CREATE | CONSTRUCT
BUILDING DESIGN AND DRAFTING
www.ktrcreations.com.au
design@ktrcreations.com.au
9381 2106
1 Carbonate Road,
Wangara, WA 6065

CONSTRUCTION NOTE:
All drawings to be reviewed and checked by the Builder, Client, Sub-Contractors or the like before commencement of any works. **No** responsibility will be accepted by KTR Creations if no correspondence was coordinated prior or during construction.
COPYRIGHT:
This plan shall remain the sole property of KTR Creations and must not be given, or resold and must not be reproduced or copied without the permission in writing by KTR Creations



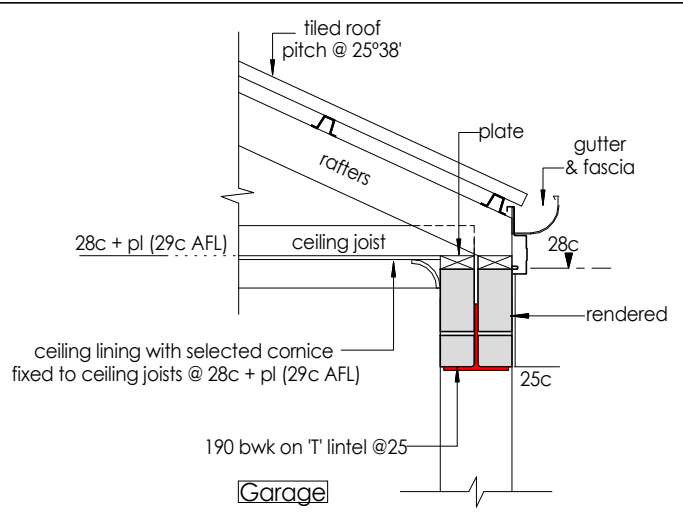

Garage
DETAIL 01

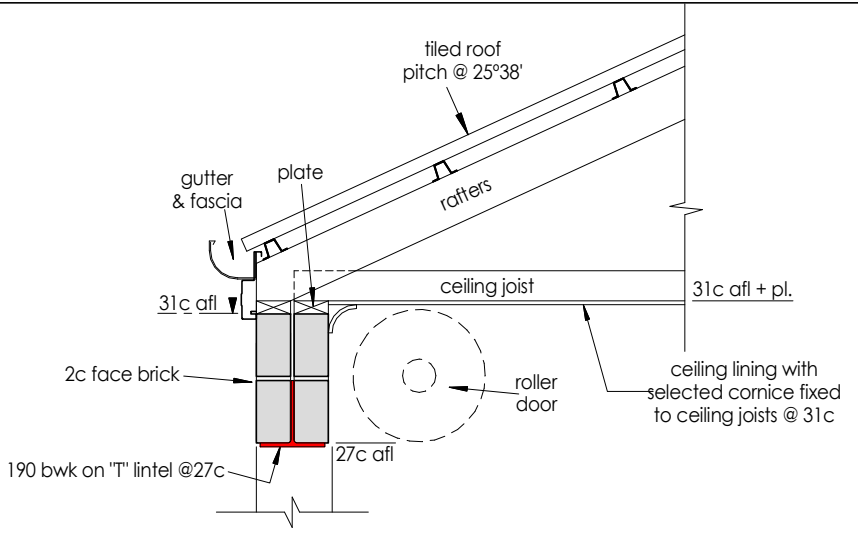

DETAIL 06

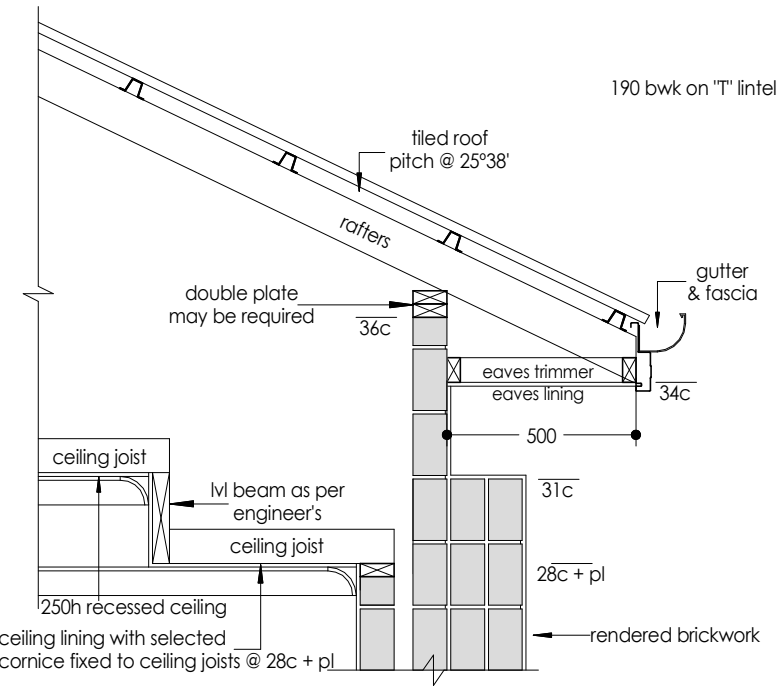

DETAIL 02 Master

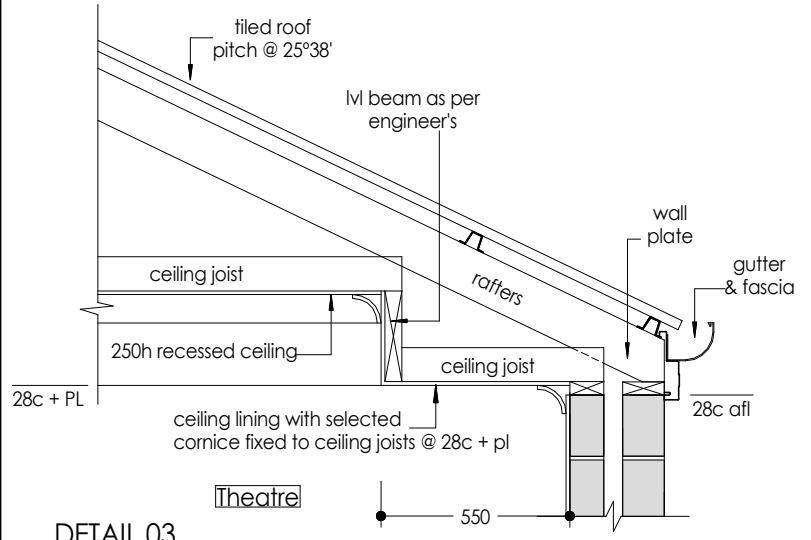

Theatre
DETAIL 03

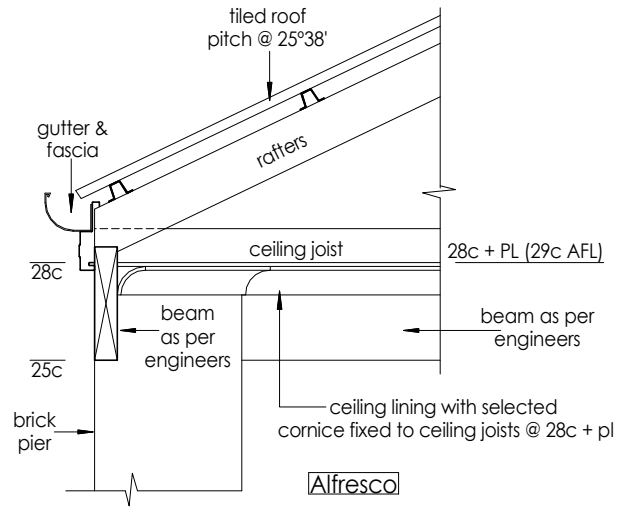

Alfresco
DETAIL 04

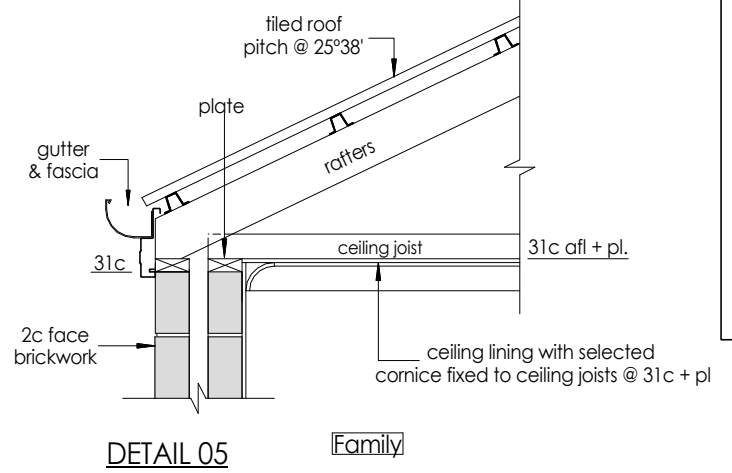

Family
DETAIL 05

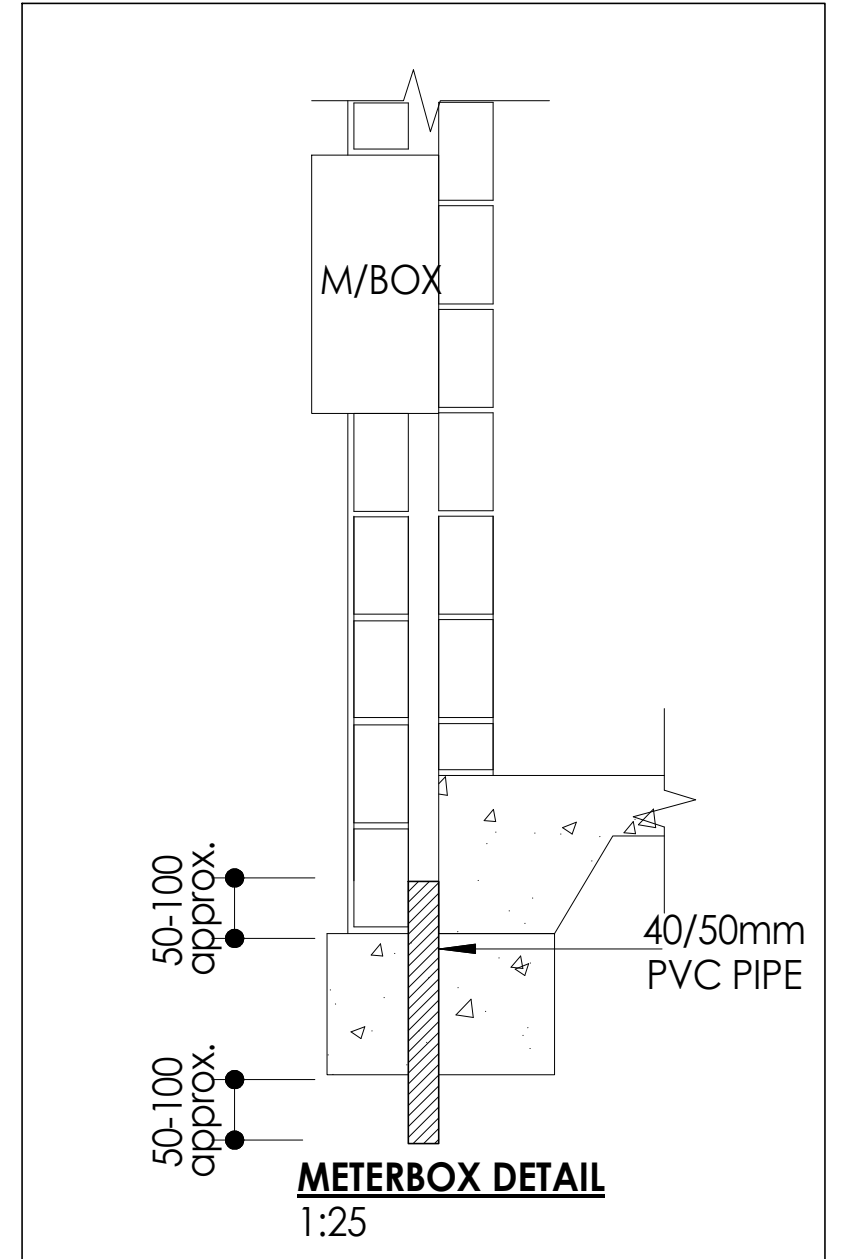

METERBOX DETAIL
1:25



URBAN WA
LOT 20 ENCORE RISE
LANDSDALE
CITY OF WANNEROO

JOB NUMBER 2024116		DRAWING NAME DETAILS	
START DATE JULY 2024	REVISION DESCRIPTION	IN.	DATE
SHEET 08 of 11	REVISION A	LJ	25/07/24
SCALE 1:50	PRESTART	JH	17/09/24
REVISION A	PLANNING COMMENTS	LJ	17/10/24

KTR CREATIONS
IMAGINE | CREATE | CONSTRUCT
BUILDING DESIGN AND DRAFTING
www.ktrcreations.com.au
design@ktrcreations.com.au
9381 2106
1 Carbonate Road,
Wangara, WA 6065

CONSTRUCTION NOTE:
All drawings to be reviewed and checked by the Builder, Client, Sub-Contractors or the like before commencement of any works. **No** responsibility will be accepted by KTR Creations if no correspondence was coordinated prior or during construction.
COPYRIGHT:
This plan shall remain the sole property of KTR Creations and must not be given, or resold and must not be reproduced or copied without the permission in writing by KTR Creations



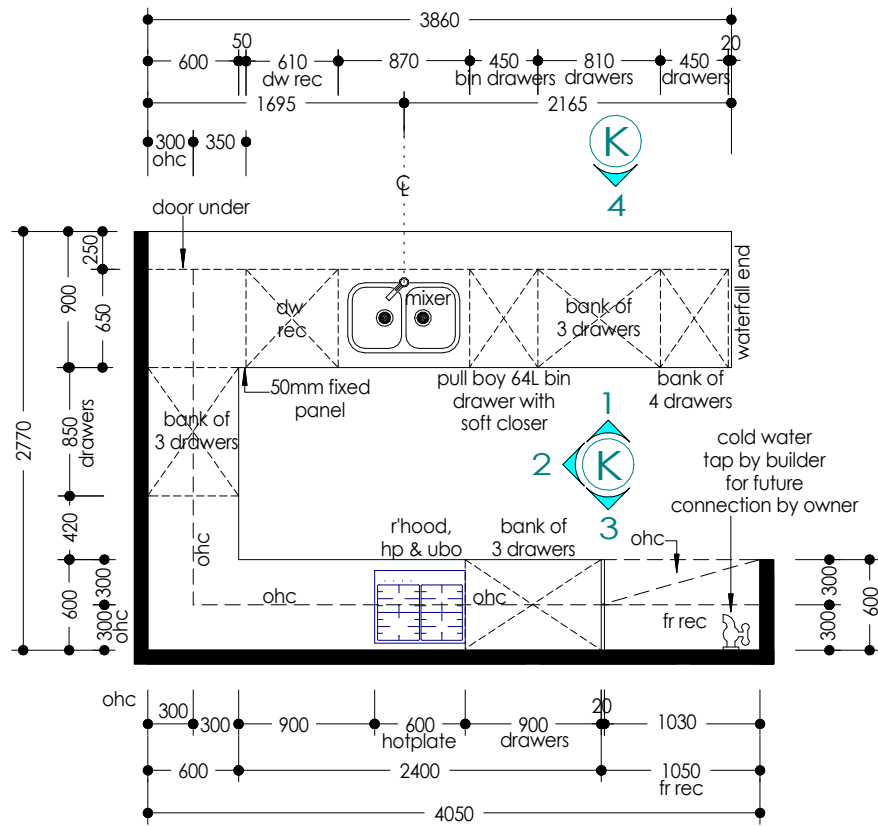

KITCHEN

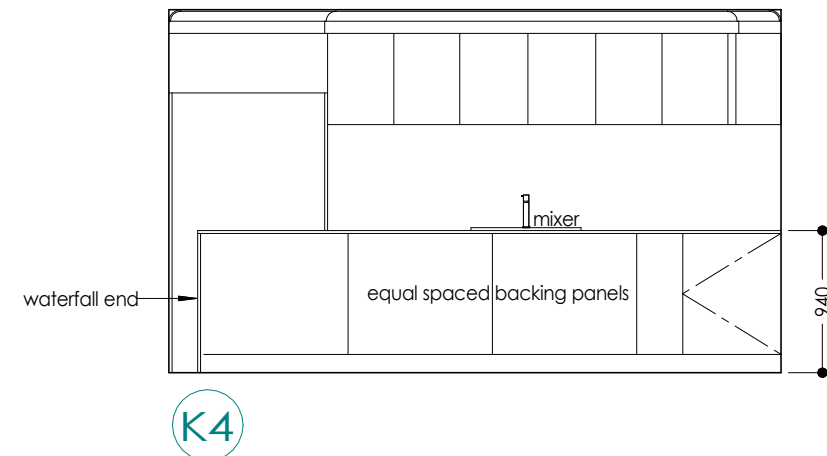
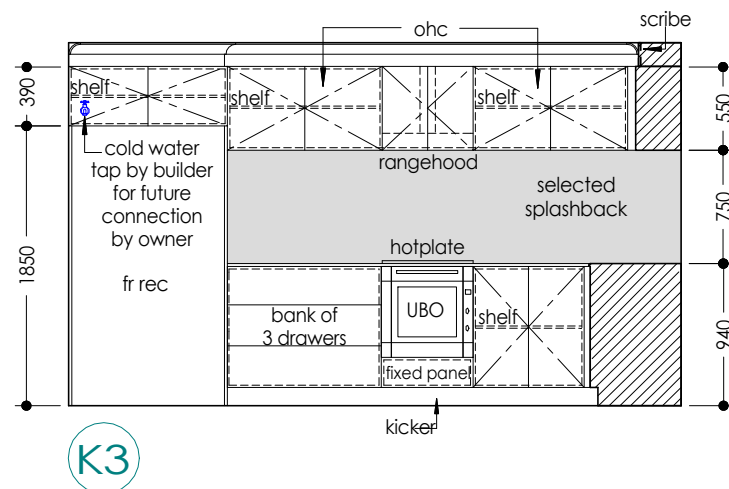
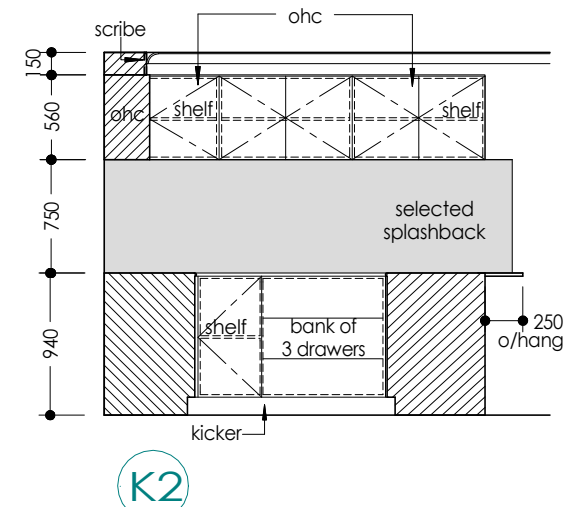
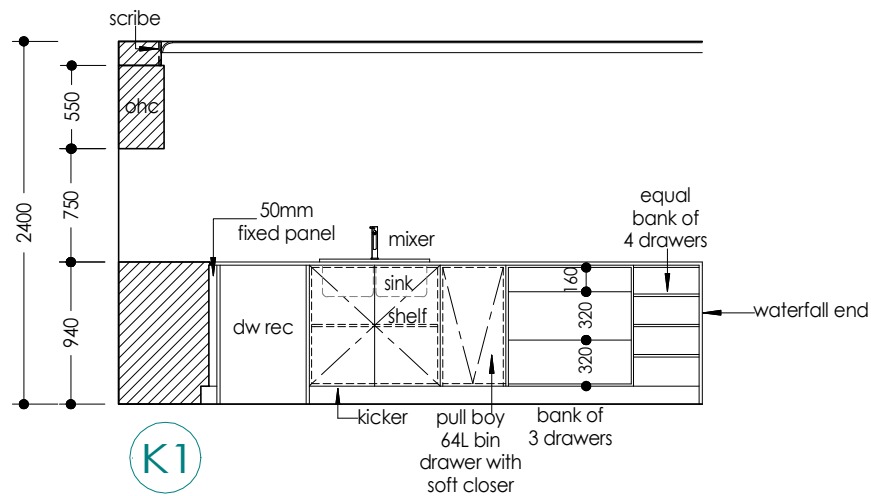

NOTE :
 DRAWINGS ARE INDICATIVE ONLY AND SITE MEASURE IS REQUIRED TO DETERMINE FINISHED DIMENSIONS
 ALL INTERNAL LAYOUTS TO BE DISCUSSED AND CONFIRMED WITH CLIENT
 ALL CABINERY TO BE CONFIRMED BY CHOSEN CABINET MAKER AND LIASED WTH CLIENT



URBAN WA

LOT 20 ENCORE RISE
 LANDSDALE
 CITY OF WANNEROO

JOB NUMBER 2024116		DRAWING NAME INTERNALS 1		KTR CREATIONS IMAGINE CREATE CONSTRUCT		
START DATE JULY 2024	REVISION DESCRIPTION PLANNING DRAWINGS	IN. LLV	DATE 17/07/24	BUILDING DESIGN AND DRAFTING www.ktrcreations.com.au design@ktrcreations.com.au 9381 2106 1 Carbonate Road, Wangara, WA 6065		
SHEET 09 of 11	REVISION A		LJ			25/07/24
SCALE 1:50	REVISION A	WORKING DRAWINGS	TR			30/07/24
		PRESTART	JH			17/09/24
		PLANNING COMMENTS	LJ			17/10/24

CONSTRUCTION NOTE:
 All drawings to be reviewed and checked by the Builder, Client, Sub-Contractors or the like before commencement of any works. No responsibility will be accepted by KTR Creations if no correspondence was coordinated prior or during construction.

COPYRIGHT:
 This plan shall remain the sole property of KTR Creations and must not be given, or resold and must not be reproduced or copied without the permission in writing by KTR Creations



LAUNDRY

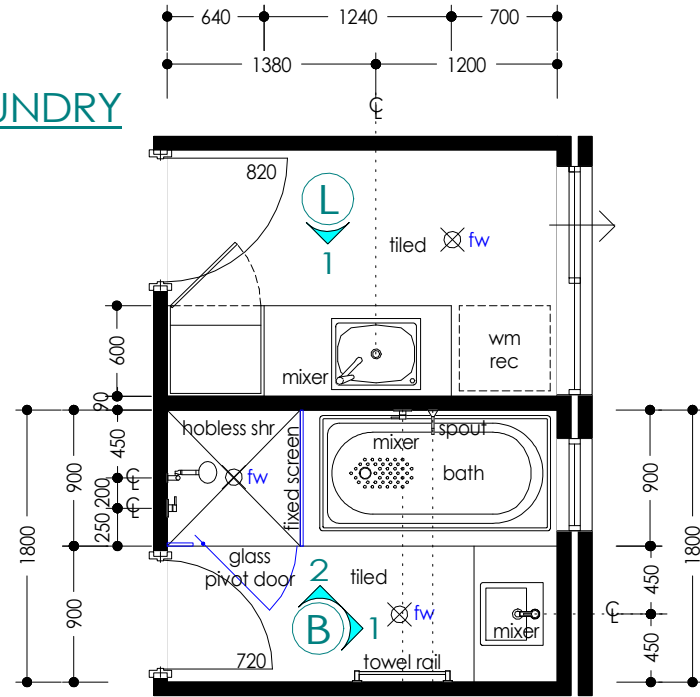

BATH

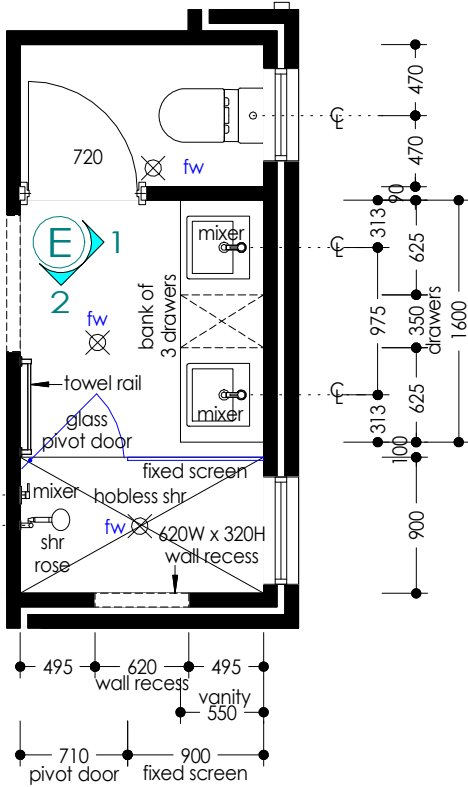
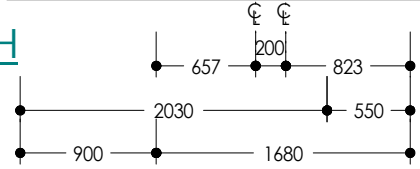

ENSUITE

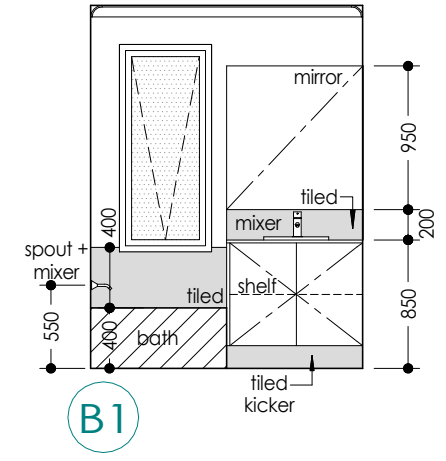
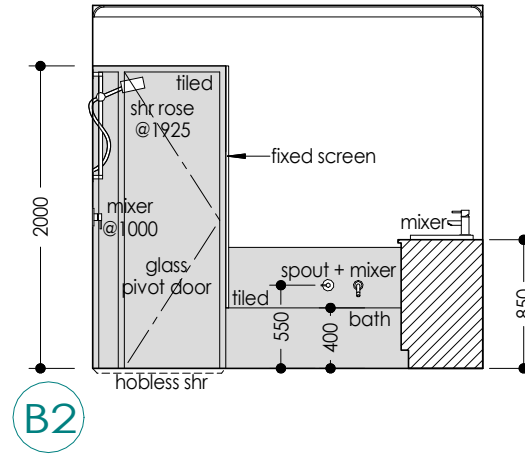
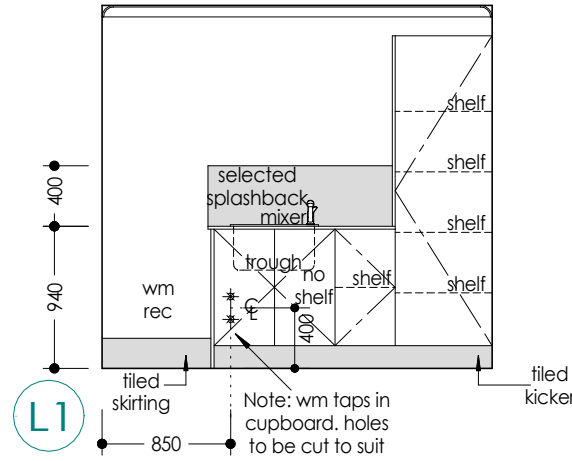

NOTE :
 DRAWINGS ARE INDICATIVE ONLY AND SITE MEASURE IS REQUIRED TO DETERMINE FINISHED DIMENSIONS
 ALL INTERNAL LAYOUTS TO BE DISCUSSED AND CONFIRMED WITH CLIENT
 ALL CABINETRY TO BE CONFIRMED BY CHOSEN CABINET MAKER AND LIASED WTH CLIENT

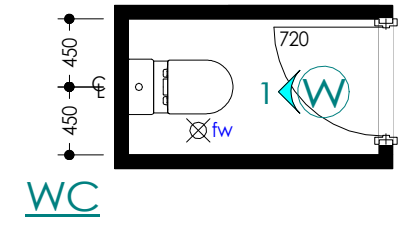

WC

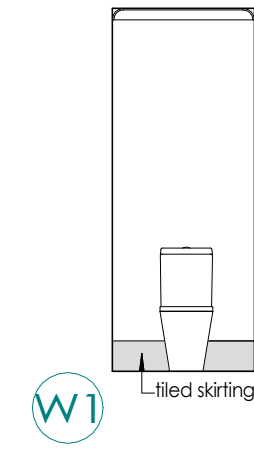
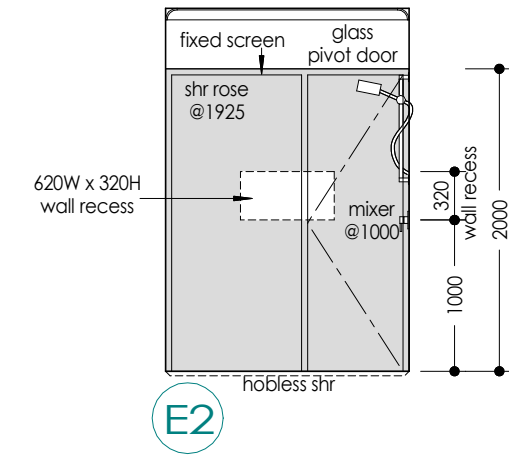
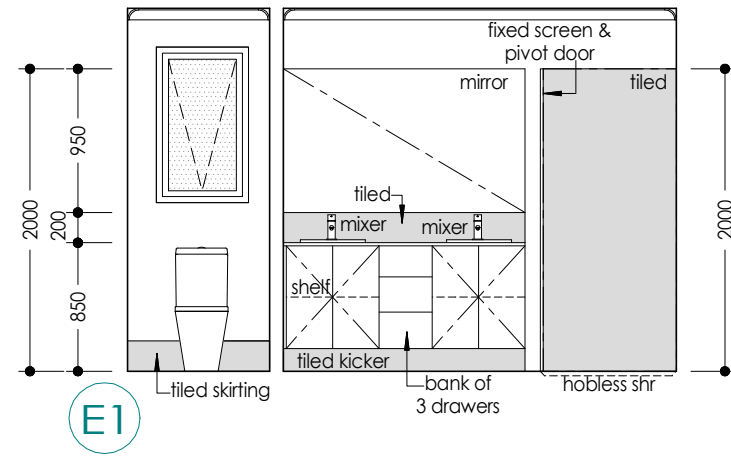

URBAN WA
 LOT 20 ENCORE RISE
 LANDSDALE
 CITY OF WANNEROO

JOB NUMBER 2024116		DRAWING NAME INTERNALS 2	
START DATE JULY 2024	REVISION DESCRIPTION PLANNING DRAWINGS	IN. LLV	DATE 17/07/24
SHEET 10 of 11	REVISION A	LJ	25/07/24
SCALE 1:50	WORKING DRAWINGS	TR	30/07/24
REVISION A	PRESTART	JH	17/09/24
	PLANNING COMMENTS	LJ	17/10/24

KTR CREATIONS
 IMAGINE | CREATE | CONSTRUCT
 BUILDING DESIGN AND DRAFTING
 www.ktrcreations.com.au
 design@ktrcreations.com.au
 9381 2106
 1 Carbonate Road,
 Wangara, WA 6065

CONSTRUCTION NOTE:
 All drawings to be reviewed and checked by the Builder, Client, Sub-Contractors or the like before commencement of any works. No responsibility will be accepted by KTR Creations if no correspondence was coordinated prior or during construction.
COPYRIGHT:
 This plan shall remain the sole property of KTR Creations and must not be given, or resold and must not be reproduced or copied without the permission in writing by KTR Creations



ELECTRICAL LEGEND	
	CEILING LIGHT
	WALL LIGHT (HEIGHT AS NOMINATED)
	DOWN LIGHT
	FLUORESCENT LIGHT - TWIN
	EXHAUST FAN W/ DAMPER FLUMED TO EXT. AIR
	TWIN HEAT LIGHT
	SMOKE DETECTOR
	GPO 300 A.F.L. - SINGLE
	GPO 300 A.F.L. - DOUBLE
	GPO HEIGHT AS NOMINATED - SINGLE
	GPO HEIGHT AS NOMINATED - DOUBLE
	GPO W/PROOF HEIGHT AS NOMINATED - SINGLE
	GPO W/PROOF HEIGHT AS NOMINATED - DOUBLE
	TELEPHONE POINT @ 300 A.F.L. (OR AS NOMINATED)
	T.V. POINT @ 300 A.F.L. (OR AS NOMINATED)
	TWO WAY SWITCHING
	PENDANT LIGHT
	DATA POINT
	300mm OYSTER LIGHT
	400mm OYSTER LIGHT
	Bunker light
	LIGHT SENSOR
	Alarm
	DIMMER SWITCH
	WALL CONDUIT
	CEILING SWEEP FAN
	CEILING SWEEP FAN WITH LIGHT
	CHANDERLIER/PENDANT

NOTE:
ELECTRICAL POINTS MAY BE RELOCATED ON SITE TO SUIT CURRENT STATUTORY REQUIREMENTS BY LICENCED ELECTRICIAN

NOTE:
HARDWIRED, INTERCONNECTED SMOKE ALARMS MUST BE INSTALLED IN ACCORDANCE WITH PART 3.5.7.3 OF THE BUILDING CODE AND AS 3786

NOTE:
-ALL G.P.O HEIGHTS NOMINATED ARE TO BASE OF G.P.O ABOVE FINISHED FLOOR LEVEL
-ALL LIGHT SWITCHES TO BE AT 1286mm (15c) ABOVE FINISHED FLOOR LEVEL UNLESS NOTED OTHERWISE

A/C NOTE:
CLIENT TO DISCUSS A/C REQUIREMENTS WITH A/C MANUFACTURER

NOTE:
* OWNER TO SUPPLIED FOR BUILDER TO INSTALL CEILING FAN TO MASTER (NOTE ADDITIONAL COSTS MAY BE INCURRED DUE TO COMPLEXITY OF PENDANT SUPPLIED)
* OWNER TO SUPPLIED FOR BUILDER TO INSTALL PENDANTS LIGHT (NOTE ADDITIONAL COSTS MAY BE INCURRED DUE TO COMPLEXITY OF PENDANT SUPPLIED)
* OWNER TO SUPPLIED FOR BUILDER TO INSTALL CEILING FAN LIGHT COMBO TO BED 2,3,4 AND ALFRESCO (NOTE ADDITIONAL COSTS MAY BE INCURRED DUE TO COMPLEXITY OF PENDANT SUPPLIED)
*WALL LIGHTS X 4 TO BE SUPPLIED BY OWNER

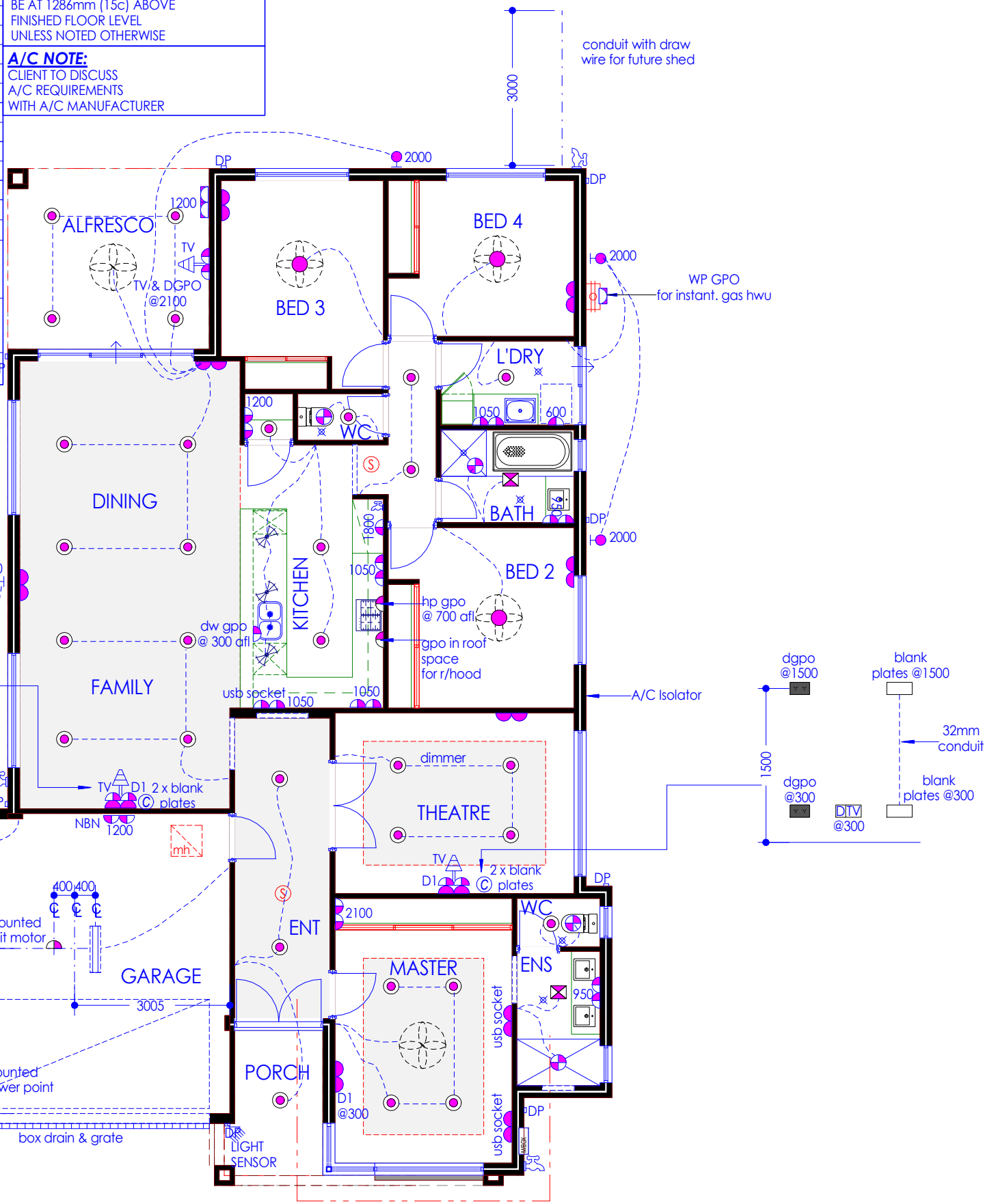

URBAN WA
LOT 20 ENCORE RISE
LANDSDALE
CITY OF WANNEROO

JOB NUMBER 2024116		DRAWING NAME GROUND ELECTRICAL	
START DATE JULY 2024	REVISION DESCRIPTION	IN.	DATE
SHEET 11 of 11	PLANNING DRAWINGS	LLV	17/07/24
SCALE 1:100	REVISION A	LJ	25/07/24
	WORKING DRAWINGS	TR	30/07/24
	PRESTART	JH	19/09/24
	PLANNING COMMENTS	LJ	17/10/24

KTR CREATIONS
IMAGINE | CREATE | CONSTRUCT
BUILDING DESIGN AND DRAFTING
www.ktrcreations.com.au
design@ktrcreations.com.au
9381 2106
1 Carbonate Road
Wangara WA 6065

CONSTRUCTION NOTE:
All drawings to be reviewed and checked by the Builder, Client, Sub-Contractors or the like before commencement of any works. No responsibility will be accepted by KTR Creations if no correspondence was coordinated prior or during construction.

COPYRIGHT:
This plan shall remain the sole property of KTR Creations and must not be given, or resold and must not be reproduced or copied without the permission in writing by KTR Creations