

STRUCTURAL GENERAL NOTES

1.0 General

- 1.1 These drawings are
 - a) Jointly owned by Easy Shed and Venn Engineering Pty Ltd
 - b) Provided for the sole purpose of obtaining building approval and guiding construction of a single building at the job address shown in the title block
 - c) Prohibited to be used for any other purpose without written authorisation from Easy Shed and Venn Engineering Pty Ltd.
 - d) Only valid if signed by the engineer and must not be altered in any way without signed approval from the engineer.
 - e) Produced to scale but dimensions shall not be obtained by measuring the drawings. All dimensions are in millimeters unless stated otherwise.
- 1.2 The engineer accepts no liability or responsibility for the contents of drawings that are invalid.
- 1.3 The word 'the engineer' used in these notes refers to an employee or nominated representative of Venn Engineering Pty Ltd.
- 1.4 The engineer is not the project manager or site supervisor for this project. It is the responsibility of the project manager or site supervisor in charge to ensure that the non-structural requirements of the Governing Building Code are considered and appropriately designed. This includes, but not limited to, fire & bushfire design, access requirements, future roof access requirements, lighting, glazing and electrical design, etc.

2.0 Structural Design

- 2.1 The structural framing components detailed in these drawings have been designed in accordance with the following documents for the design criteria detailed in these notes

Governing Building Code Loading Standards	2022 National Construction Code – Building Code of Australia Volume 2 and 2022 Housing Provisions Standard AS/NZS 1170.0:2002(+A5) AS/NZS 1170.1:2002(+A2) AS/NZS 1170.2:2021
Cold formed Steel member standard	AS/NZS 4600:2018
- 2.2 These drawings are also the limit of the Structural Design, any requirements for additional structural design of other items included in the project are specifically excluded if not shown on these drawings. This includes, but not limited to, requirements for additional loads that aren't specified including flood design loads, additional roof loads from solar panels, retaining walls required on site, driveway design etc.
- 2.3 These structural drawings and specifications represent the finished structure. The building is not considered complete until the installation of all components and details shown herein are installed according to the drawings.
- 2.4 No alterations are to be made to this structure without written approval of the engineer. This includes, but not limited to, modification to the plans and/or specifications, be the installation of additional openings, increased roof loads, skylight roof sheets or removal of cladding. If changes are made without written approval, such changes shall the legal and financial responsibility of the contractor or sub-contractors involved and it shall be their full responsibility to replace or repair the condition of the building as directed by the engineer.

3.0 Design Criteria

Building class.....	10a
Building Importance level.....	2
Wind region.....	B1
Terrain category.....	2.59
Topographic multiplier.....	1
Shielding multiplier.....	0.94
Ultimate design wind speed.....	43.9 m/s
Snow load.....	0.00 kPa
Slab imposed load.....	2.5 kPa or 9kN applied over 0.3x0.3m area (light vehicles)
Allowable bearing capacity of foundation supporting footings.....	100 kPa
Allowable bearing capacity of foundation supporting slab.....	50 kPa
Allowable skin friction of foundation.....	25 kPa
Soil Type.....	Non-aggressive (not saline or acid sulfate)

4.0 Installation Building Contractor Responsibilities

- 4.1 The contractor shall verify and confirm all site conditions and dimensions. Any discrepancies between drawings and site conditions shall be referred to the engineer for decision before proceeding with the work.
- 4.2 All workmanship and materials are to be in accordance with the Governing Building Code including all relevant Australian Standards and local statutory authorities except where varied by the contract documents.
- 4.3 The contractor shall be responsible for maintaining the structure in a stable condition and ensuring no part is overstressed under construction activities. They shall provide all temporary bracing, shoring or other means to avoid excessive stresses and to hold structural elements in place during erection. These temporary provisions shall remain in place until sufficient permanent members are erected to ensure the safety of partially erected structures. The contractor is responsible for meeting all laws regulating the erection of steel buildings including, but not limited to, Safe Work Australia guidelines.
- 4.4 The contractor shall be responsible for the location of all services in the vicinity of the works. Any services shown are provided for information only. The contractor shall confirm the location of all services prior to commencing and shall be responsible for the repair of any damage caused to services, as well as any loss incurred because of the damage to any service.

5.0 Foundation

- 5.1 The bearing capacity of the foundation supporting the footings and slab shall be confirmed before any concrete is placed.
- 5.2 No earth or debris is to fall into the footings or piers before and during placing of concrete.
- 5.3 All footings shall be located centrally under walls and columns unless noted otherwise.
- 5.4 Concrete embedment depths do not apply to locations where any uncompacted fill or disturbed ground exists or where walls of the excavation will not stand without support. Request further advice from the engineer in these circumstances.
- 5.5 Fill used for the support of a slab on ground shall be controlled fill or rolled fill as in accordance with clause 6.4.2 of AS 2870-2011.
- 5.6 Slabs less than 100sq.m in plan area are suitable for AS 2870-2011 site classes A, S & M. For larger slabs or for site classes M-D, H1, H1-D, H2, H2-D, E & E-D, the slab may experience cracking more than is considered normally acceptable. The cracking is considered of aesthetic concern only and should not effect the structural performance of the slab or shed. If this is not desired, contact the engineer for further advice.

6.0 Concrete

- 6.1 Concrete placement and workmanship shall be in accordance with AS 3600-2018 & AS 2870-2011.
- 6.2 Concrete shall be
 - a) N25 with slump of 100 mm in accordance with AS 1379-2007, with 20 mm maximum nominal aggregate size and no admixtures.
 - b) consolidated by mechanical vibration.
 - c) Cured for a minimum of 7 days using continuous ponding with potable water.
- 6.3 No holes, chases or embedment of pipes other than those shown on the drawings shall be made in concrete members without prior approval of the engineer.

7.0 Reinforcement

- 7.1 Reinforcement shall comply with AS/NZ 4671-2019.
- 7.2 Reinforcement is represented diagrammatically and not necessarily shown in true projection.
- 7.3 Welding of reinforcement shall not be permitted without the approval of the engineer.
- 7.4 All reinforcement shall be securely supported in its correct position ensuring the correct cover during placing of concrete by approved bar chairs, spacers or support bars. Approved chairs include stainless steel or plastic bar chairs for bottom reinforcement and plastic tipped wire bar chairs for top reinforcement. All chairs to be spaced at maximum of 750mm centres.
- 7.5 Cover to reinforcement shall be:
 - a) 50mm for surfaces of concrete in contact with the ground;
 - b) 30mm for top surfaces of slabs fully enclosed by the building without open bays or
 - c) 60mm for top surfaces of slabs more than 1 km from the coastline with open bays.
 - d) For buildings with open bays within 1km of the coast, contact the engineer for cover and concrete grade requirements.
- 7.6 Reinforcement shall be lapped 500mm for 12mmØ bars and 800mm for 16mmØ bars.
- 7.7 Mesh reinforcement shall be lapped such that the two outermost wires of one sheet overlap the two outermost wires of the other sheet by 25 mm.
- 7.8 Hooks, bends and cogs to be in accordance with AS 3600-2018 unless noted otherwise on drawings.

8.0 Anchor Bolts

- 8.1 All anchors bolts shall be installed in accordance with the manufacturer's installation instructions.
- 8.2 Drill holes using a percussion drill (coring not permitted) to the correct hole diameter and depth as specified in the drawings.
- 8.3 Thoroughly clean and blow the dust out of the holes using the cleaning accessories prescribed by the manufacturer's instructions.
- 8.4 Substitution of anchors bolts and chemical epoxy adhesive is not permitted unless written confirmation from the engineer is provided.
- 8.5 For chemical anchors, ensure load is not applied to the anchors whilst epoxy adhesive is curing.

9.0 Light Gauge Cold-formed Steel

- 9.1 All light gauge cold-formed steel shall comply with AS 1397-2021 and be the following grades

Thickness(mm)	Steel grade (yield stress, MPa)	Protective coating (g/m2)
BMT ≤ 1.0mm	G550	Z350
1.0mm < BMT < 1.5mm	G500	Z350
1.5mm ≤ BMT ≤ 3.0mm	G450	Z350
- 9.2 Welding of light gauge cold-formed steel shall not be permitted.
- 9.3 Column and rafter members shall not be drilled or notched without prior approval of the engineer.
- 9.4 Round holes may be drilled through any girt or purlin member within the middle third of the depth of that member and not within 600mm of member end unless noted otherwise.
- 9.5 All bolts used to connect light gauge cold-formed steel members shall be
 - a) Zinc coated M12 (min.) grade 4.6 snug tightened complying to AS 1111.1-2015 & AS 1112.3-2015 unless noted otherwise.
 - b) Spaced no less than 3 bolt diameters between centres.
 - c) Located no less than 1.5 bolt diameters from bolt centre to the end or edge of any light gauge member.
- 9.6 All screws used to connect light gauge cold formed steel members (excluding sheeting) shall be
 - a) 10g (min.) self-drilling screws complying with AS 3566.1-2002.
 - b) Corrosion resistance class 4 in accordance with AS 3566.2-2002 for buildings within 1 km from the coastline with open bays or class 3 otherwise.
 - c) Spaced no less than 3 bolt diameters between centres.
 - d) Located no less than 1.5 bolt diameters from bolt centre to the end or edge of any light gauge member.

10.0 Roof & Wall Sheeting

- 10.1 Roof & wall sheeting shall comply with AS 1397-2018 and have suitable corrosion protection complying with Table 7.2.2a of the 2022 Housing Provisions Standard.
- 10.2 During construction and maintenance, no foot traffic shall occur within end spans of sheeting, foot traffic shall occur
 - a) Evenly across at least two ribs for corrugated profiled sheeting or
 - b) In the pans for pan-type profiled sheeting.
- 10.3 Any roof skylights shall be approved by the engineer
- 10.4 Safety mesh shall be installed in accordance with the building code

11.0 Door & Window Components

- 11.1 Wind-locked roller doors are assumed to remain in-place and resist the ultimate limit state wind loading except for in cyclonic regions
- 11.2 Non-wind-locked roller doors are assumed to have failed at the ultimate limit state wind loading
- 11.3 Personal access doors shall be rated for the wind loading parameters stated in the design criteria (see section 3.0)
- 11.4 All windows shall be in accordance with AS 1288-2021 & AS 2047-2014(+A2) as appropriate for the wind loading parameters stated in the design criteria (see section 3.0)

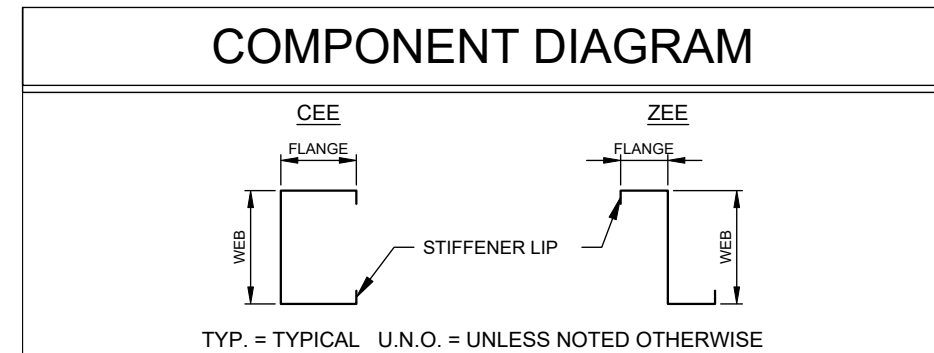

REV	DATE	DESCRIPTION
A	25-03-2025	-

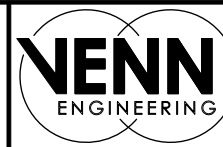

PO Box 3084
THIRROUL NSW 2515
sheds@venn.engineering
ABN 39 626 802 257

Signed *[Signature]* Date 25-03-2025
Grant J Wood MIEAust CPEng NER RPEQ
Registered EA Chartered Professional Engineer (No. 2383009)
Registered Professional Engineer QLD (No. 14384)
Registered Civil Engineer Building Practitioner VIC (No. PE0002499)
Registered Certifying Engineer (structural) NT (No. 306371ES)
Building Services Provider (Engineer Civil) TAS (No. 699339425)

Customer Name: Luke Bailey
Site Address: 9 Br Ted Magee Rd
Collingwood Park,
QLD, 4301

DATE 25-03-2025
JOB NO. EALB99982966
SHEET 1 of 9

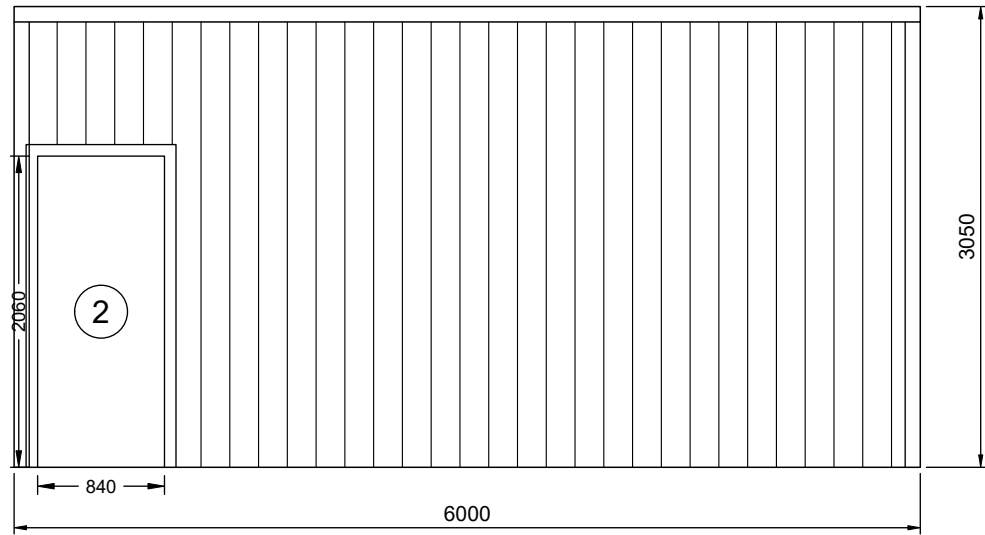

2 SIDEWALL B BUILDING ELEVATION
2 SCALE: 1:50

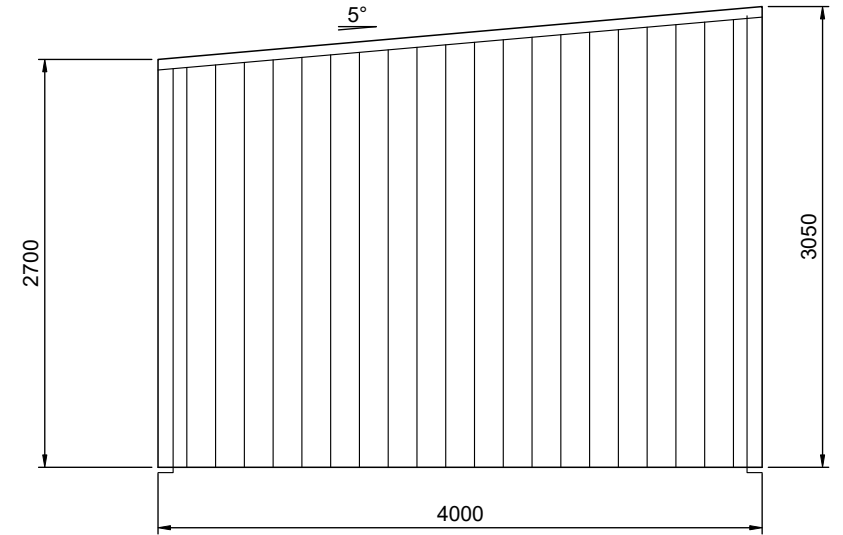

3 REAR BUILDING ELEVATION
2 SCALE: 1:50 FRAME #3

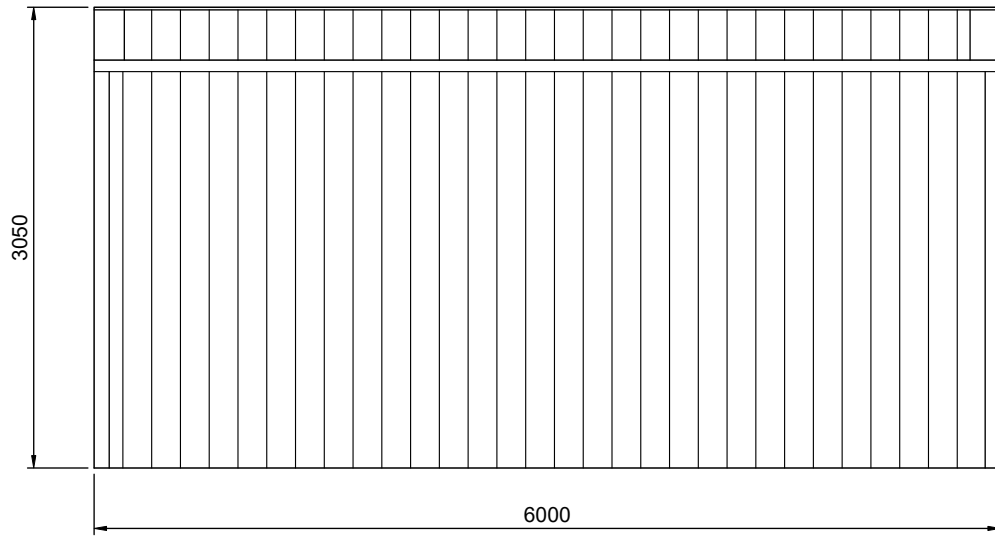

1 SIDEWALL A BUILDING ELEVATION
2 SCALE: 1:50

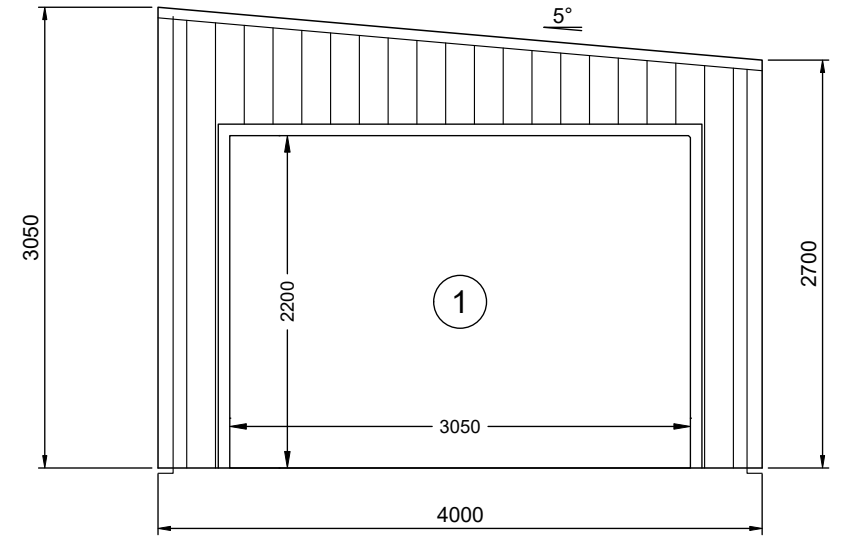

4 FRONT BUILDING ELEVATION
2 SCALE: 1:50 FRAME #1

REV	DATE	DESCRIPTION
A	25-03-2025	-

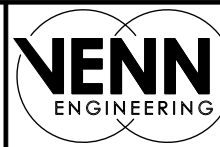

PO Box 3084
 THIRROUL NSW 2515
 sheds@venn.engineering
 ABN 39 626 802 257

Signed *[Signature]* Date 25-03-2025
 Grant J Wood MIEAust CPEng NER RPEQ
 Registered EA Chartered Professional Engineer (No. 2383009)
 Registered Professional Engineer QLD (No. 14384)
 Registered Civil Engineer Building Practitioner VIC (No. PE0002499)
 Registered Certifying Engineer (structural) NT (No. 306371ES)
 Building Services Provider (Engineer Civil) TAS (No. 69933425)

Customer Name: Luke Bailey
 Site Address: 9 Br Ted Magee Rd
 Collingwood Park,
 QLD, 4301

DATE 25-03-2025
 JOB NO. EALB99982966
 SHEET 2 of 9

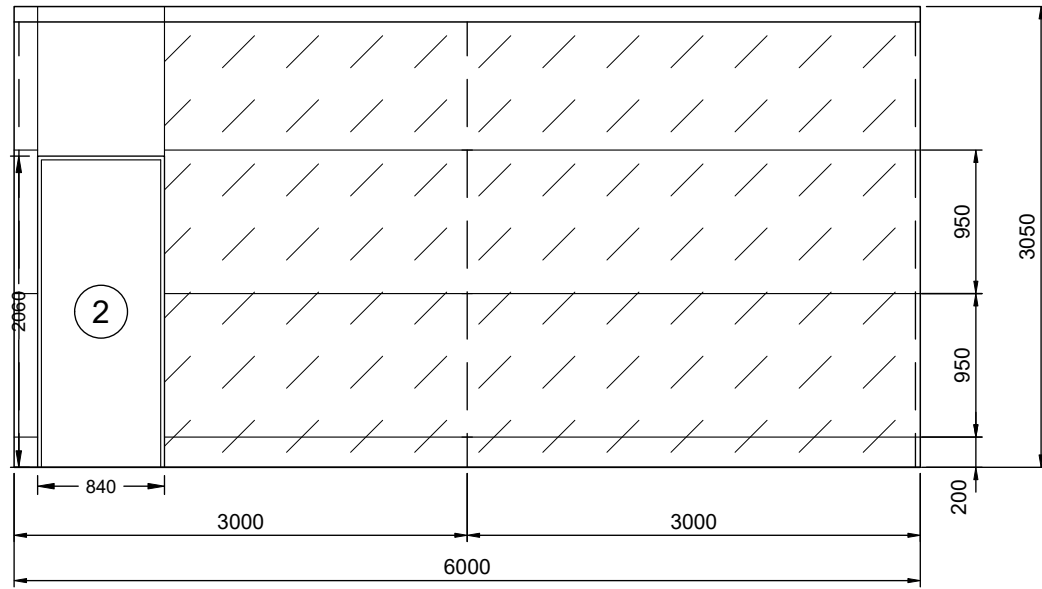

2 SIDEWALL B FRAMING ELEVATION

3 SCALE: 1:50

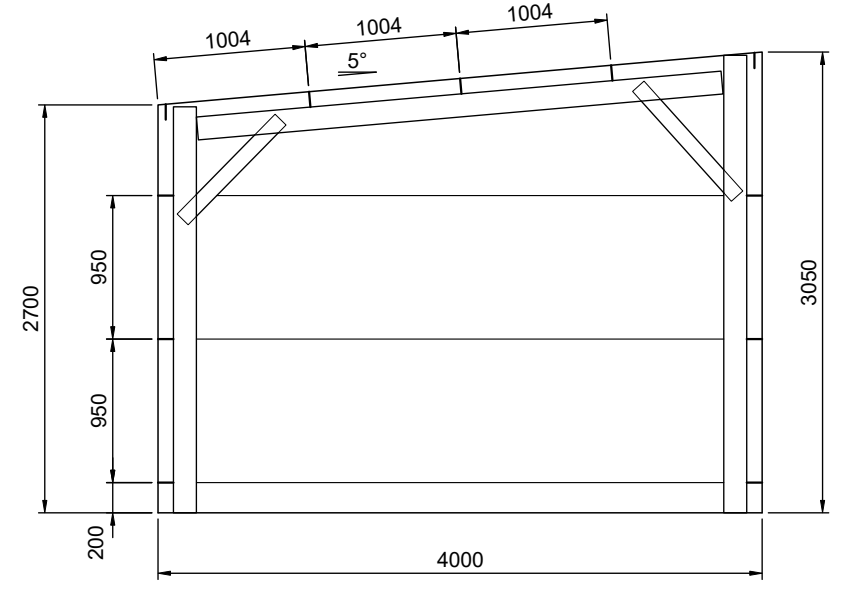

3 REAR FRAMING ELEVATION

3 SCALE: 1:50 FRAME #3

DIAPHRAGM SCHEDULE
SHEETING IN DIAPHRAGM SECTIONS (SHOWN AS HATCHED AREA ON ELEVATIONS) NOT TO BE CUT UNDER ANY CIRCUMSTANCES

WALL	DISTANCE FROM WALL EDGE
Sidewall 'A'	0-6000
Sidewall 'B'	0-5004

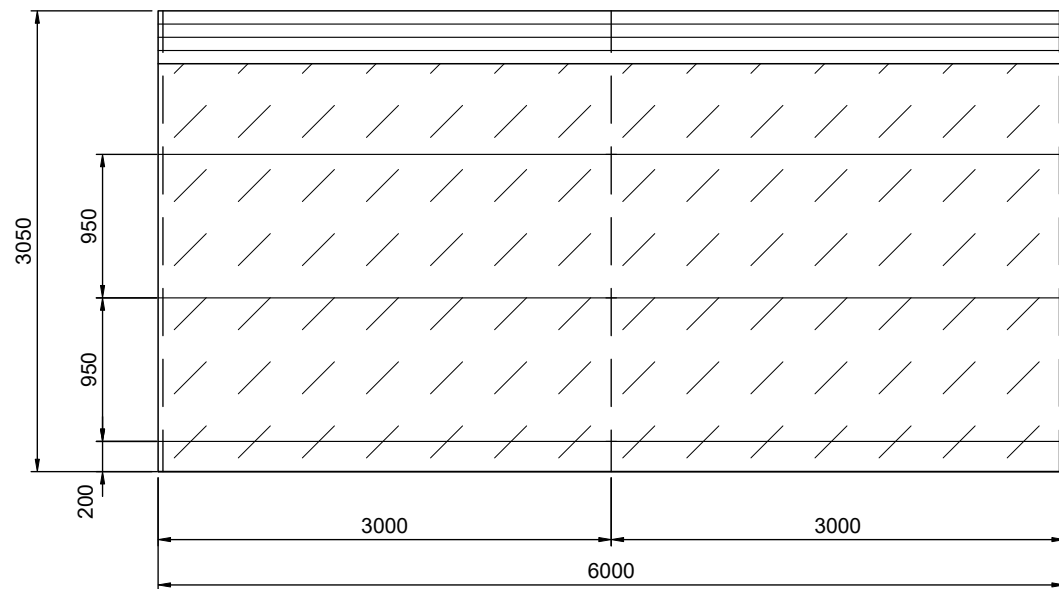

1 SIDEWALL A FRAMING ELEVATION

3 SCALE: 1:50

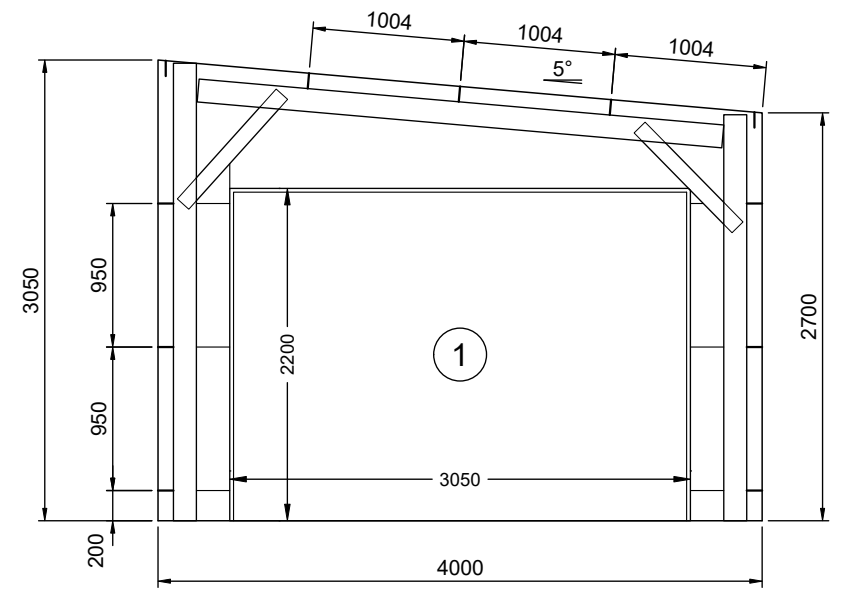

4 FRONT FRAMING ELEVATION

3 SCALE: 1:50 FRAME #1

REV	DATE	DESCRIPTION
A	25-03-2025	-



ANOTHER
COLD FORMED BUILDING
DESIGNED BY
ACT BUILDING SYSTEMS

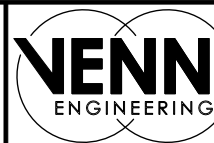

PO Box 3084
THIRROUL NSW 2515
sheds@venn.engineering
ABN 39 626 802 257

Signed *[Signature]* Date 25-03-2025
Grant J Wood MIEAust CPEng NER RPEQ
Registered EA Chartered Professional Engineer (No. 2383009)
Registered Professional Engineer QLD (No. 14384)
Registered Civil Engineer Building Practitioner VIC (No. PE0002499)
Registered Certifying Engineer (structural) NT (No. 306371ES)
Building Services Provider (Engineer Civil) TAS (No. 669339425)

Customer Name: Luke Bailey
Site Address: 9 Br Ted Magee Rd
Collingwood Park,
QLD, 4301

DATE 25-03-2025
JOB NO. EALB99982966
SHEET 3 of 9

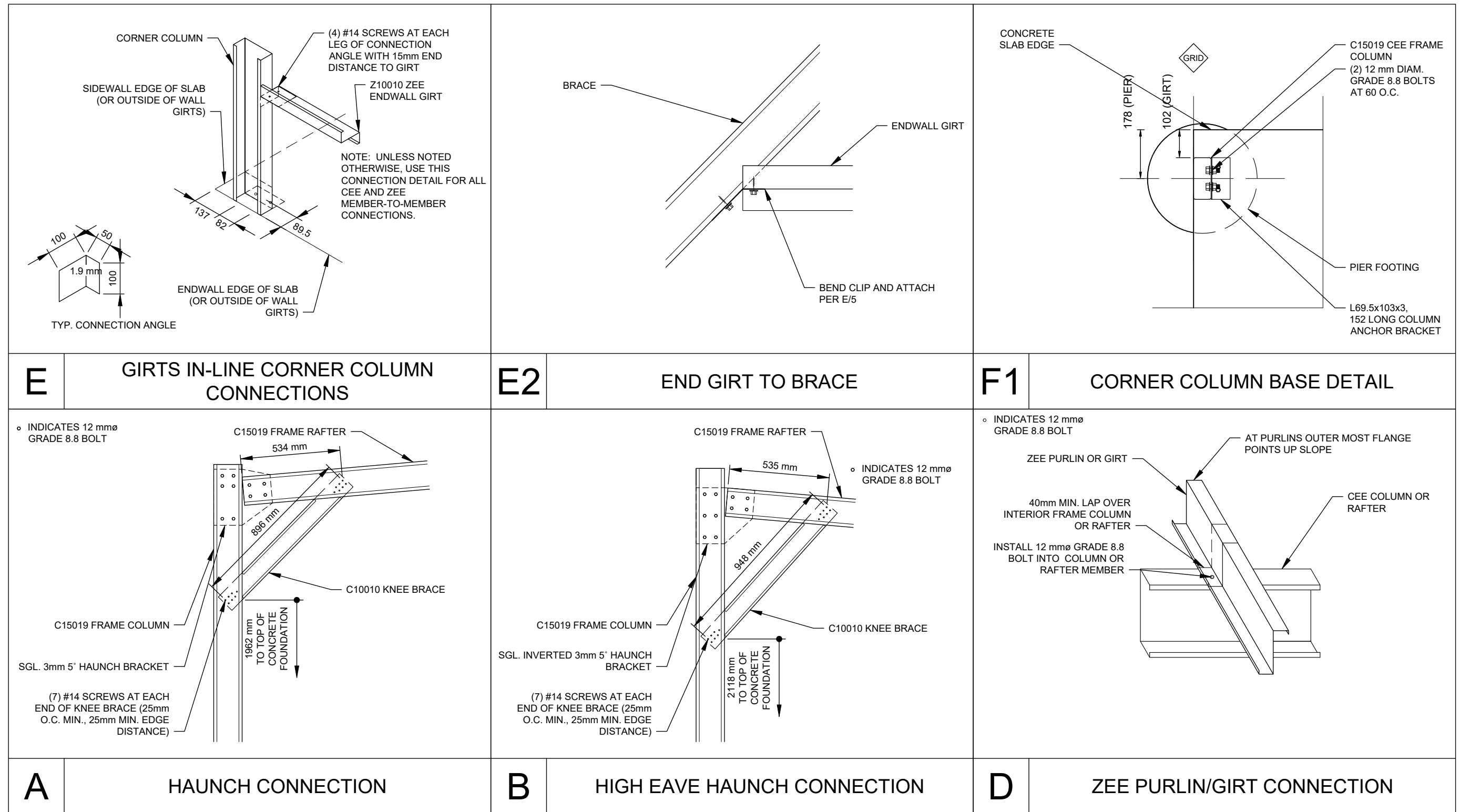

DETAIL DIMENSIONS ARE SHOWN IN MM UNLESS SPECIFIED OTHERWISE

REV	DATE	DESCRIPTION
A	25-03-2025	-

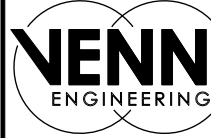

PO Box 3084
 THIRROUL NSW 2515
 sheds@venn.engineering
 ABN 39 626 802 257

Signed *[Signature]* Date 25-03-2025
 Grant J Wood MIEAust CPEng NER RPEQ
 Registered EA Chartered Professional Engineer (No. 2383009)
 Registered Professional Engineer QLD (No. 14384)
 Registered Civil Engineer Building Practitioner VIC (No. PE0002499)
 Registered Certifying Engineer (structural) NT (No. 306371ES)
 Building Services Provider (Engineer Civil) TAS (No. 669339425)

Customer Name: Luke Bailey
 Site Address: 9 Br Ted Magee Rd
 Collingwood Park,
 QLD, 4301

DATE 25-03-2025
 JOB NO. EALB99982966
 SHEET 5 of 9

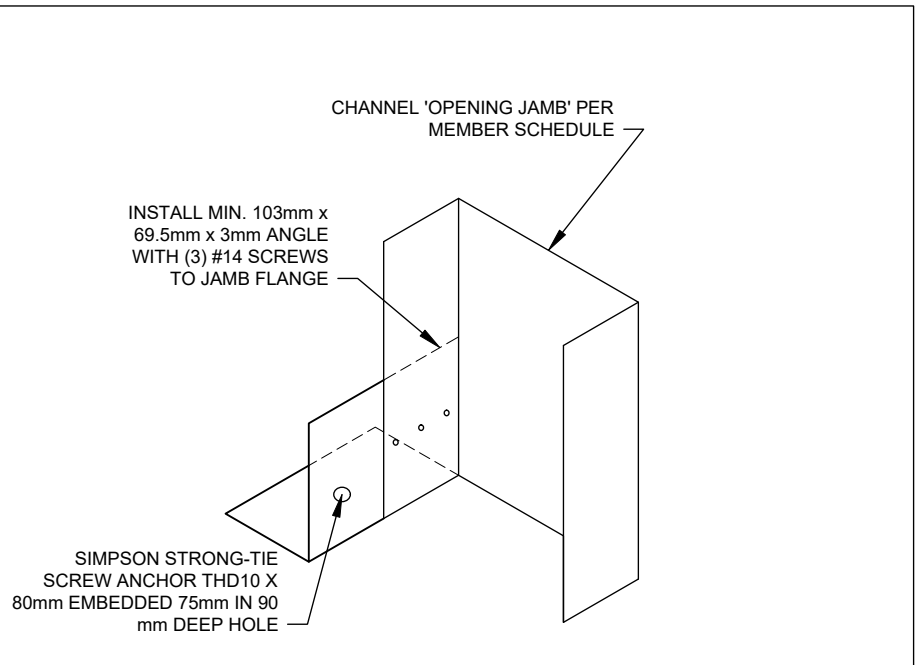
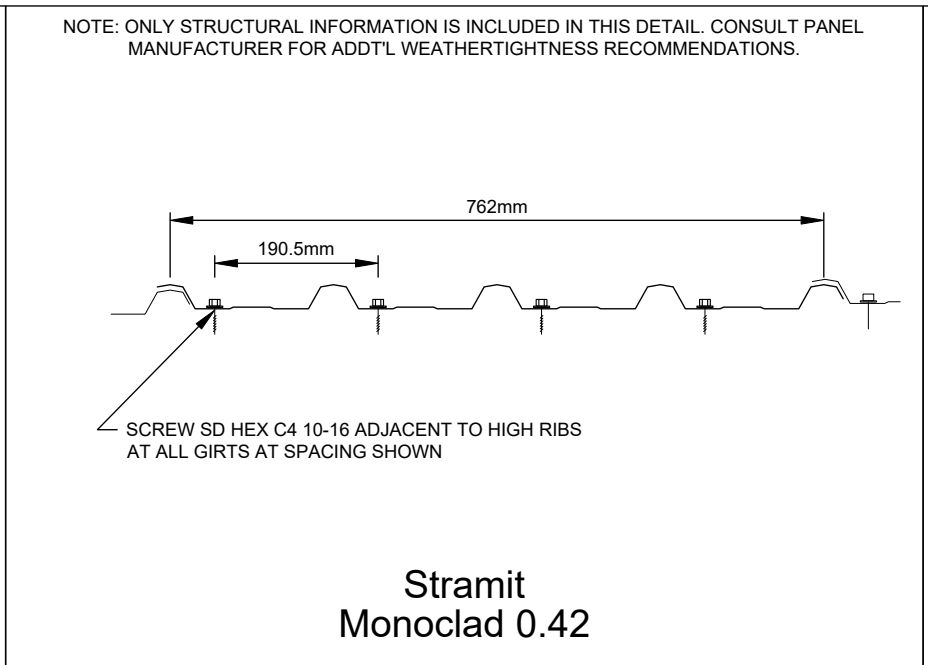
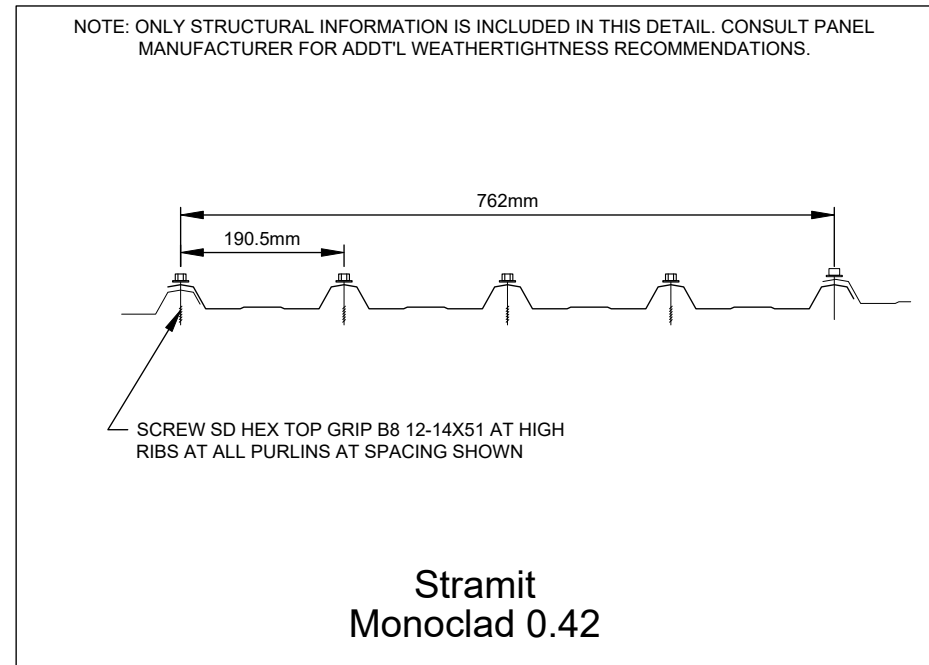

H ROOF SHEETING

I WALL SHEETING

J1 PA DOOR JAMB BASE CONNECTION

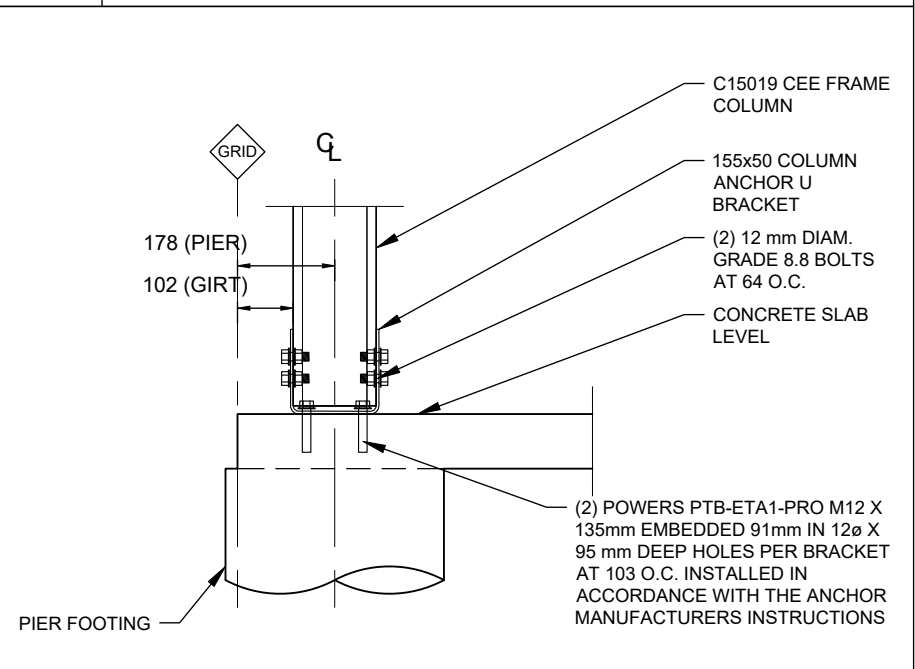
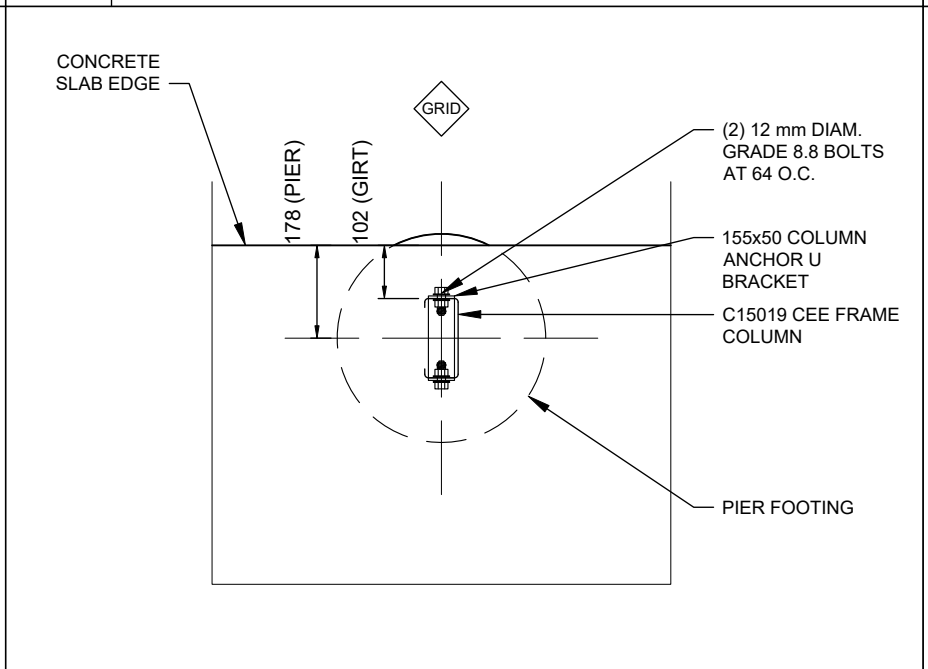
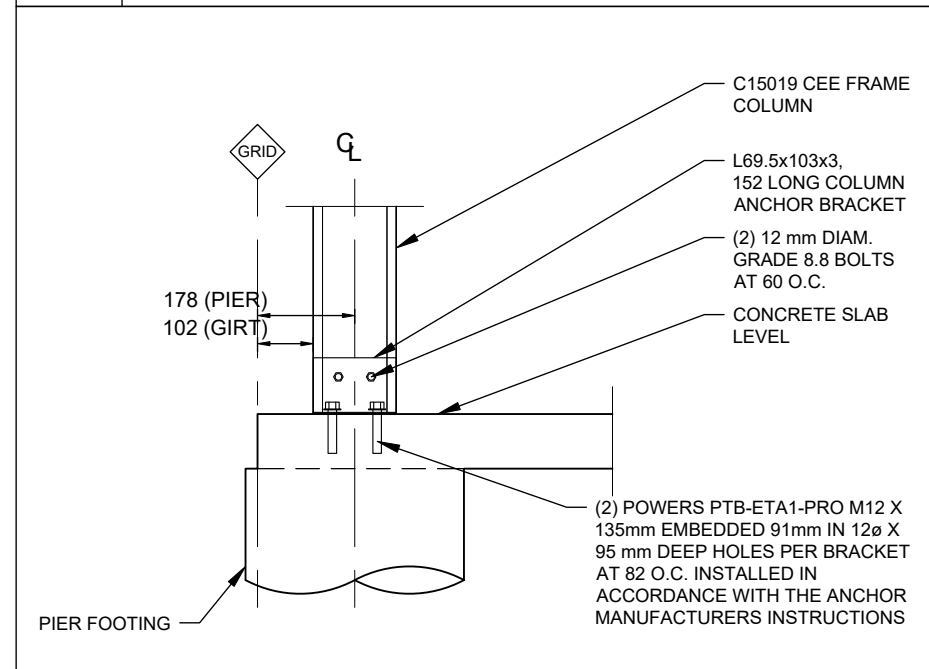

F2 CORNER COLUMN BASE DETAIL 2

F3 FRAME COLUMN BASE DETAIL

F4 FRAME COLUMN BASE DETAIL 2

DETAIL DIMENSIONS ARE SHOWN IN MM UNLESS SPECIFIED OTHERWISE

REV	DATE	DESCRIPTION
A	25-03-2025	-

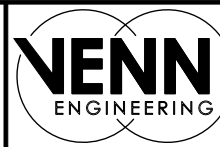

PO Box 3084
THIRROUL NSW 2515
sheds@venn.engineering
ABN 39 626 802 257

Signed *[Signature]* Date 25-03-2025
Grant J Wood MIEAust CPEng NER RPEQ
Registered EA Chartered Professional Engineer (No. 2383009)
Registered Professional Engineer QLD (No. 14384)
Registered Civil Engineer Building Practitioner VIC (No. PE0002499)
Registered Certifying Engineer (structural) NT (No. 306371ES)
Building Services Provider (Engineer Civil) TAS (No. 699339425)

Customer Name: Luke Bailey
Site Address: 9 Br Ted Magee Rd
Collingwood Park,
QLD, 4301

DATE 25-03-2025
JOB NO. EALB99982966
SHEET 6 of 9

		<p>ALL NUTS AND BOLTS TO HAVE WASHER OR FLANGED HEADS</p>
<p>L CHANNEL JAMB TO CEE CONNECTION</p>	<p>O EAVE PURLIN BRACKET</p>	<p>T BOLT OPTIONS</p>
<p>J2 ROLLER DOOR JAMB BASE CONNECTION</p>	<p>K1 OPENING CHANNEL JAMB GIRT CONNECTION</p>	<p>K2 OPENING ZEE JAMB GIRT CONNECTION</p>

DETAIL DIMENSIONS ARE SHOWN IN MM UNLESS SPECIFIED OTHERWISE

REV	DATE	DESCRIPTION
A	25-03-2025	-

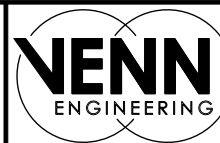

PO Box 3084
THIRROUL NSW 2515
sheds@venn.engineering
ABN 39 626 802 257

Signed *[Signature]* Date 25-03-2025
Grant J Wood MIEAust CPEng NER RPEQ
Registered EA Chartered Professional Engineer (No. 2383009)
Registered Professional Engineer QLD (No. 14384)
Registered Civil Engineer Building Practitioner VIC (No. PE0002499)
Registered Certifying Engineer (structural) NT (No. 306371ES)
Building Services Provider (Engineer Civil) TAS (No. 69933425)

Customer Name: Luke Bailey
Site Address: 9 Br Ted Magee Rd
Collingwood Park,
QLD, 4301

DATE 25-03-2025
JOB NO. EALB99982966
SHEET 7 of 9

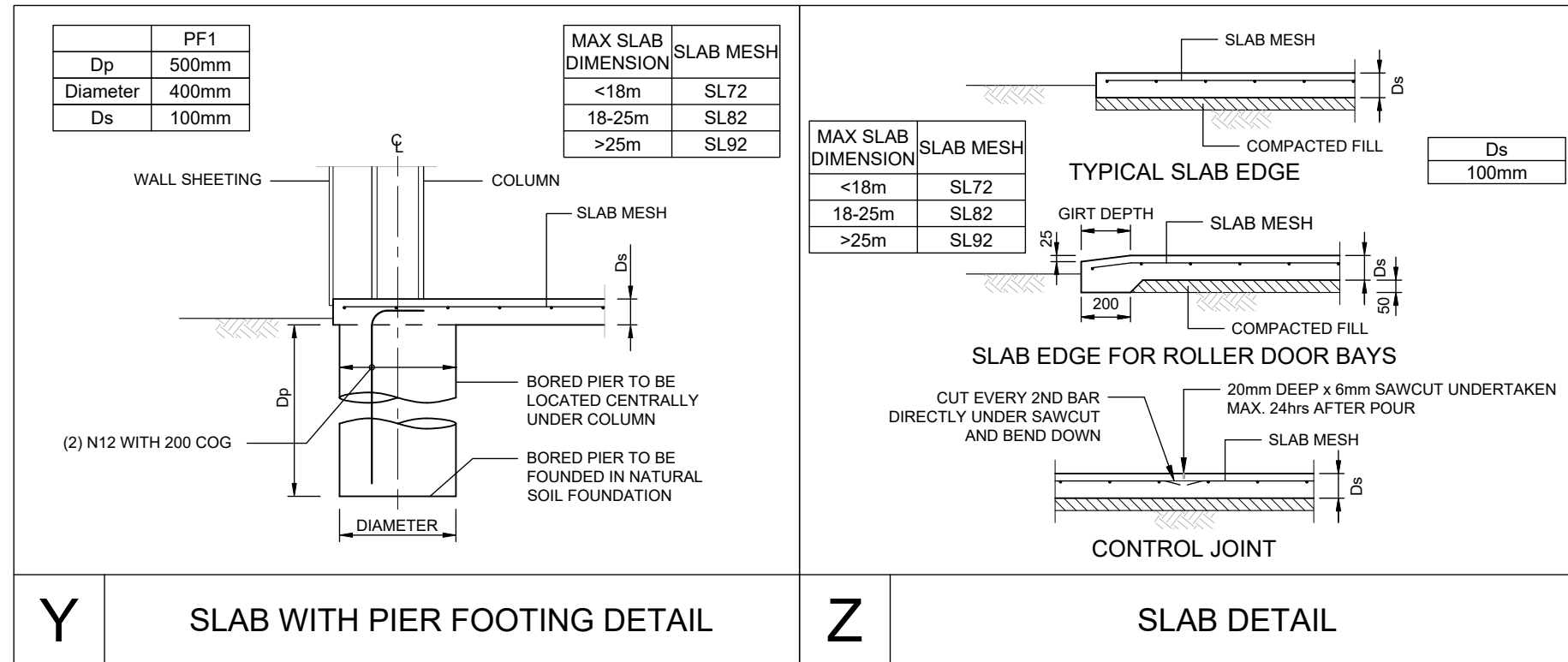

DETAIL DIMENSIONS ARE SHOWN IN MM UNLESS SPECIFIED OTHERWISE

REV	DATE	DESCRIPTION
A	25-03-2025	-

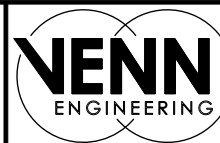

PO Box 3084
THIRROUL NSW 2515
sheds@venn.engineering
ABN 39 626 802 257

Signed *[Signature]* Date 25-03-2025

Grant J Wood MIEAust CPEng NER RPEQ
Registered EA Chartered Professional Engineer (No. 2383009)
Registered Professional Engineer QLD (No. 14384)
Registered Civil Engineer Building Practitioner VIC (No. PE0002499)
Registered Certifying Engineer (structural) NT (No. 306371ES)
Building Services Provider (Engineer Civil) TAS (No. 699339425)

Customer Name: Luke Bailey
Site Address: 9 Br Ted Magee Rd
Collingwood Park,
QLD, 4301

DATE 25-03-2025
JOB NO. EALB99982966
SHEET 8 of 9

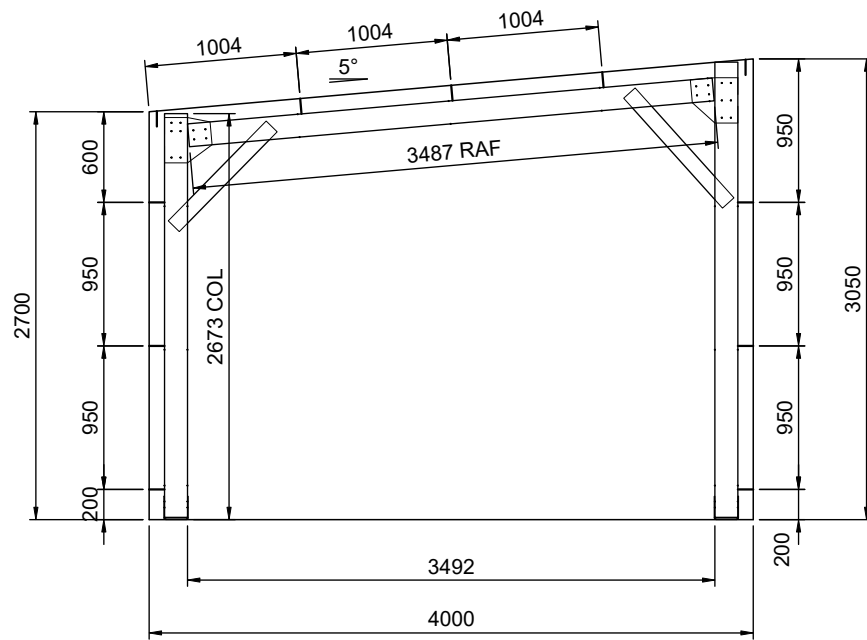

1 INTERNAL FRAMING ELEVATION
9 SCALE: 1:50 FRAME #2

MEMBER SCHEDULE			
COMPONENT		TYPE	
CLEAR SPAN PORTAL (FRAME 2)	MEMBER	RAFTER	Single C15019
		COLUMN	Single C15019
		APEX BRACE	-
		KNEE BRACE	Single C10010
	BASE CONNECTION	BRACKET TYPE	Base cleat bolt down bracket BC.150
	ANCHOR BOLTS	(2) Powers PTB-ETA1-PRO M12 x 135mm embedded 91mm	
ENDWALL PORTAL (FRAMES 1, 3)	MEMBER	RAFTER	Single C15019
		COLUMN	Single C15019
		APEX BRACE	-
		KNEE BRACE	Single C10010
	BASE CONNECTION	BRACKET TYPE	Angle base connection ABC.C150.60
	ANCHOR BOLTS	(2) Powers PTB-ETA1-PRO M12 x 135mm embedded 91mm	
ROOF PURLINS		MEMBER	Single Z10010 @ 1004mm centres
EAVE PURLIN		MEMBER	Single C10010
SIDEWALL GIRTS		MEMBER	Single Z10010 @ 950mm centres
ENDWALL GIRTS		MEMBER	Single Z10010 @ 950mm centres
OPENING (1)	MEMBER	JAMB	Single Z20015
		HEADER/SILL	Single C10012
	BASE CONNECTION	BRACKET TYPE	Angle base connection ABC.C200.110
	ANCHOR BOLTS	(2) Simpson Strong-Tie Screw Anchor THD10 x 80mm embedded 75mm	
OPENING (2)	MEMBER	JAMB	Single Unlipped 102 x 1.9 Cee
		HEADER/SILL	Single C10012
	BASE CONNECTION	BRACKET TYPE	Angle base connection ABC.SINGLE
	ANCHOR BOLTS	(1) Simpson Strong-Tie Screw Anchor THD10 x 80mm embedded 75mm	

REV	DATE	DESCRIPTION
A	25-03-2025	-



ANOTHER
COLD FORMED BUILDING
DESIGNED BY
ACT BUILDING SYSTEMS

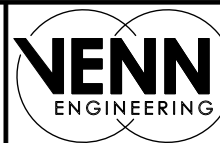

PO Box 3084
THIRROUL NSW 2515
sheds@venn.engineering
ABN 39 626 802 257

Signed *[Signature]* Date 25-03-2025
Grant J Wood MIEAust CPEng NER RPEQ
 Registered EA Chartered Professional Engineer (No. 2383009)
 Registered Professional Engineer QLD (No. 14384)
 Registered Civil Engineer Building Practitioner VIC (No. PE0002499)
 Registered Certifying Engineer (structural) NT (No. 306371ES)
 Building Services Provider (Engineer Civil) TAS (No. 699339425)

Customer Name: Luke Bailey
 Site Address: 9 Br Ted Magee Rd
 Collingwood Park,
 QLD, 4301

DATE 25-03-2025
 JOB NO. EALB99982966
 SHEET 9 of 9

Generic Temporary Bracing Information

The installation of temporary bracing is critical to avoid building collapse or damaging structural movement during construction. This collapse can occur with no notice and as such the installation of appropriate temporary bracing is critical to avoid damage, injury, and possible death. Determination, procurement, and correct installation of temporary bracing is the responsibility of the builder / primary contractor / installer.

Bracing Materials

The constructor / installer is to supply suitably sized materials for temporary bracing. These materials are generally capable of tension, but in some circumstances will need to be capable of tension and compression. Load rated ratchet strapping of an appropriate size can be used to temporarily 'x-brace' bays in both directions, until the final bracing systems are fully installed. This is especially critical for buildings where X Bracing is not required in the final structure due to the use of moment frames or diaphragm bracing.

Temporary Bracing Location

The location of Temporary bracing will depend on the installation method used. Installation should be completed in accordance with the Construction Package, Engineering Plans, and Instruction Manuals. If the Frame First Method (most common) is used, then the use of tension only bracing and creating temporarily braced bays as per Fig 1 and Fig 2. can be used. As a basic guide, a minimum of every 4th bay should have temporary bracing installed as per Fig 2.

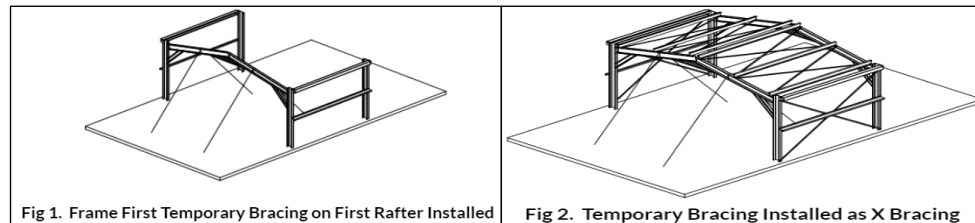

If the Tilt Up Method is used (where walls are constructed on the ground and then tilted into place), then the tops of columns are braced with a tension and compression brace in the same direction Fig 3. Then rafters and purlins can be installed with temporary bracing holding rafters in place (similar to Fig 1) until final bracing of diaphragm sheeting is installed.

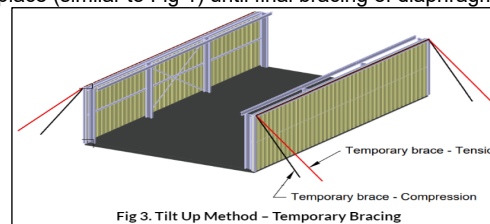

Typically, braces should be positioned diagonally across the structure from the top to the bottom, intersecting near the midpoint to provide stability, optimally at a 45-degree angle but no less than a 20-degree angle. The connection strength of temporary bracing is a critical consideration and these connections must be capable of resisting the potentially substantial temporary bracing loads – whether this connection point be to the building, the foundations or to the ground. Dependent upon building size this may include heavy angles and post installed concrete anchors. The temporary bracing methods used must be capable of fully stabilising the structure during the construction process.

Additional Temporary Bracing

The temporary bracing described is a minimum requirement for a standard-sized building in average conditions. Additional consideration should be given to larger building spans and/or challenging site conditions. There may also be an increased risk in relation to partially completed buildings and exposed sites. It is recommended that extra temporary bracing is utilized if moderate wind speeds are expected on site. Additional support elements, such as steel cables may need to be introduced that can be attached to the building's framework and anchored to the ground or other stable structures to provide extra stability. The frame should remain rigid throughout and such responsibility lies with the constructor. Buildings should not be left in a partially completed state longer than necessary.

Bracing Removal

The temporary bracing should not be removed until all purlins, girts and permanent cross bracing, diaphragm bracing or moment frames where used are installed. The temporary bracing is to remain in place where possible, until the roof and wall cladding is fully installed. If you need any further information regarding the installation of temporary bracing or are at all unsure of the necessary requirements for this specific building, there are guides available through various industry bodies:

<https://www.safeworkaustralia.gov.au/> 'Construction work – steel erection. Information sheet', 2016.

<https://www.steel.org.au/> 'Structural steelwork fabrication and erection code of practice', 2014.

<https://www.standards.org.au/> AS/NZS 5131:2016 'Structural steelwork – Fabrication and erection.

Support is also available at support@actbuildingsystems.com.

THE ABOVE INFORMATION REGARDING TEMPORARY BRACING DOES NOT FORM PART OF THE ENGINEERING CERTIFICATION FOR THIS DESIGN AND IS PROVIDED AS A GUIDE TO AID INSTALLATION ONLY.