

FRONT VIEW

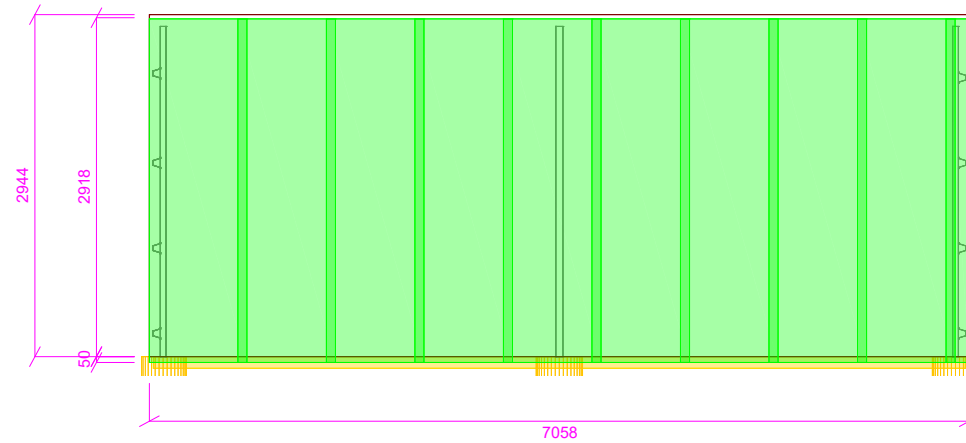

BACK VIEW

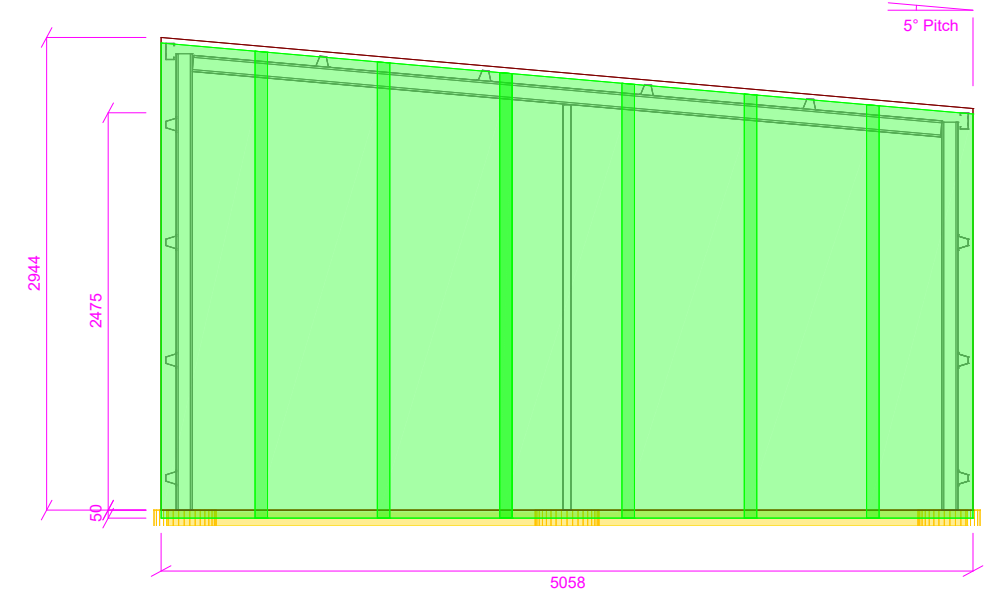

LEFT VIEW

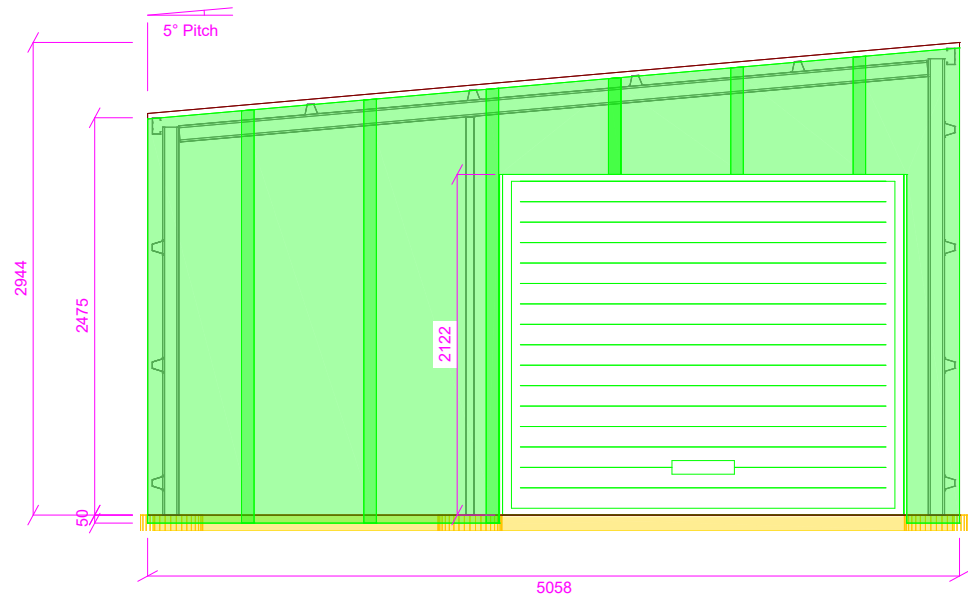

RIGHT VIEW

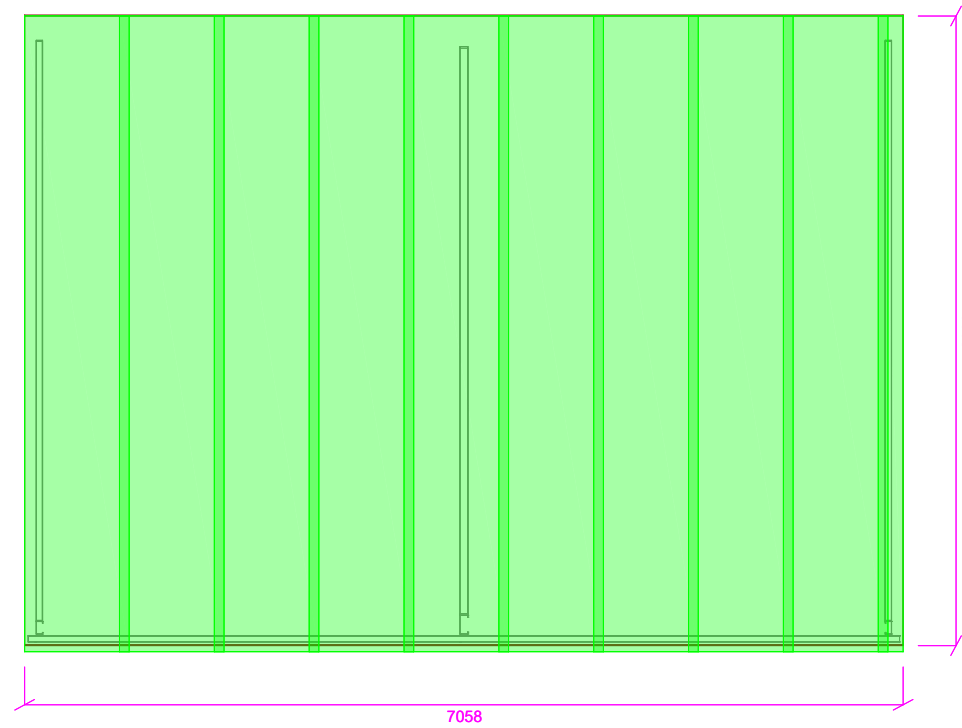

PLAN VIEW

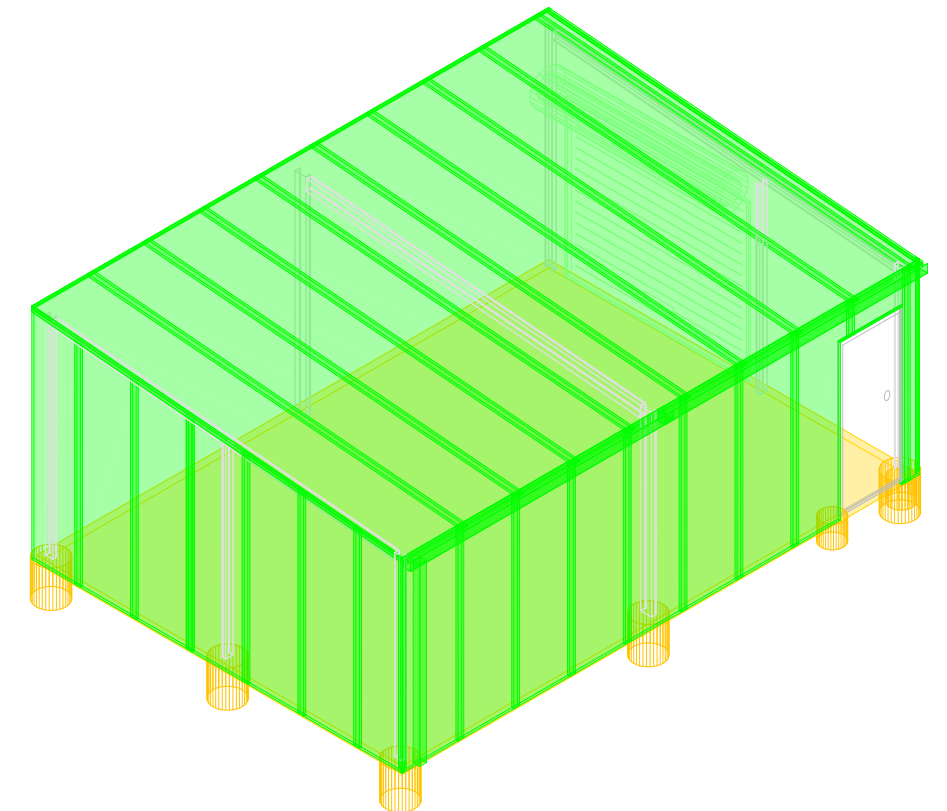

ISO FRONT LEFT VIEW

Elevation Multiview



Signed:	Drawing Number: 1 of 7
	Project No: AMS03_263306
	Revision: 4 - 20 Jun 2024
	8 Arthur St
	Naracoorte, SA 5271
	Scale: N/A

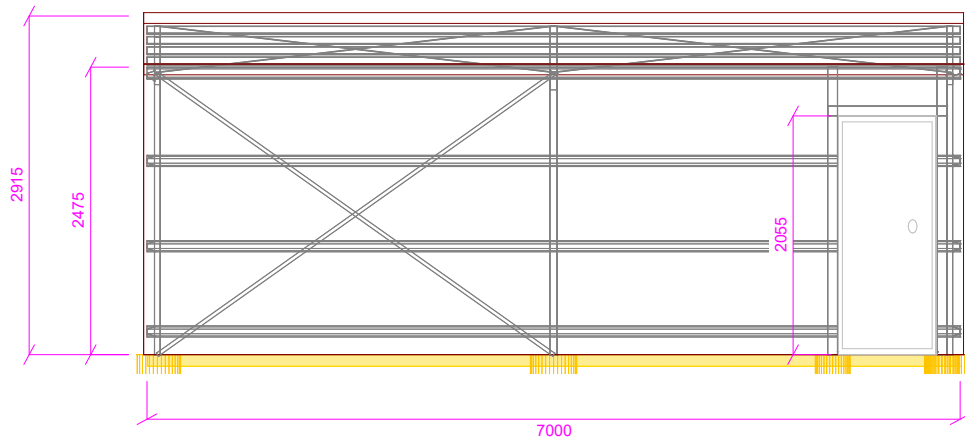

FRONT VIEW

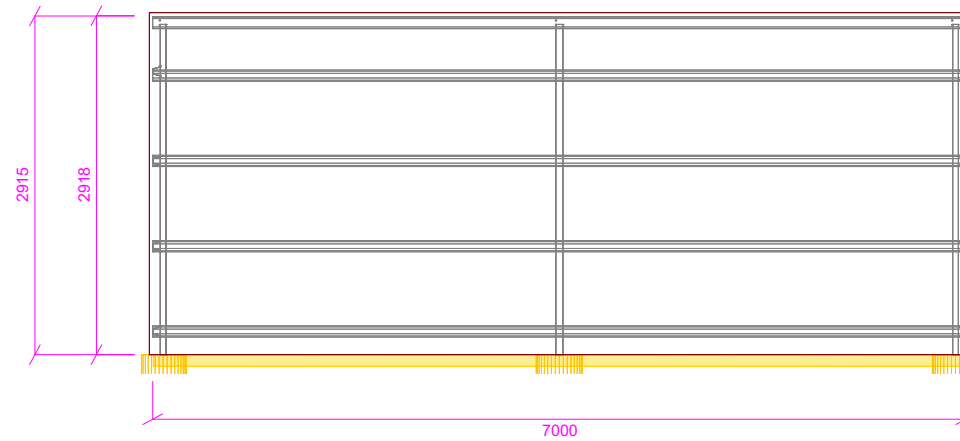

BACK VIEW

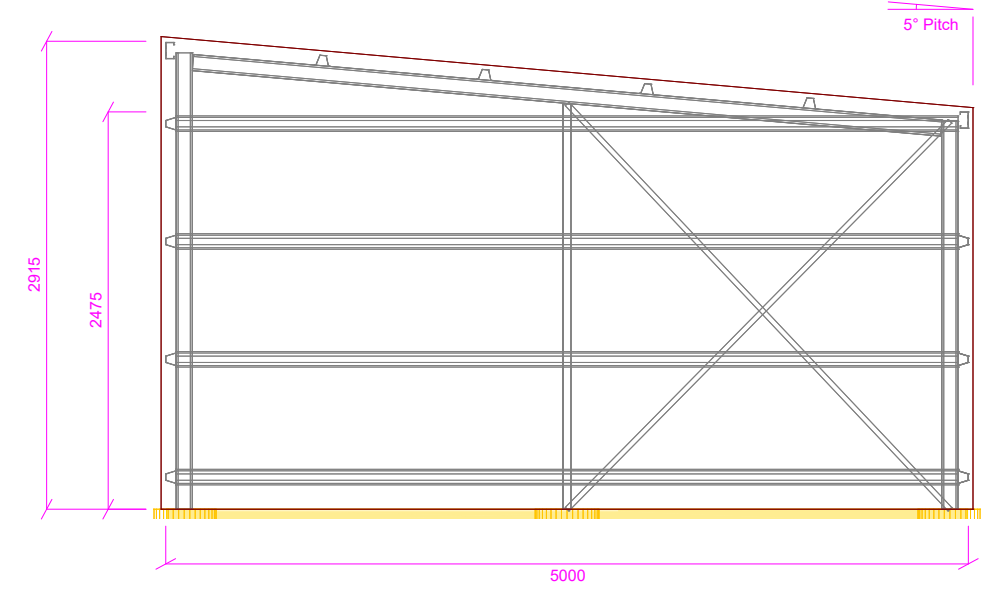

LEFT VIEW

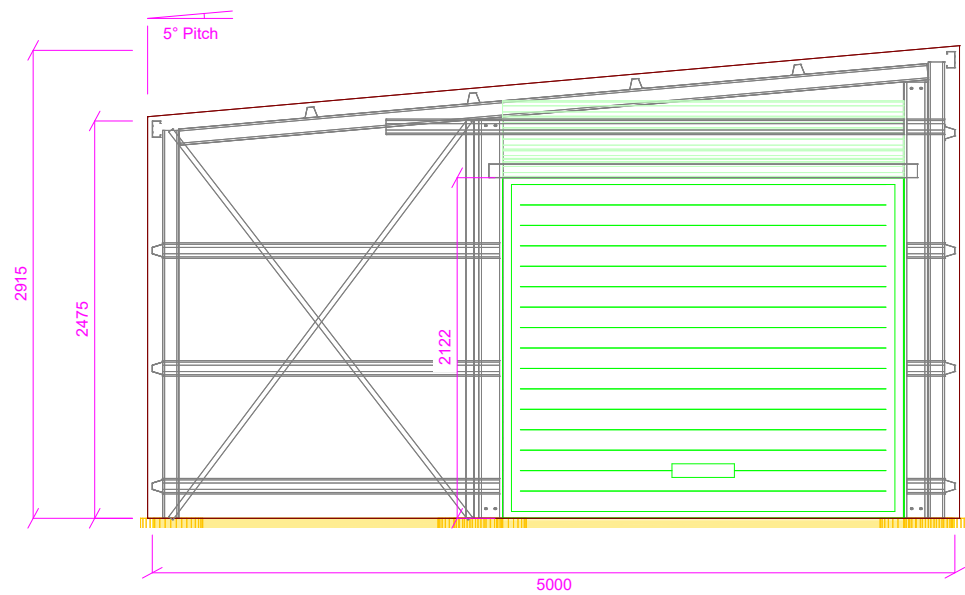

RIGHT VIEW

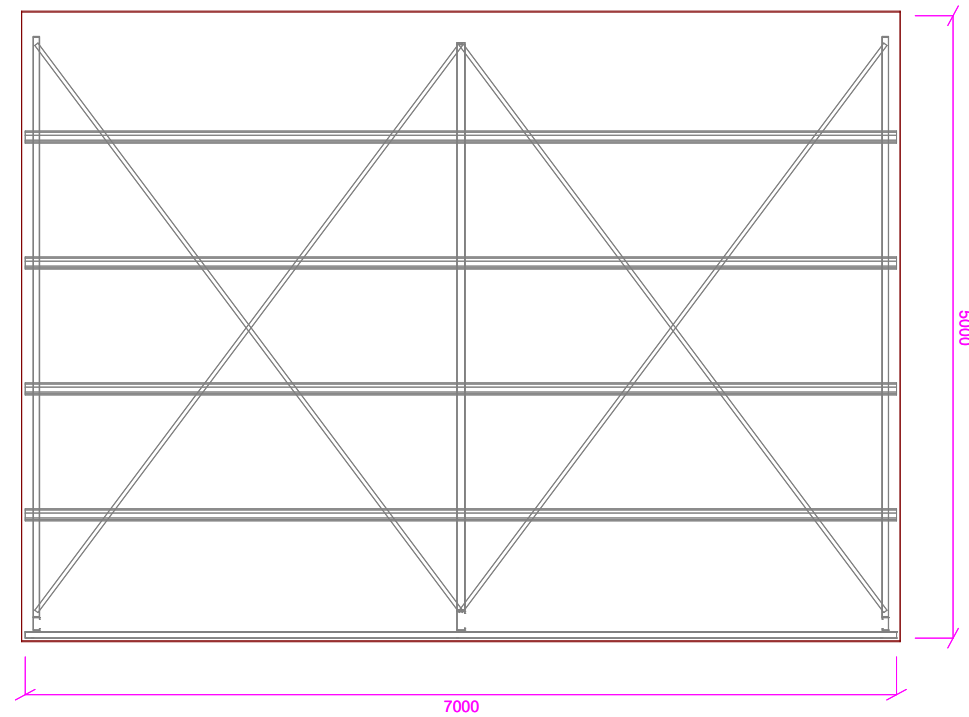

PLAN VIEW

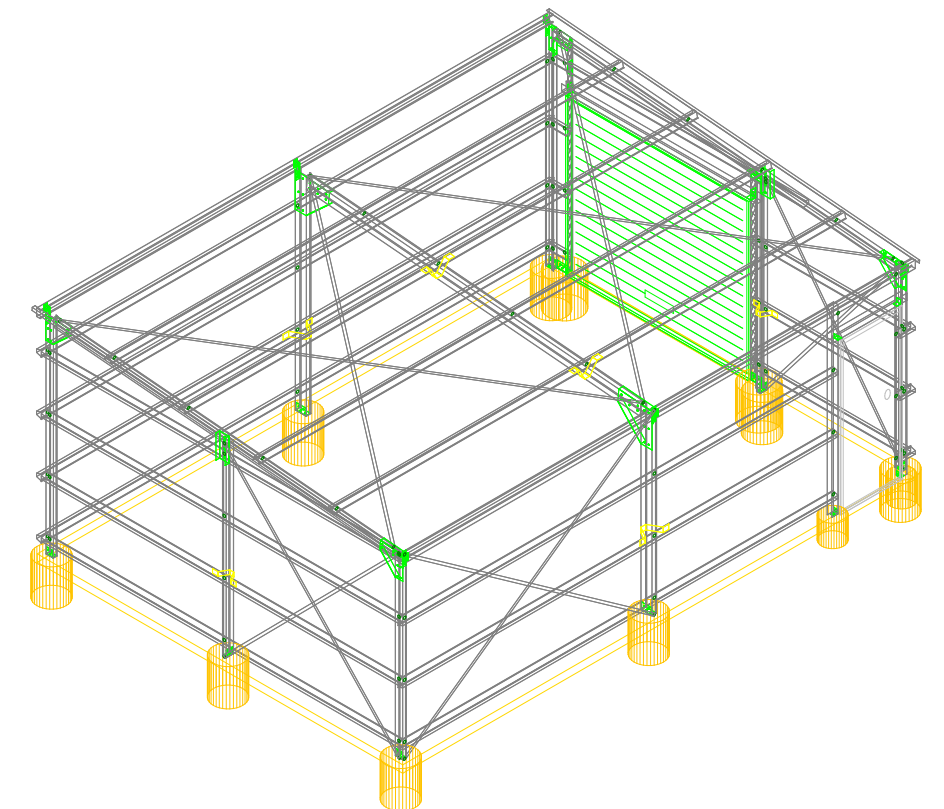

ISO FRONT LEFT VIEW

Assembly Multiview



Signed:	Drawing Number: 2 of 7
	Project No: AMS03_263306
	Revision: 4 - 20 Jun 2024
	8 Arthur St Naracoorte, SA 5271
	Scale: N/A

NOTE: Construction drawings must be used in conjunction with the Shed Plus Installation Manual.

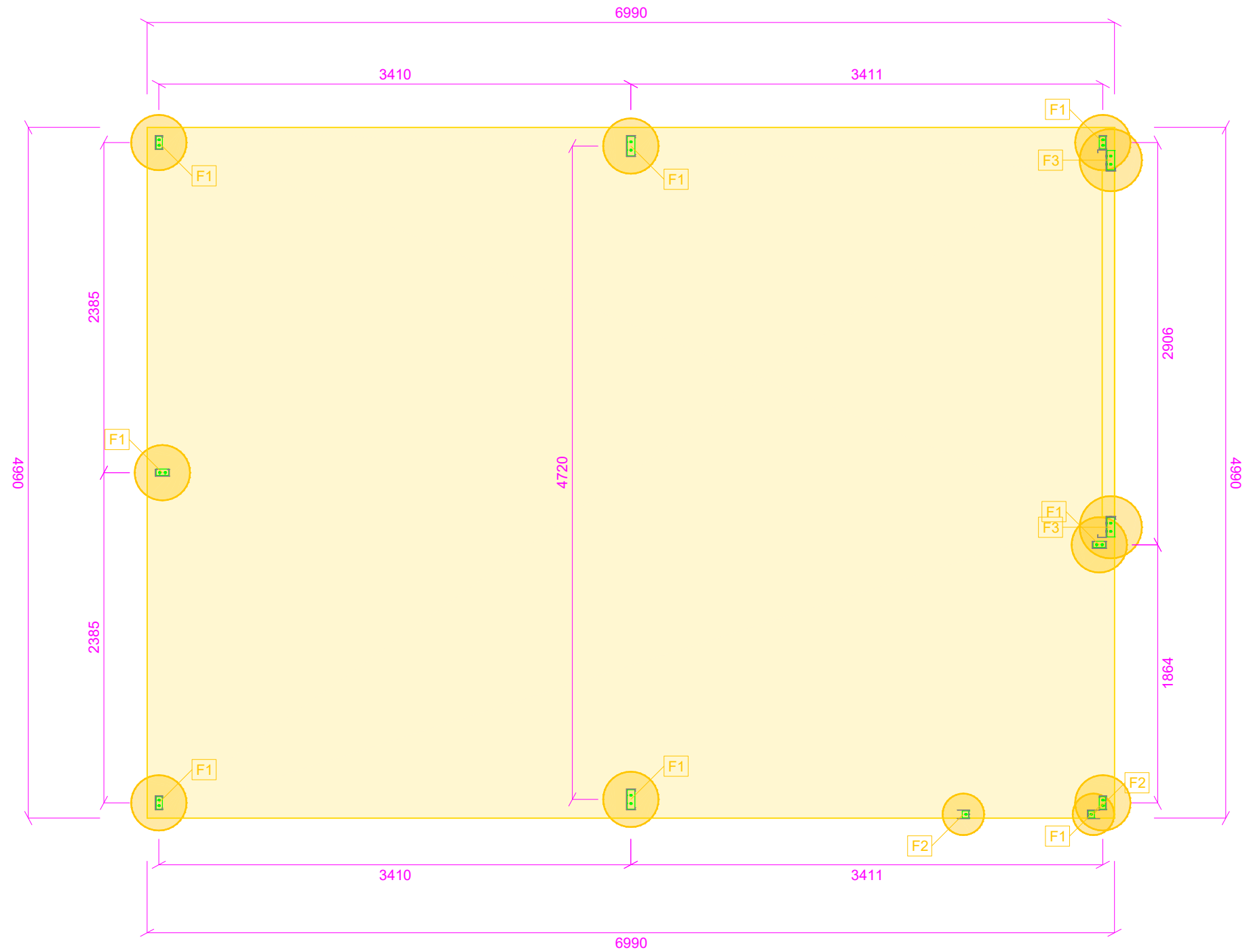

ALL MEMBER DIMENSIONS FROM
> MEMBER CENTRE <

Foundation Columns Plan View



Signed:

Drawing Number: 3 of 7
Project No: AMS03_263306
Revision: 4 - 20 Jun 2024
8 Arthur St
Naracoorte, SA 5271
Scale: 1 : 41 @ A3

NOTE: Construction drawings must be used in conjunction with the Shed Plus Installation Manual.

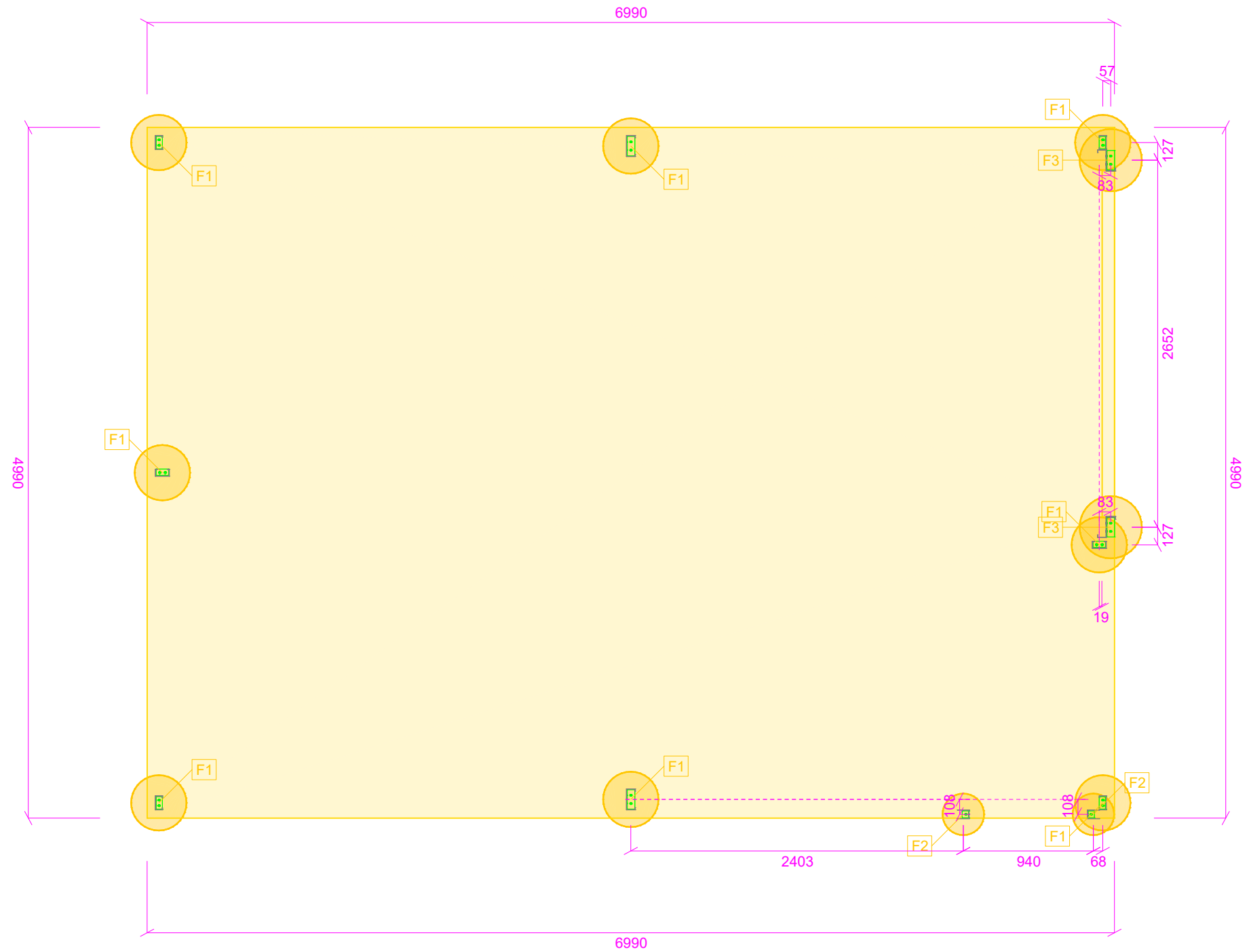

ALL MEMBER DIMENSIONS FROM
> MEMBER CENTRE <

Foundation Mullions Plan View



Signed:

Drawing Number: 4 of 7
Project No: AMS03_263306
Revision: 4 - 20 Jun 2024
8 Arthur St
Naracoorte, SA 5271
Scale: 1 : 41 @ A3

FOOTING NOTES

1. Footing sizes shown on the drawings are the minimum required for structural loads.
2. Where a shed's footings are required to comply with AS 2870 - Residential slabs & footings, the minimum footing depth (mm) shall be taken as the greater of the footing depths shown on the drawings or the footing depths according to the site classification listed below:
 Class A & S: 400
 Class M: 500
 Class M-D: 800
 Class H1: 1000
 Other Classes shall be determined by a geotechnical report.
3. Construction drawings must be used in conjunction with the Shed Plus Installation Manual.

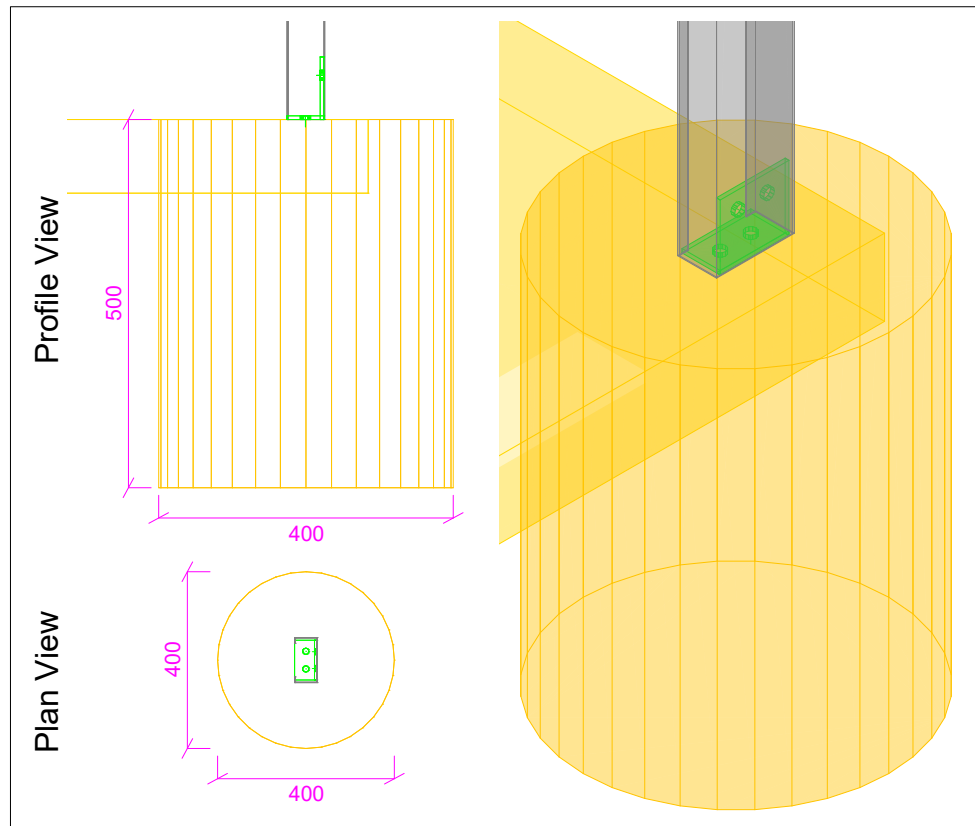

Footing: F1 (x8)

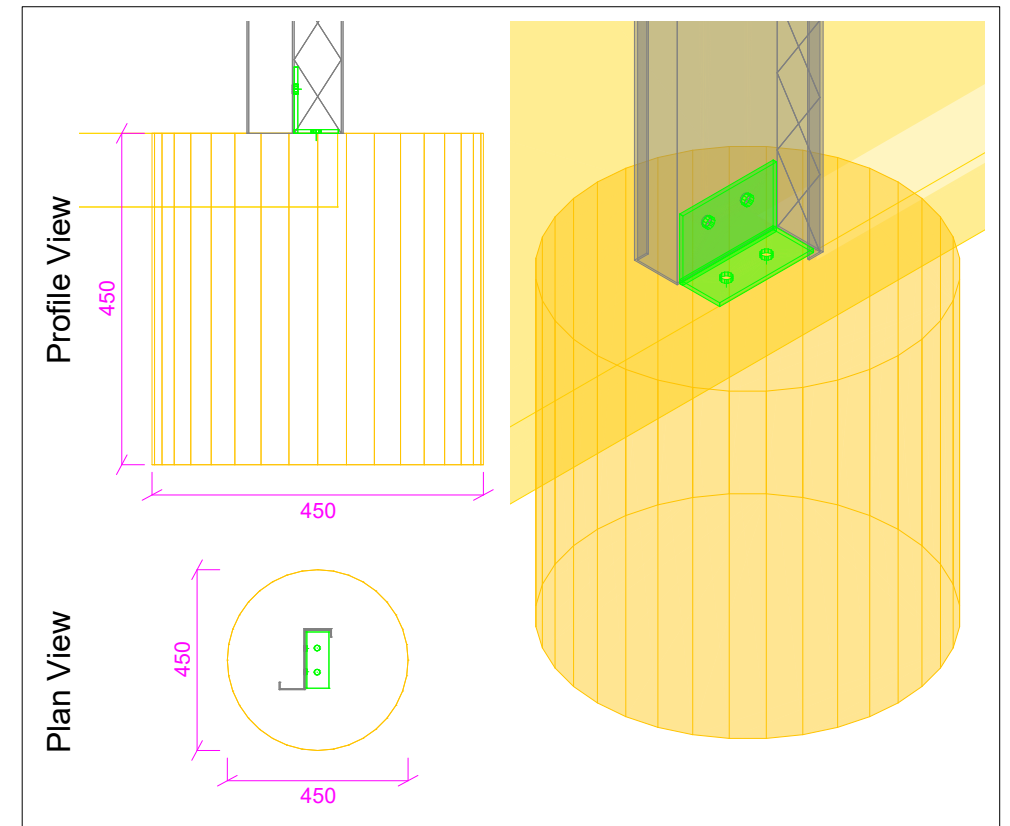

Footing: F3 (x2)

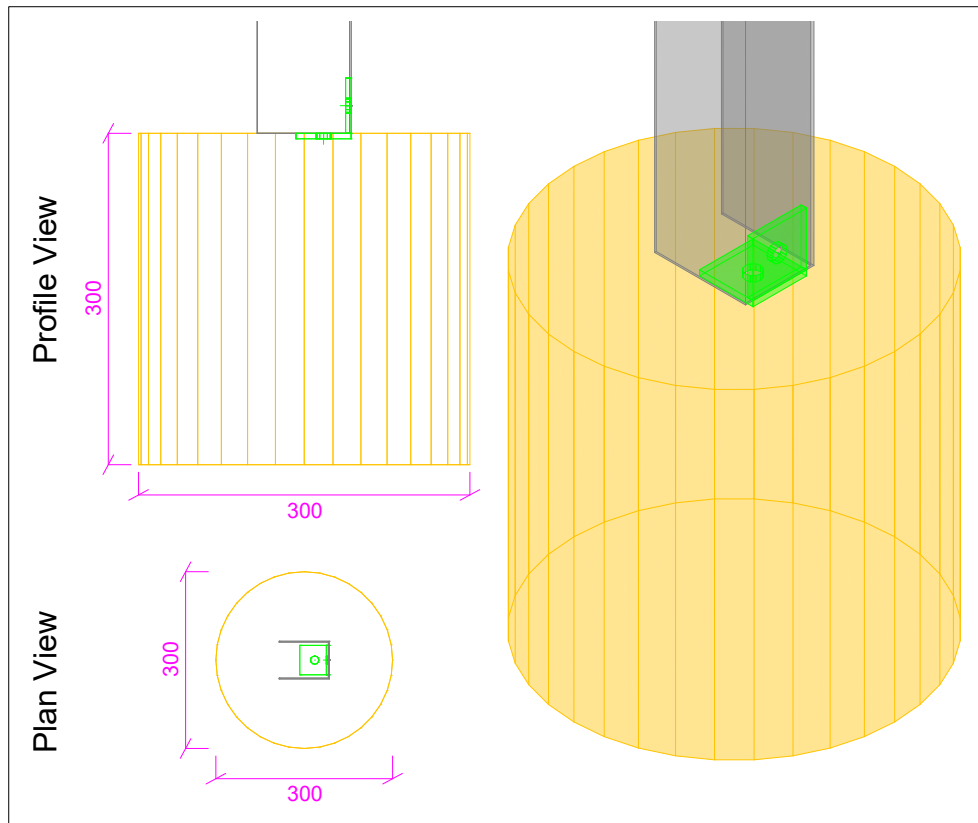

Footing: F2 (x2)

Footing Index Drawings



Signed:	Drawing Number: 5 of 7
	Project No: AMS03_263306
	Revision: 4 - 20 Jun 2024
	8 Arthur St
	Naracoorte, SA 5271
	Scale: N/A

TYPICAL FOOTING CONSTRUCTION NOTES AND DETAILS

Bored Footing

Side View

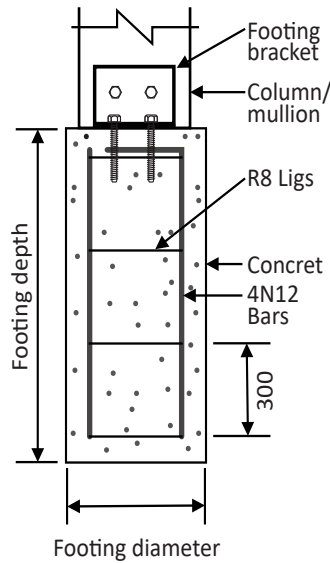

Plan View

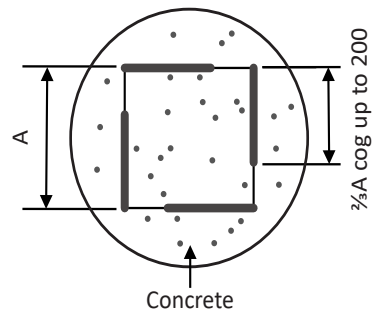

ISO View

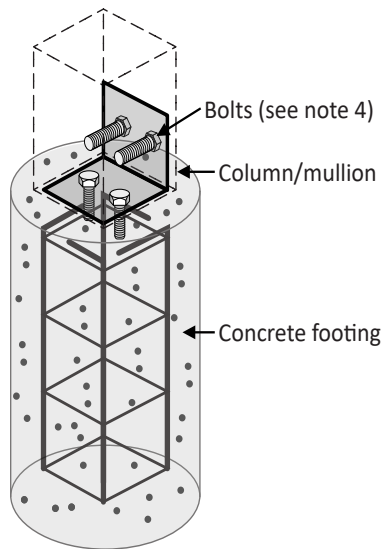

Bored Footing with Slab

Side View

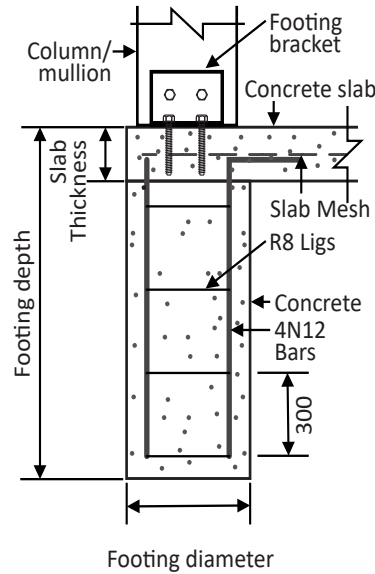

Plan View

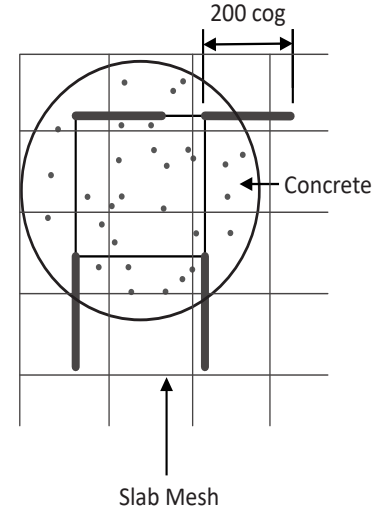

ISO View

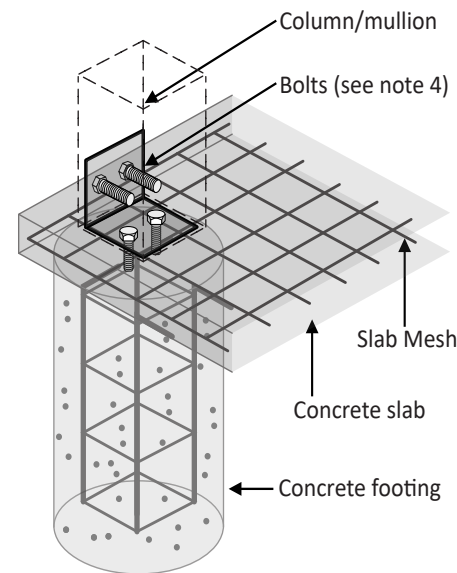

Square Footing

Side View

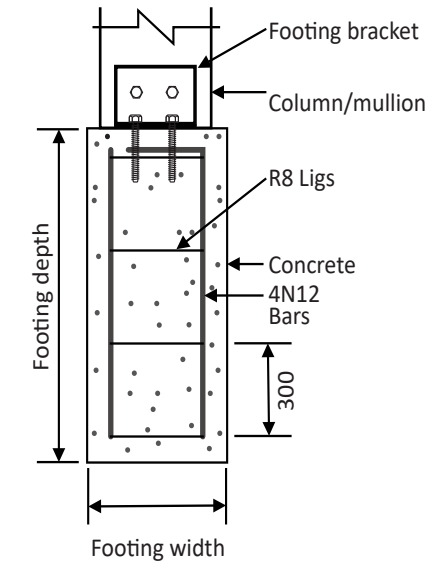

Plan View

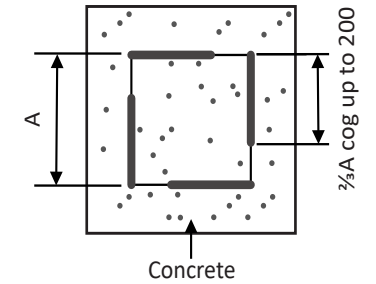

ISO View

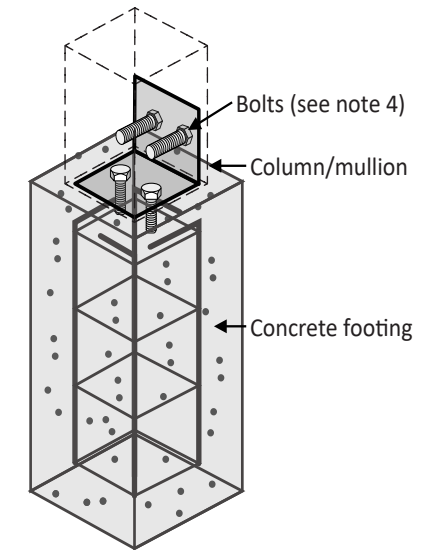

Notes

1. Longitudinal reinforcement shall be 4N12 with cogs at top. R8 ligs at 300 cts. 100 minimum cover.
2. For footing bracket, refer to connection drawing for column fixing detail and connection configuration.
3. All concrete work to be carried out in accordance with AS3600 & AS2870.
4. Anchor quantity is for indicative purpose only.
5. All reinforcements shall conform with AS4671-2001.
6. Care should be taken to ensure that bolts are anchored below without shifting any reinforcement fabric or bars.

7. The typical footing construction notes and details must be read in conjunction with the footing notes. The footings and slab must be constructed with concrete edge beams, internal beams or edge thickening as required.
8. The details are not applicable for sheds supported by raft slab only (i.e. slab with integrated beams).
9. Min. concrete grade for Bored and Square Footing shall be N25. Min. concrete grade for slab shall be N20, refer relevant slab notes and details for more information.
10. Footing shall be founded in natural undisturbed soil with min. 100kpa allowable bearing capacity.

Footing Index Drawings



Signed:

Drawing Number: 6 of 7
 Project No: AMS03_263306
 Revision: 4 - 20 Jun 2024
 8 Arthur St
 Naracoorte, SA 5271
 Scale: N/A

NOTE: Construction drawings must be used in conjunction with the Shed Plus Installation Manual.
 NOTE: Slab edge thickening/s not shown for clarity. Slab Drawings must be read in conjunction with Footing Notes and Details - Industrial Slab, as shown in the last two drawing pages.

OPENING REBATES

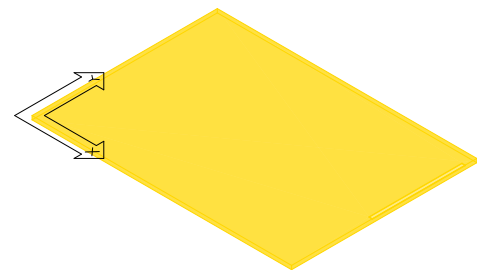
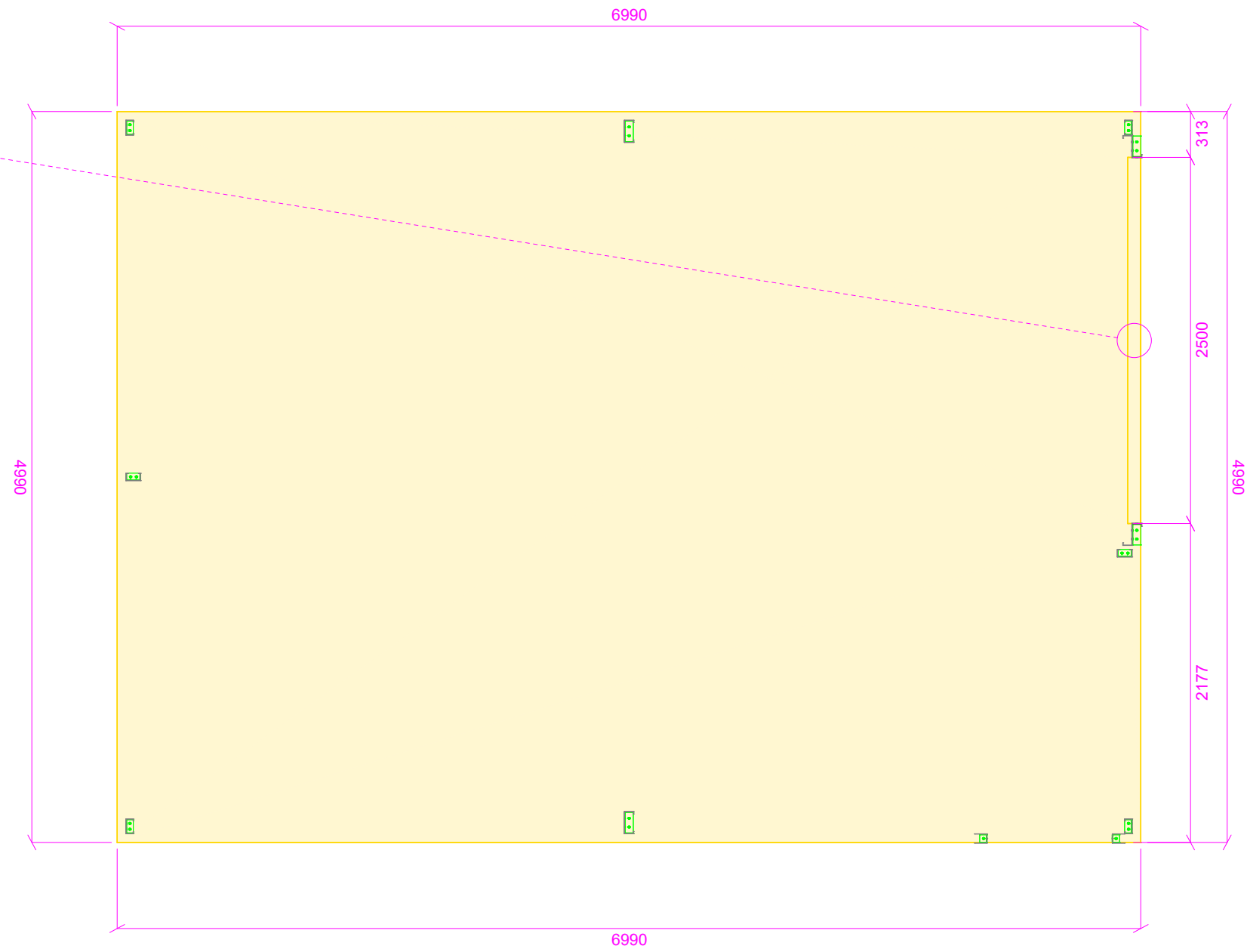
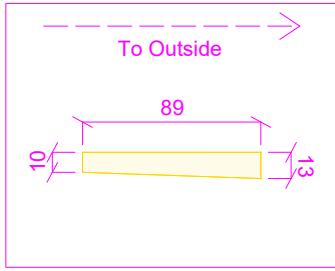

All Slabs Plan View

All Slabs



Signed:

Drawing Number: 7 of 7
Project No: AMS03_263306
Revision: 4 - 20 Jun 2024
8 Arthur St
Naracoorte, SA 5271
Scale: 1 : 44 @ A3