

GENERAL NOTES

These documents show the general arrangement of the building and include some items not supplied (refer to the quotation for nomination of all items to be provided). All items not nominated therein shall be supplied and installed by others.

The plans provided here are the latest at the time of print. Earlier plans provided may have become outdated due to engineering changes and should not be used. The plans and drawings are extensive and give all the information needed for a competent person to erect the building. The building is not designed to stand up by itself when it is partially complete. Consequently, construction bracing is critical during erection.

The owner has been requested to check off the BOM after the building delivery. You should check that you are able to locate all materials nominated in the BOM. You should also confirm that the length and size (including thickness), nominated in the BOM is what has been provided. Any missing items are the responsibility of the client once correct delivery has been confirmed as per Terms and Conditions of Sale.

DESIGN CRITERIA

These building plans have been prepared to comply with the standards nominated in the engineer's letter. All plans are not to Scale.

ADDITIONAL DOCUMENTATION TO BE SUPPLIED BY PURCHASER/OWNER

The Purchaser/Owner is responsible for:

- *Provision of Soils Report for the site and in the building area on which the building is to be erected
- *Site Plan and Drainage Plans
- *Any other plans not covered by these engineering plans requested by the local Council or the authority
- *Nomination of termite risk management procedures to be undertaken in compliance with NCC Volume 2 Part 3.1.4
- * Compliance with specific site constraints e.g.:
 - local estate covenants, building envelopes, plan of development etc.
 - bushfire management requirements(NCC Volume 2 Part 3.10)
- *Energy efficiency assessment and compliance with all conditions thereof

RAINWATER AND DRAINAGE

All Rainwater and drainage designs are the responsibility of the purchaser/owner. Residential gutters and downpipes where supplied are based on average rainfall for the state and may not be sufficient for your building size or usage. Please speak to your building designer or contractor to ensure gutters are fit for purpose.

BUILDING CONSTRUCTION REQUIREMENTS

The Builder and Purchaser are to ensure that all construction is carried out in accordance with the Plans, the Construction Manual and the Bill of Materials (BOM).

It is the responsibility of the builder to ensure that they are familiar with the operational risks and their obligations in carrying out construction work.

The builder must ensure that they have an appropriate Health & Safety Plan (The Plan) compliant with and as required by their local, state and federal regulations. The Plan will need to take into account the site conditions, the size of the building and the experience of the construction personnel. The Plan will, most likely, differ for each project.

The builder must ensure that The Plan is adhered to. Particular attention should be paid to the requirements to ensure that any person working at heights are properly trained and following the requirements as set out by The Plan.

It is recommended that you check with the appropriate authority in your area as to your responsibilities.

TEMPORARY SUPPORT, LIFTING AND SHORING

The design of temporary propping shoring, lifting and support during construction has not been undertaken and is not included in our engagement. This work is the responsibility of the Contractor undertaking the construction of the building.

SLAB DETAILS - GENERAL

Piers

- * The minimum size of Piers under the columns and End Wall Mullions are nominated on the Material Specifications Plan. When the slab and piers are poured as one pour, the depth of the pier is to the top of the slab.
- * Pier Reinforcement: for any piers over 1100mm, deformed bar to within 100mm of base and minimum 75mm top cover. Minimum side cover 75mm, maximum 100mm. Rod to be caged horizontally at least twice and at a maximum of 300mm spacing. Tie with a minimum of 6mm diameter cage tie. Where pier diameter is less than 450mm diameter, use 4 N12. For diameters equal to and over 450mm, use 4 N16.
- * Where columns or end wall mullions have been removed, piers are not required.
- * End wall mullion spacing may move due to location of openings or doors. Check layout and component position plan, and relocate piers as required.
- * The Slab Plan indicates those parts of the slab which are 50mm below main slab/piers.

Concrete Slab

- * Refer to separate sheet titled Slab Notes.
- * Refer to connection details.

For Class A or S Sites

- * Slab thickness to be a minimum of 100mm. Slabs under 18m in length SL 72 mesh. Slabs upto 25m in length SL 82 mesh.
- * Perimeter Beam - Depth of 300mm ; Bottom reinforcement of 3-L8TM
- * Internal Beam - Not Required

For Class M Sites

- * Slab thickness to be a minimum of 100mm. Slabs under 18m in length SL 72 mesh. Slabs upto 25m in length SL 82 mesh.
- * Perimeter Beam - Depth of 300mm ; Bottom reinforcement of 3-L8TM
- * Internal Beam - Depth of 300mm ; Bottom reinforcement of 3-L8TM ;Maximum spacing of 4m on the corners and then a maximum of 6.0m

For Class H1 Sites

- * Slab thickness to be a minimum of 100mm. Slabs under 18m in length SL 72 mesh. Slabs upto 25m in length SL 82 mesh.
- * Perimeter Beam - Depth of 400mm ; Bottom reinforcement of 3-L11TM
- * Internal Beam - Depth of 400mm ; Bottom reinforcement of 3-L11TM ;Maximum spacing of 4m on the corners and then a maximum of 5.0m

For Class H2 sites

- * Slab thickness to be a minimum of 100mm. Slabs under 18m in length SL 72 mesh. Slabs upto 25m in length SL 82 mesh.
- * Perimeter Beam - Depth of 550mm ; Bottom reinforcement of 3-L11TM
- * Internal Beam - Depth of 550mm ; Bottom reinforcement of 3-L11TM ;Maximum spacing of 4.0m.

SHEETED PORTALS AND MULLIONS

All end wall mullions provide critical support to portal frames and cannot be repositioned or removed under any circumstances without engineering approval.

BRACING NOTES

- * Refer to Connection Details.
- * All Cross Bracing is achieved with 1.2mm Strap G450.
- * Cross bracing is to be fixed taut and secured with 14.20 x 22 frame screws at each end, quantity as per connection details.
- * Fly bracing to be fixed to the purlins/girts on all mid portal rafters, columns and end wall mullions. Fly bracing is to be fitted to every second purlin/girt, or, on every one, where the spacing between fly braces would exceed the maximum specified below for the relevant column/rafter size:
 - C150 - maximum 1800mm spacing
 - C200, C250 - maximum 2200mm spacing
 - C300 - maximum 2800mm spacing
 - C350 - maximum 2800mm spacing
 - C400 - maximum 2800mm spacing

Initial measurement is from the haunch of the column/rafter, and from the rafter for any end wall mullions.

* Where windows/GSD are placed in any bay where cross bracing is shown, then

- this can be replaced by moving the bracing to another bay OR
- due to the bracing provided by the window jambs, where space permits, bracing should be placed under and over the window.

* All bracing strap ends to be located as close as practical to structural member's (columns, rafters, mullions) centerline.

BOLTS

Revision	Date	Initial			General Notes	Seller: Steel Buildings Head Office Name: Wide Span Sheds Pty Ltd Phone: 07 5657 8888 Fax: 1800 427 400 Email: engineering@steelx.com.au	Apex Engineering Group PTY LTD ACN 632 588 562 MIE Aust. (Registered NER Structural) 5276680 QLD : RPEQ No. 24223; TAS : 185770492; VIC : PE0003848; N.T : 303557ES; Practising Professional Structural & Civil Engineers Signature:  John Ronaldson Date: 29/11/23
			Purchaser Name: Jeannie Lewis				
			Site Address: 22 Macquarie Street Neville NSW 2799 Australia				
			Drawing # ASBA234031 - 2	Print Date: 29/11/2023			
					Page 1 of 2 ©Copyright Steelx IP Pty Ltd		

- * Unless otherwise nominated, all bolts are grade 4.6
- * All tensioned bolts shall be tensioned using the part turn method (refer to AS4100). For the erector, full details are in the construction manual.

OTHER MATERIALS NOTES

- * All Sheeting, Flashing and framing screws are Climaseal 4.
- * All purlin material has Z350 zinc coating with minimum strength of 450MPa.

INTERNAL WALL AND FIXING DETAILS (BY OTHERS)

The building has not been designed for the deflection limitations of plasterboard. Although plasterboard may be used as internal wall and roof linings, excessive cracking is likely to occur should the plasterboard joints be set. When plasterboard is used, dado rails or expansion beads etc. should be considered as an alternative to setting the joints. If it is desired to line any part of the building with plasterboard, then the builder should consult their plasterboard supplier for expert advice. A suitable internal lining would be a plywood wall panel, eg. Rezilience 2.7mm Interior Wall Paneling or similar. Any linings and the fixings for any linings are to be provided by others. The selected wall and ceiling panel should have a weight of no more than 10kg/m2. Refer to manufacturer's fixing specifications for your chosen product and provide additional fixings as required.

BUILDING CONSTRUCTION REQUIREMENTS

The Purchaser/Owner is to be ensured that all building construction complies with:

Workplace Health and Safety requirements for the particular State or Territory Building Code of Australia (current edition at time of approval) and all subsequent amendments and standards contained therein, including:

- All glazing to comply with NCC Volume 2 Part 3.6
- Smoke alarms (consumer mains power) to be installed in accordance with NCC Volume 2 Part 3.7.5.2
- Provide lift-off hinges to doors of enclosed sanitary compartments in accordance with NCC Volume 2 Part 3.8.3.3
- All stairs and balustrades to comply with NCC Volume 2 Part 3.9. Stairs are provided by owner and designed by others.

MOISTURE MANAGEMENT

It is the responsibility of the Builder to ensure appropriate Moisture Management is provided during wall construction through effective use of flashings, sealants and vapour permeable membrane such as vapour permeable sarking, building wraps, vapour retarders and damp-proof course. Before installing cladding, all wall openings, penetrations, intersections, connections, window sills, head and jambs must incorporate appropriate flashing and water proofing materials. Components and their installation that are used to manage moisture in wall construction must, at a minimum, comply with the requirements of relevant standards, building codes and manufacturer's specifications.

Revision	Date	Initial	Purchaser Name: Jeannie Lewis		General Notes Page 2 of 2 ©Copyright Steelx IP Pty Ltd	Seller: Steel Buildings Head Office Name: Wide Span Sheds Pty Ltd Phone: 07 5657 8888 Fax: 1800 427 400 Email: engineering@steelx.com.au	Apex Engineering Group PTY LTD ACN 632 588 562 MIE Aust. (Registered NER Structural) 5276680 QLD : RPEQ No. 24223; TAS : 185770492; VIC : PE0003848; N.T : 303557ES; Practising Professional Structural & Civil Engineers Signature:  John Ronaldson Date: 29/11/23
			Site Address: 22 Macquarie Street Neville NSW 2799 Australia				
			Drawing # ASBA234031 - 2	Print Date: 29/11/2023			

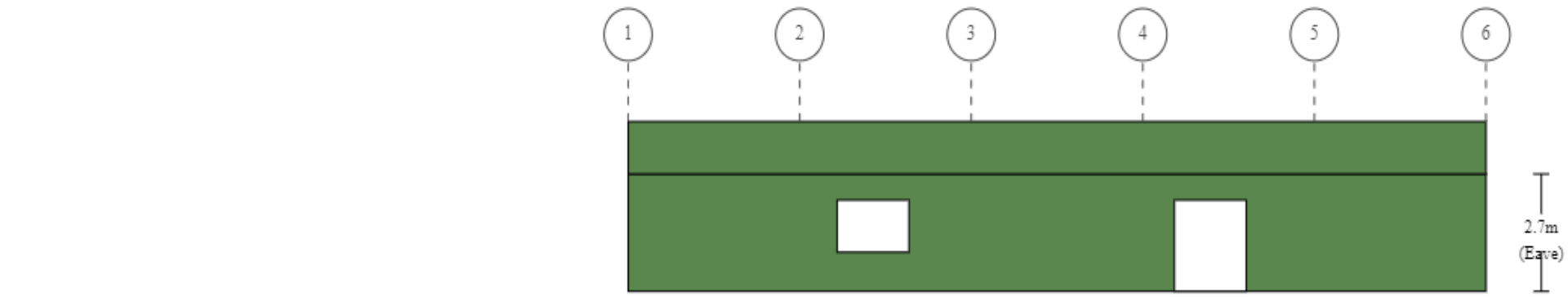

Left Side

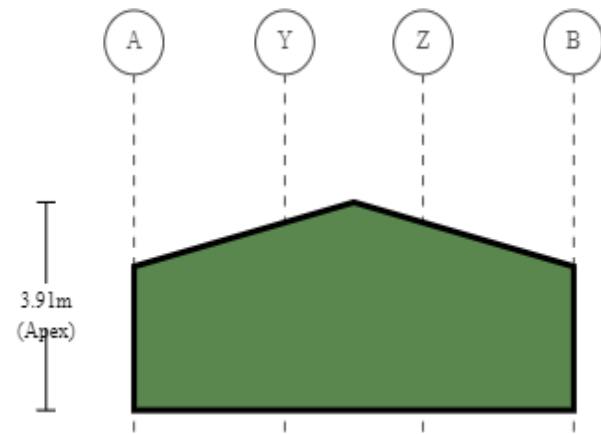

Left End

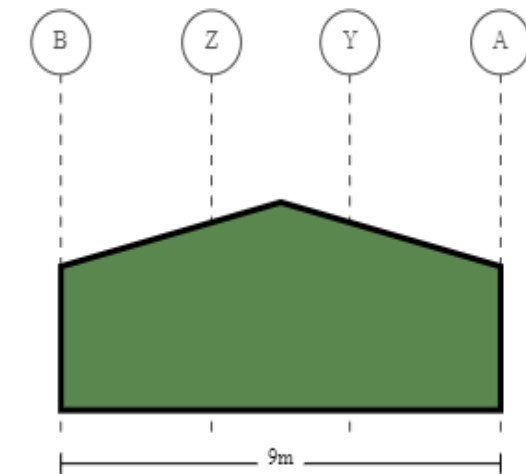
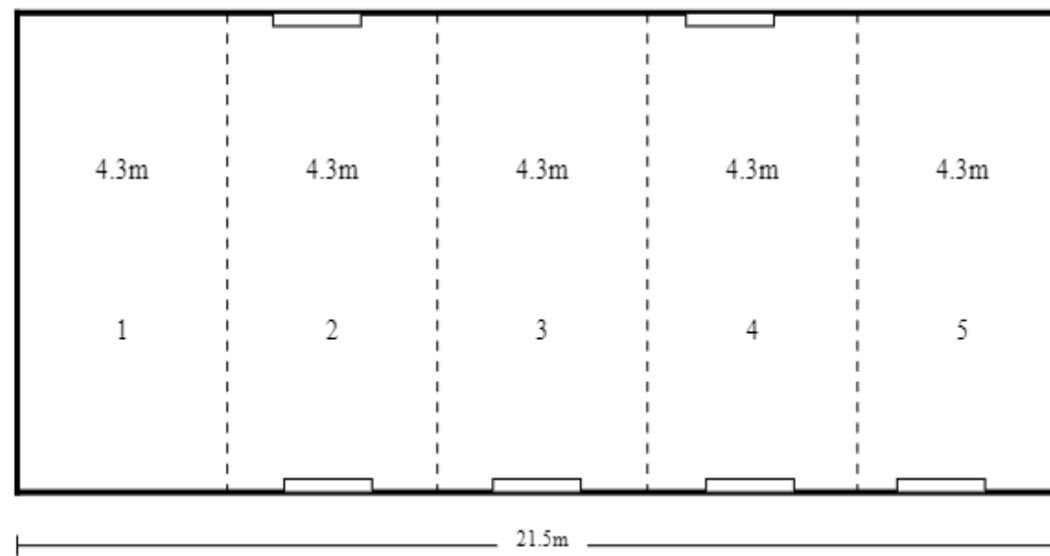

Right End



Right Side

Purchaser Name: Jeannie Lewis

Site Address: 22 Macquarie Street Neville NSW 2799 Australia

Drawing # ASBA234031 - 3

Print Date: 29/11/23

Layout
Not to Scale
© Copyright Steelx IP Pty Ltd

Seller: Steel Buildings Head Office
Wide Span Sheds Pty Ltd
Phone: 07 5657 8888
Fax: 1800 427 400
Email: engineering@steelx.com.au

Apex Engineering Group PTY LTD
ACN 632 588 562
ME Aust. (Registered NER Structural) 5276680
QLD : RPEQ No. 24223; TAS : 185770492; VIC : PE0003848; N.T : 303557ES;
Practising Professional Structural & Civil Engineers

Signature: 

John Ronaldson

Date: 29/11/23

MATERIAL SPECIFICATIONS

For further information regarding the tabulated values shown, refer to the General Notes

Building Dimensions

Categories	Span	Length	Pitch	Height	Grid(s)	Portal(s)
Main Building	9	21.5	15	2.7	A - B	1 - 6

Portal Frame Elements

Grid / Portal Number		1	2	3	4	5	6
Columns	A	C15019	C20024	C20024	C20024	C20024	C15019
	B	C15019	C20024	C20024	C20024	C20024	C15019
Rafters	A - Apex	C15019	C20024	C20024	C20024	C20024	C15019
	Apex - B	C15019	C20024	C20024	C20024	C20024	C15019
End Wall Mullions	Y	C15012	-	-	-	-	C15012
	Z	C15012	-	-	-	-	C15012
Apex Braces	Apex	-	C15019 @ 2.7m	C15019 @ 2.7m	C15019 @ 2.7m	C15019 @ 2.7m	-

Bay Section Elements

Grid / Bay Number		1	2	3	4	5	Maximum
Bay Widths		4.3	4.3	4.3	4.3	4.3	
Roof Purlins (refer to Purlin And Girt Plan)		Z100	Z100	Z100	Z100	Z100	
Roof Purlin Spacing (End)	A - Apex	0.892	0.892	0.892	0.892	0.892	0.900
	Apex - B	0.892	0.892	0.892	0.892	0.892	0.900
Roof Purlin Spacing (Internal Spans)	A - Apex	0.892	0.892	0.892	0.892	0.892	1.200
	Apex - B	0.892	0.892	0.892	0.892	0.892	1.200
Eave Purlin	A	XC15012	XC15012	XC15012	XC15012	XC15012	
	B	XC15012	XC15012	XC15012	XC15012	XC15012	
Side Girts (refer to Purlin And Girt Plan)		Z100	Z100	Z100	Z100	Z100	
Side Girts Spacing (End)	A	1.235	1.235	1.235	1.235	1.235	1.700
	B	1.235	1.235	1.235	1.235	1.235	1.700
Side Girts Spacing (Internal)	A	1.235	1.235	1.235	1.235	1.235	1.700
	B	1.235	1.235	1.235	1.235	1.235	1.700

End Bay Section Elements

Grid / Portal Number		1	6	Maximum
End Girts (refer to Purlin And Girt Plan)		Z100	Z100	
End Girts Spacing (End)	A - Y	1.235	1.235	1.700
	Y - Z	1.235	1.235	1.700
	Z - B	1.235	1.235	1.700
End Girts Spacing (Internal)	A - Y	1.235	1.235	1.700
	Y - Z	1.235	1.235	1.700
	Z - B	1.235	1.235	1.700

Cladding Elements

Category	Colour	Product
Roof Sheeting	Paperbark	CORODEK® 0.42 BMT (0.47TCT)
Roof Flashings	COLORBOND® steel	BlueScope 0.55 BMT
Wall Sheeting	Paperbark	CORODEK® 0.42 BMT (0.47TCT)
Wall Flashing	COLORBOND® steel	BlueScope 0.55 BMT

Pier Sizes

Adhesion (kPa)	Soil Description	Diameter (m)	Depth (m) - with Slab	
			BP1	BP2
0	Sandy Soil	0.3	1.1	-
		0.45	0.7	1.1
		0.6	0.45	0.8

Revision	Date	Initial			Specification Sheet	Seller: Steel Buildings Head Office Name: Wide Span Sheds Pty Ltd Phone: 07 5657 8888 Fax: 1800 427 400 Email: engineering@steelx.com.au	Apex Engineering Group PTY LTD ACN 632 588 562 MIE Aust. (Registered NER Structural) 5276680 QLD : RPEQ No. 24223; TAS : 185770492; VIC : PE0003848; N.T : 303557ES; Practising Professional Structural & Civil Engineers
			Purchaser Name: Jeannie Lewis				
			Site Address: 22 Macquarie Street Neville NSW 2799 Australia				
			Drawing # ASBA234031 - 4	Print Date: 29/11/2023			
					Page 1 of 2		Signature:  John Ronaldson Date: 29/11/23

MATERIAL SPECIFICATIONS

For further information regarding the tabulated values shown, refer to the General Notes

Pier Sizes (Continue)

Adhesion (kPa)	Soil Description	Diameter (m)	Depth (m) - with Slab	
			BP1	BP2
25	Soft to Firm Clay	0.3	0.7	-
		0.45	0.7	0.9
		0.6	0.45	0.8
50	Stiff to Very Stiff Clay	0.3	0.7	-
		0.45	0.7	0.8
		0.6	0.45	0.8

Revision	Date	Initial	Purchaser Name: Jeannie Lewis		Specification Sheet Page 2 of 2 ©Copyright Steelx IP Pty Ltd	Seller: Steel Buildings Head Office Name: Wide Span Sheds Pty Ltd Phone: 07 5657 8888 Fax: 1800 427 400 Email: engineering@steelx.com.au	Apex Engineering Group PTY LTD ACN 632 588 562 MIE Aust. (Registered NER Structural) 5276680 QLD : RPEQ No. 24223; TAS : 185770492; VIC : PE0003848; N.T : 303557ES; Practising Professional Structural & Civil Engineers Signature:  John Ronaldson Date: 29/11/23
			Site Address: 22 Macquarie Street Neville NSW 2799 Australia				
			Drawing # ASBA234031 - 4	Print Date: 29/11/2023			

Cross Bracing is achieved with 1.2mm Strap. Refer to Connection Details.
 Cross bracing in the roof is to the purlin nearest to the end wall mullions, where applicable.

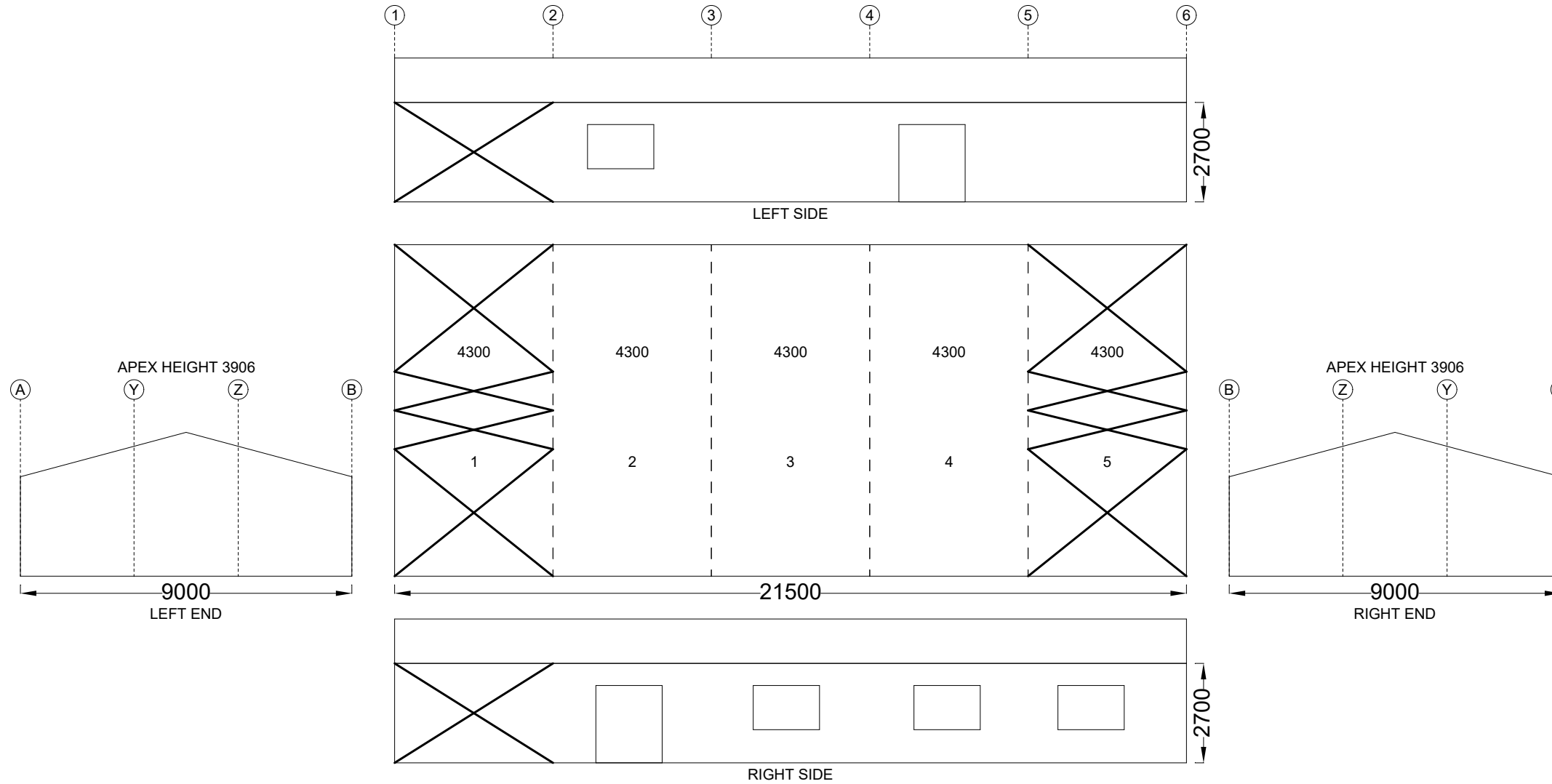

Revision	Date	Initial		
			Purchaser Name: Jeannie Lewis	
			Site Address: 22 Macquarie Street Neville NSW 2799 Australia	
			Drawing # ASBA234031 - 5	Print Date: 29/11/2023

Bracing

NOT TO SCALE

Page 1 of 1
 ©Copyright Steelx IP Pty Ltd

Seller: Steel Buildings Head Office
 Name: Wide Span Sheds Pty Ltd
 Phone: 07 5657 8888
 Fax: 1800 427 400
 Email: engineering@steelx.com.au

Apex Engineering Group PTY LTD
 ACN 632 588 562
 MIE Aust. (Registered NER Structural) 5276680
 QLD : RPEQ No. 24223; TAS : 185770492; VIC : PE0003848; N.T : 303557ES;
 Practising Professional Structural & Civil Engineers

Signature:  John Ronaldson
 Date: 29/11/23

These dimensions are provided as a guide only. It is the responsibility of the concreter to confirm that all dimensions are correct.
 Refer to Material Specifications Plan for BP dimensions.

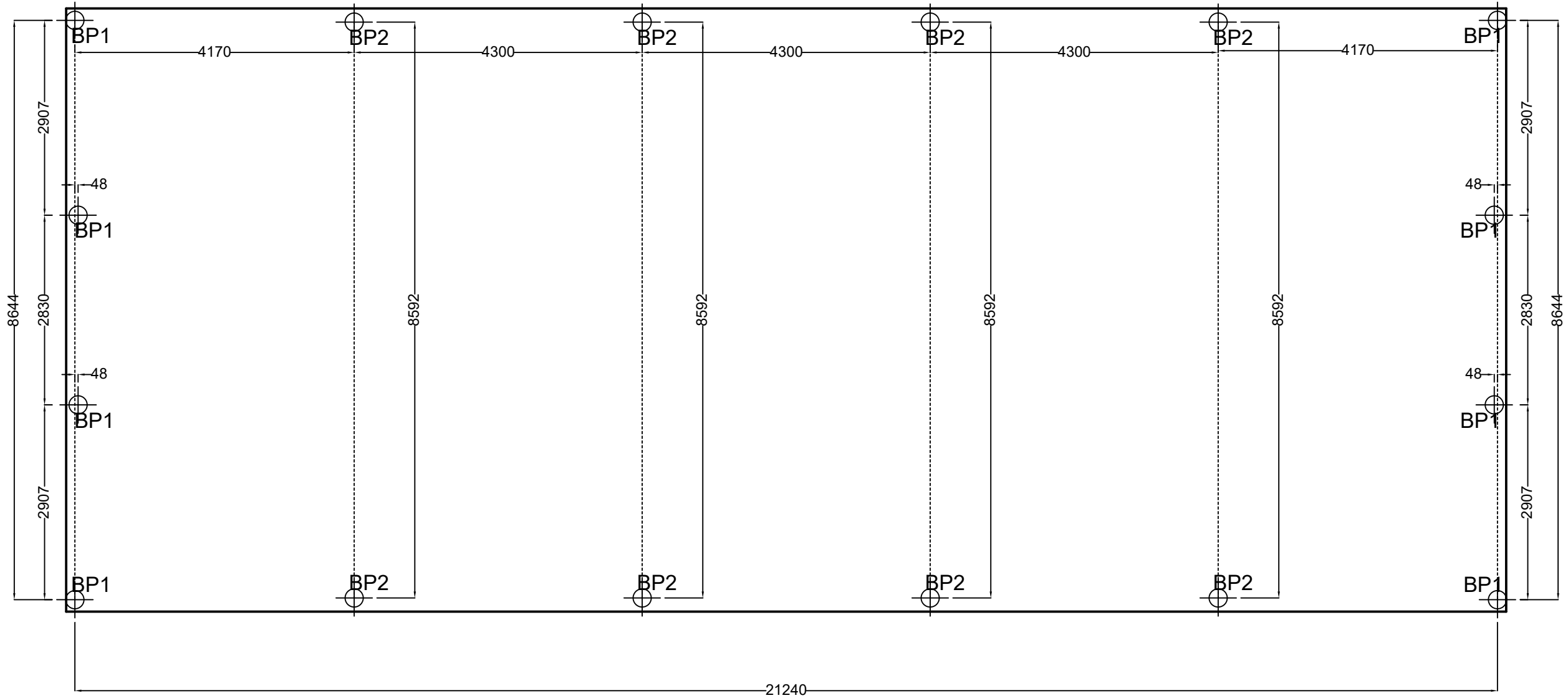

Revision	Date	Initial		
			Purchaser Name: Jeannie Lewis	
			Site Address: 22 Macquarie Street Neville NSW 2799 Australia	
			Drawing # ASBA234031 - 6	Print Date: 29/11/2023

Concrete Piers
 PIER MEASUREMENT ONLY
 NOT TO SCALE
 Page 1 of 1
 ©Copyright Steelx IP Pty Ltd

Seller: Steel Buildings Head Office
 Name: Wide Span Sheds Pty Ltd
 Phone: 07 5657 8888
 Fax: 1800 427 400
 Email: engineering@steelx.com.au

Apex Engineering Group PTY LTD
 ACN 632 588 562
 MIE Aust. (Registered NER Structural) 5276680
 QLD : RPEQ No. 24223; TAS : 185770492; VIC : PE0003848; N.T : 303557ES;
 Practising Professional Structural & Civil Engineers

Signature:  John Ronaldson
 Date: 29/11/23

These dimensions are provided as a guide only. It is the responsibility of the concreter to confirm that all dimensions are correct.

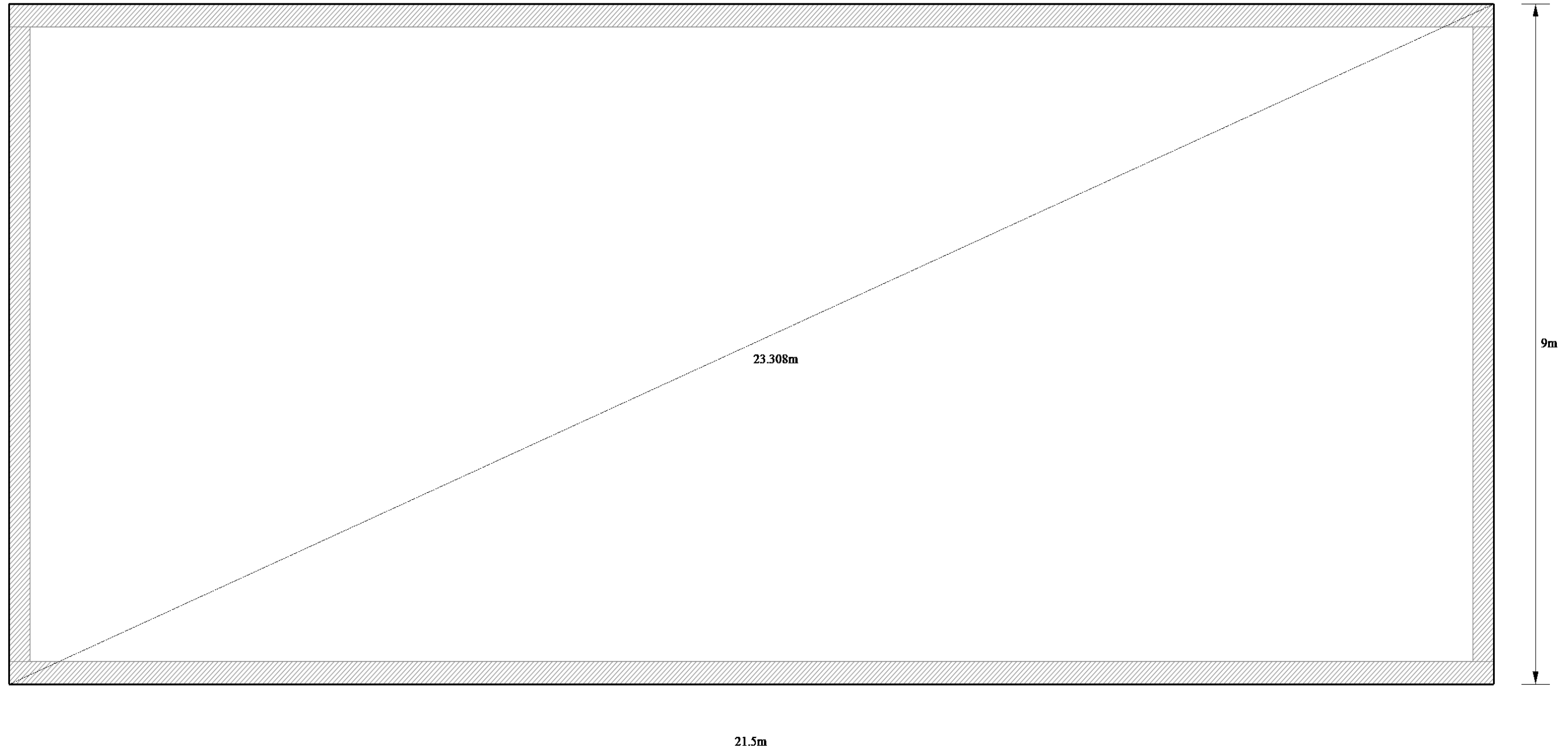

Purchaser Name: Jeannie Lewis

Site Address: 22 Macquarie Street Neville NSW 2799 Australia

Drawing # ASBA234031 - 7

Print Date: 29/11/23

Slab Dimensions
Class A or S
Also refer to Concrete Piers Plan
Not to Scale
Page 1 of 4
© Copyright Steelx IP Pty Ltd

Seller: Steel Buildings Head Office
Wide Span Sheds Pty Ltd
Phone: 07 5657 8888
Fax: 1800 427 400
Email: engineering@steelx.com.au

Apex Engineering Group PTY.LTD
ACN 632 588 562
ME Aust. (Registered NER Structural) 5276680
QLD : RPEQ No. 24223; TAS : 185770492; VIC : PE0003848; N.T : 303557ES;
Practising Professional Structural & Civil Engineers

Signature:

John Ronaldson

Date: 29/11/23

These dimensions are provided as a guide only. It is the responsibility of the concreter to confirm that all dimensions are correct.
Indicative Beam Layout. Refer to General Notes - Slab Details for maximum beam spacing.

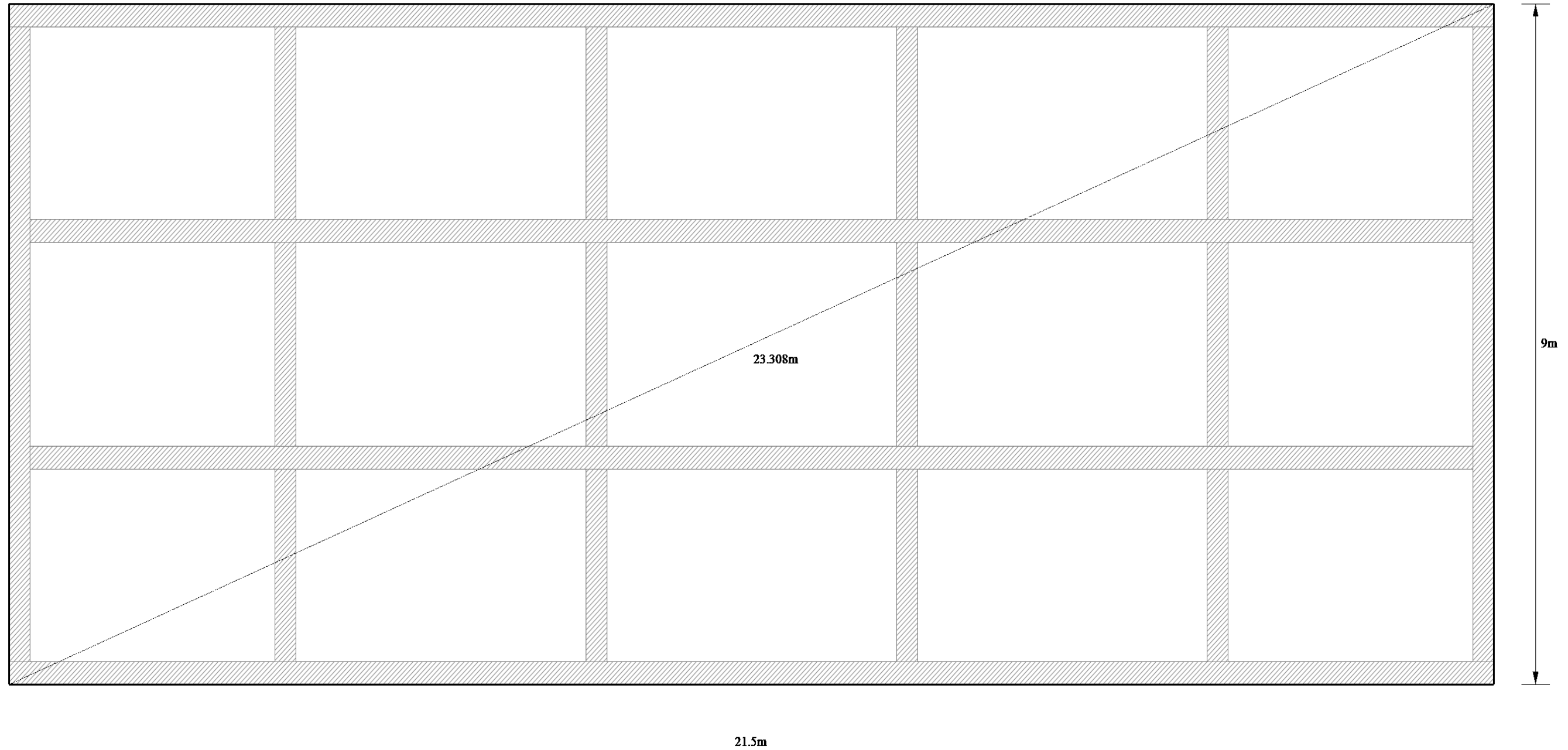

Purchaser Name: Jeannie Lewis

Site Address: 22 Macquarie Street Neville NSW 2799 Australia

Drawing # ASBA234031 - 7

Print Date: 29/11/23

Slab Dimensions
Class M
Also refer to Concrete Piers Plan
Not to Scale
Page 2 of 4
© Copyright Steelx IP Pty Ltd

Seller: Steel Buildings Head Office
Wide Span Sheds Pty Ltd
Phone: 07 5657 8888
Fax: 1800 427 400
Email: engineering@steelx.com.au

Apex Engineering Group PTY.LTD
ACN 632 588 562
ME Aust. (Registered NER Structural) 5276680
QLD : RPEQ No. 24223; TAS : 185770492; VIC : PE0003848; N.T : 303557ES;
Practising Professional Structural & Civil Engineers

Signature: 

John Ronaldson

Date: 29/11/23

These dimensions are provided as a guide only. It is the responsibility of the concreter to confirm that all dimensions are correct.
Indicative Beam Layout. Refer to General Notes - Slab Details for maximum beam spacing.

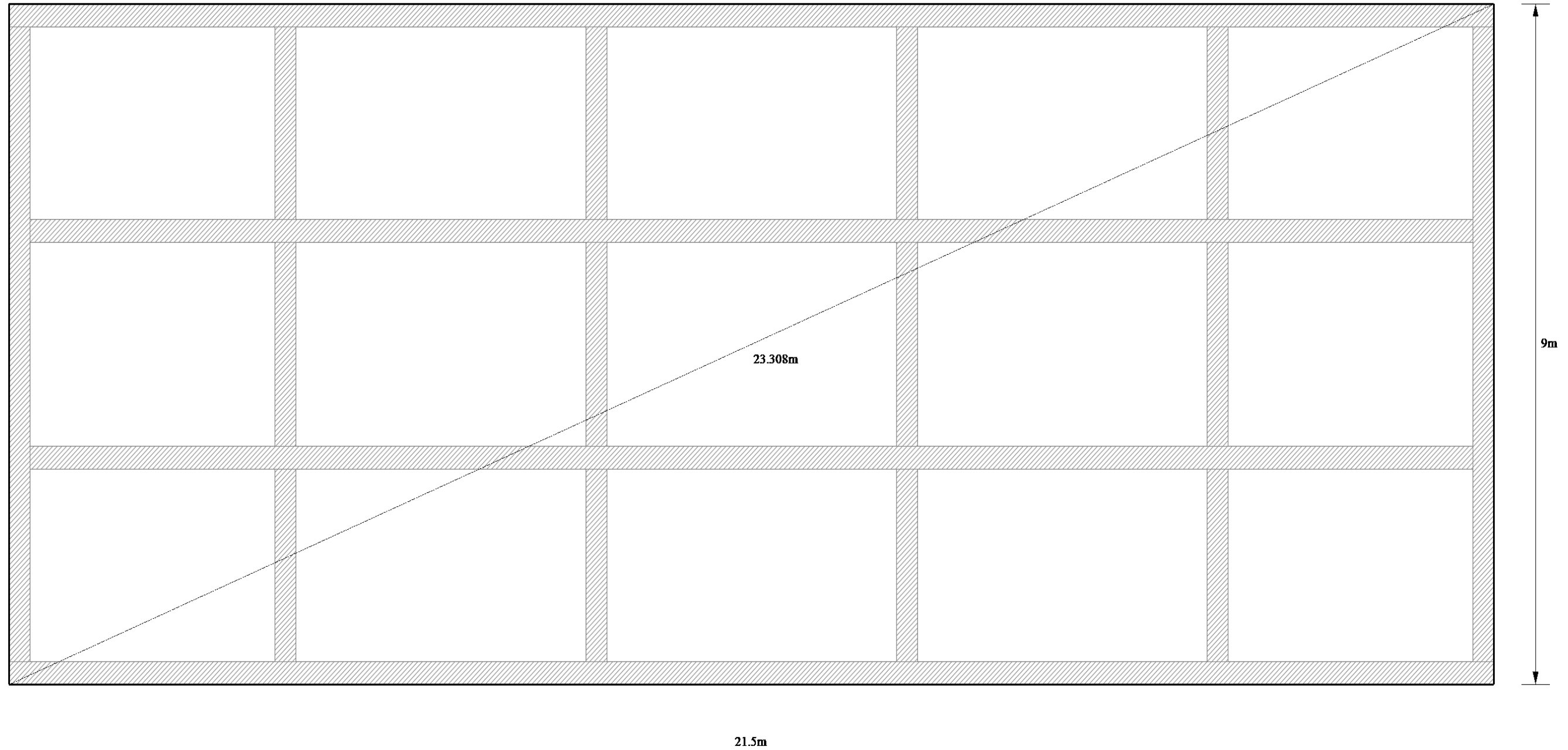

Purchaser Name: Jeannie Lewis

Site Address: 22 Macquarie Street Neville NSW 2799 Australia

Drawing # ASBA234031 - 7

Print Date: 29/11/23

Slab Dimensions
Class M-D or H1
Also refer to Concrete Piers Plan
Not to Scale
Page 3 of 4
© Copyright Steelx IP Pty Ltd

Seller: Steel Buildings Head Office
Wide Span Sheds Pty Ltd
Phone: 07 5657 8888
Fax: 1800 427 400
Email: engineering@steelx.com.au

Apex Engineering Group PTY.LTD
ACN 632 588 562
ME Aust. (Registered NER Structural) 5276680
QLD : RPEQ No. 24223; TAS : 185770492; VIC : PE0003848; N.T : 303557ES;
Practising Professional Structural & Civil Engineers

Signature: 

John Ronaldson

Date: 29/11/23

These dimensions are provided as a guide only. It is the responsibility of the concreter to confirm that all dimensions are correct.
 Indicative Beam Layout. Refer to General Notes - Slab Details for maximum beam spacing.

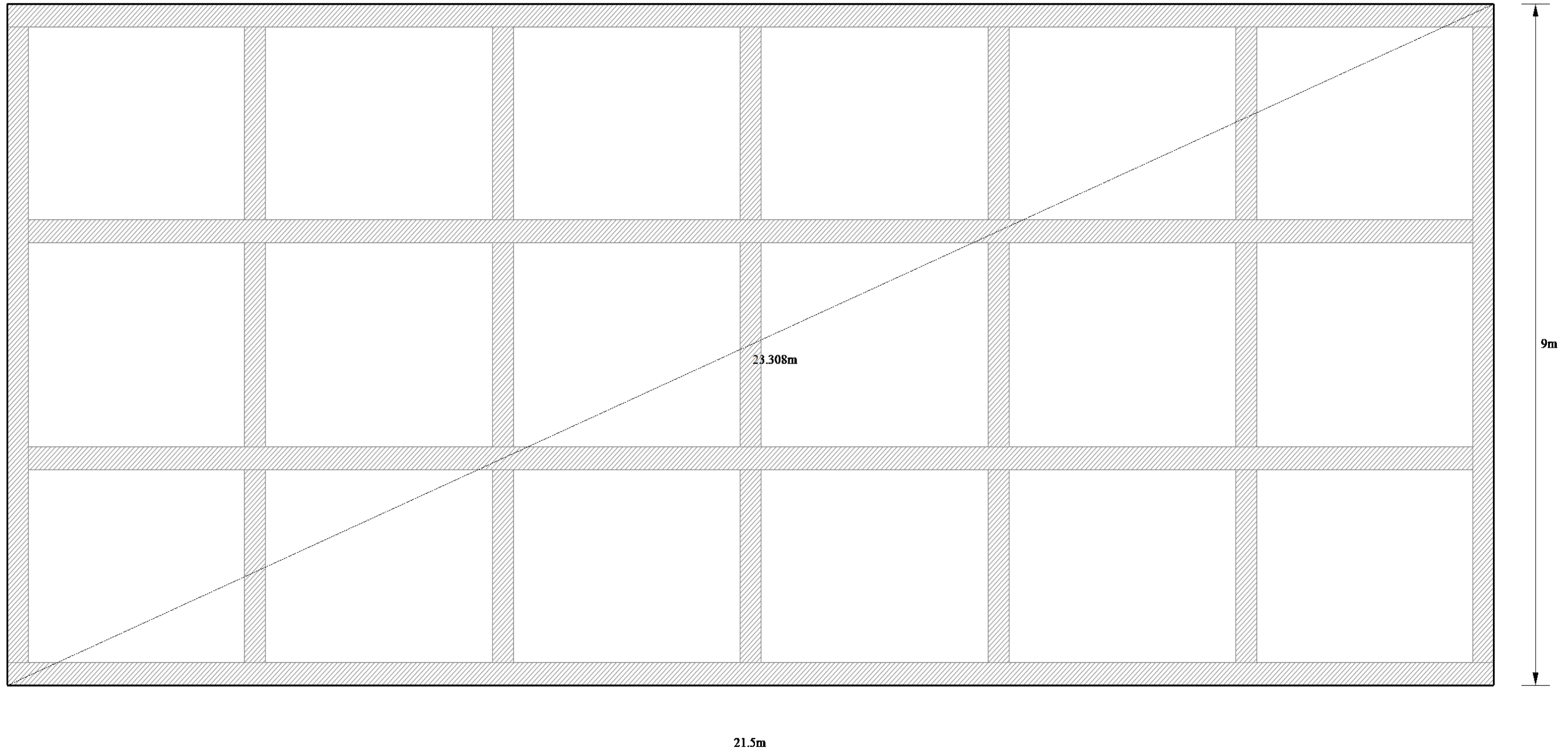

Purchaser Name: Jeannie Lewis	
Site Address: 22 Macquarie Street Neville NSW 2799 Australia	
Drawing # ASBA234031 - 7	Print Date: 29/11/23

Slab Dimensions
Class H1-D, H2 or H2-D
 Also refer to Concrete Piers Plan
 Not to Scale
 Page 4 of 4
 © Copyright Steelx IP Pty Ltd

Seller: Steel Buildings Head Office
 Wide Span Sheds Pty Ltd
 Phone: 07 5657 8888
 Fax: 1800 427 400
 Email: engineering@steelx.com.au

Apex Engineering Group PTY.LTD
 ACN 632 588 562
 ME Aust. (Registered NER Structural) 5276680
 QLD : RPEQ No. 24223; TAS : 185770492; VIC : PE0003848; N.T : 303557ES;
 Practising Professional Structural & Civil Engineers

Signature: 
 John Ronaldson
 Date: 29/11/23

SLAB NOTES

GENERAL NOTES ON STIFFENED RAFT SLAB

- G1. These drawings are only suitable for sites which have had a soil test carried out and where the ground movement is predominantly due to soil reactivity under normal moisture conditions. The designs attached only cater for sites classified as A, S, M, H1 and H2 as defined in AS2870. A minimum safe bearing capacity of 100kPa is required.
- G2. D, P and E sites are NOT covered. These sites should be designed by a local geotechnical engineer. Where a site requires cut and fill over 300mm across the pad area, then specific engineering drawings are required.
- G3. Fill placed after the Geotechnical report should be certified by a local geotechnical engineer as compacted to level 1 in accordance with AS3796.
- G4. Site drainage to protect the slab and footings from excessive moisture shall be provided. Refer to B2.2 and B2.3.
- G5. Slabs to be founded on a minimum of 50mm thick compacted granular base. Vapour barrier (Visqueen membrane – 0.2mm thick) to be placed under the entire slab. Bar chairs to be placed at a maximum of 900mm centres in both directions.
- G6. Concrete shall be a minimum of 25Mpa, a maximum of 80-100mm slump and a maximum of 20mm aggregate. Concrete must be pencil vibrated and cured for at least 7 days.
- G7. Provision for control of or allowance for shrinkage cracking shall be as follows:
Where brittle floor coverings (ceramic tiles and the like) are to be used over an area greater than 16m², extra measures shall be taken to control shrinkage and cracking. Such measures shall include one or more of the following:
-The amount of slab reinforcement shall not be less than SL92 or equivalent throughout the slab panels where brittle finishes are to be used. Alternatively, an additions sheet of slab mesh shall be placed in those areas.
-The bedding system for the brittle coverings shall be selected on the basis of the expected slab movement and the characteristics of the floor covering.
-The placement of floor coverings shall be delayed. NOTE: A minimum period of three months drying of the concrete is usually required. Refer to "Foundation Performance and Maintenance" below.

FOUNDATION PERFORMANCE AND MAINTENANCE

B1 GENERAL

The designs and design methods give in this Standard are based on the performance criteria in clause 1.3. Importantly, significant damage may be avoided provided that foundation site conditions are properly maintained. This is expressed in section 1 by the statement that the probability of failure for reasonable site conditions is low, but is higher if extreme conditions are encountered. It is neither possible nor economical to design for the extreme conditions that could occur in the foundations if a site is not properly maintained. The expected standard of foundation maintenance is described in Paragraph B2.

Some minor cracking and movement will occur in a significant proportion of buildings, particularly those on reactive clays, and the various levels of damage are discussed in Paragraph B3.

The performance requirements of a concrete floor in respect to shrinkage cracking and moisture reaction with adhesives are discussed in Paragraph B4.

A more extensive discussion of the material in Paragraphs B2 to B4 is contained in the CSIRO pamphlet, 10-91, "Guide to Home Owners on Foundation Maintenance and Footing Performance" and it's recommendations should be followed.

B2 FOUNDATION MAINTENANCE

B2.1 Foundation soils

All soils are effected by water. Silts are weakened by water and some sands can settle if heavily watered, but most problems arise on clay foundations. Clays swell and shrink due to changes in the moisture content and the potential amount of movement is implied in the site classification in this Standard, which is designed as follows:

- (a) A means stable (non-reactive).
- (b) S means slightly reactive.
- (c) M Means moderately reactive.
- (d) H1 and H2 means highly reactive.
- (e) E means extremely reactive.

Sites classified Class A and S may be treated as non-reactive sites in accordance with Paragraph B2.2. Sites classified as M, H1, H2 and E should comply with the recommendations given in Paragraph B2.3.

B2.2 Class A and S sites

Sands, silts and clays should be protected from becoming extremely wet by adequate attention to site drainage and prompt repair of plumbing leaks.

B2.3 Class M, H1, H2 and E sites

Sites classified as M, H1, H2 or E should be maintained at essentially stable moisture conditions and extremes of wetting and drying to be prevented. This will require attention to the following:

- (a) Drainage of the site: The site should be graded or drained so that water cannot pond against or near the building. The ground immediately adjacent to the building should be graded to a uniform fall of 50mm minimum away from the building over the first metre. The subfloor space for the buildings with suspended floors should be graded or drained to prevent ponding where this may affect the performance of the footing system. The site drainage recommendations should be maintained for the economic life of the building.
- (b) Limitation on gardens: The development of the gardens should not interfere with the drainage systems. Garden beds adjacent to the building should be avoided. Care should be taken to avoid over watering of gardens close to the building footings.
- (c) Restrictions on trees and shrubs planting of trees should be avoided near the foundation of a building or neighbouring building on reactive sites as they can cause damage due to drying of the clay at substantial distances. To reduce, but not eliminate, the possibility of damage, tree planting should be restricted to a distance from the structure of:
 - (i) 1.5 x mature height for Class E sites.
 - (ii) 1 x mature height for Class H1 and H2 sites.
 - (iii) 3/4 x mature height for Class M sites.

Where rows or groups of trees are involved, the distance from the buildings should be increased. Removal of trees from the site can also cause simulate problems.

- (d) Repair of leaks: Leaks in plumbing, including stormwater and sewerage drainage should be repaired promptly.

The level to which these measures are implemented depends on the reactivity of the site. The measures apply mostly to masonry buildings and masonry veneer buildings. For the frame buildings clad with timber or sheeting, lesser precautions may be appropriate.

B3 PERFORMANCE OF WALLS

It is acknowledged that minor foundation movements occur on nearly all sites and that it is impracticable to design a footing system that will protect the building from movement under all circumstances. The expected performance of footing systems design in accordance with the Standard is defined in terms of the damage classifications in Table C1. Appendix C.

Crack width is used as the major criterion for damage assessment, although tilting and twisting distortions can also influence the assessment. Local deviations of slope of walls exceeding 1/150 are undesirable. The assessment of damage may also be effected by where it occurs and the function of the building, although these effects are not likely to be significant in conventional buildings. In the classification of damage, account should also be taken of the history of the cracking. For most situations Category 0 or 1 should be the limit. However under adverse conditions, Category 2 should be expected although such damage should be rare. Significant damage is defined as Category 3 or worse.

For Category 1 or 2 damage, remedial action should consist of stabilising the moisture conditions of the clay and paying attention to repairing or disguising the visual damage. This should be regarded as part of the normal maintenance of buildings on reactive clays.

Even significant masonry cracking with crack widths over 5mm often has no influence on the function of the wall and only presents an aesthetic problem. Generally, the remedial action for such damage should start with an investigation to establish the cause of the damage. In many cases the treatment should consist of stabilising moisture conditions by physical barriers or paths or replenishing moisture in dry foundations. This may be followed by repair of the masonry and wherever possible added articulation should be included while repairs are being effected. Structural repairs to the footing system such as deep underpinning should only be considered as the last resort.

Underpinning should generally be avoided where the problem is related to reactive clays, although it is recognised there may be occasional situations where underpinning or other structural augmentation work is appropriate. None of these structural augmentation work should be undertaken without proper engineering appraisal.

In some cases, walls may be designed to span sagging footings and cantilever beyond hogging footings. In such cases, satisfactory performance will involve the wall remaining free of cracks and articulation joint movements, and remaining within the limits for the particular joint system.

B4 PERFORMANCE CONCRETE FLOORS

Shrinkage cracking can be expected in concrete floors. Concrete floors can also be damaged by swelling of reactive clays or settlement of fill. The categories of movement causing the damage are given in Table C2, Appendix C. In the classification, account should be taken of whether the damage is stable or likely to increase, and an allowance should be made for any deviations in the level which resulted from, or occurred during construction.

The time of attachment of floor coverings and the selection of the adhesive for them should take in to account the moisture and the concrete floor and its possible effect on adhesion. Concrete floors can take a considerable time to dry (three to nine months). Floor coverings and their adhesives can be damaged by moisture in the concrete and by the shrinkage that occurs as the concrete dries. Drying could take three months or more. The time of fixing of floor coverings and the selection of the adhesive should take these factors into account.

Purchaser Name: Jeannie Lewis

Site Address: 22 Macquarie Street Neville NSW 2799 Australia

Drawing # ASBA234031 - 8

Print Date: 29/11/23

Slab Notes

Page 1 of 1
© Copyright Steelx IP Pty Ltd

Seller: Steel Buildings Head Office
Wide Span Sheds Pty Ltd
Phone: 07 5657 8888
Fax: 1800 427 400
Email: engineering@steelx.com.au

Apex Engineering Group PTY LTD
ACN 632 588 562
ME Aust. (Registered NER Structural) 5276680
QLD : RPEQ No. 24223; TAS : 185770492; VIC : PE0003848; N.T : 303557ES;
Practising Professional Structural & Civil Engineers

Signature: 

John Ronaldson

Date: 29/11/23

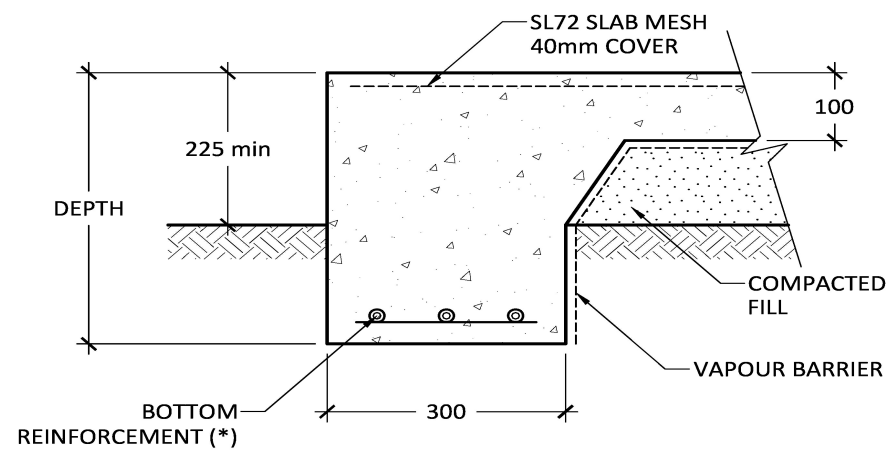

(*) REFER TO GENERAL NOTES FOR SPECIFICATION

EDGE BEAM

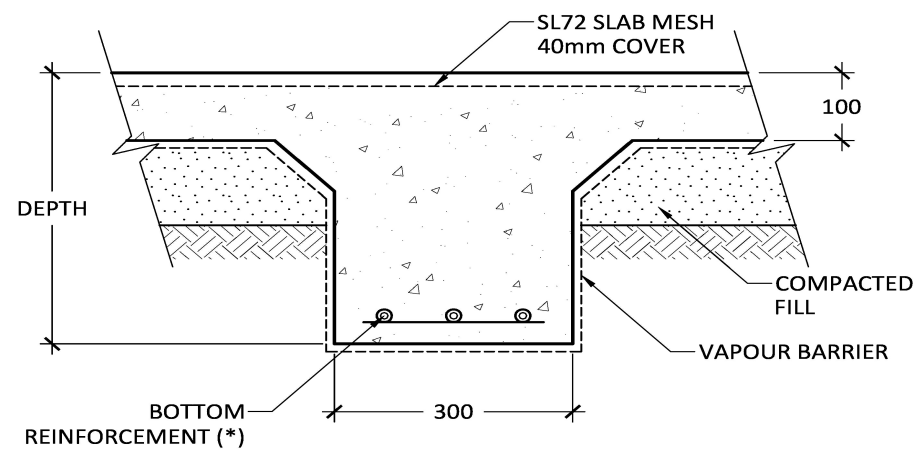

(*) REFER TO GENERAL NOTES FOR SPECIFICATION

INTERNAL BEAM

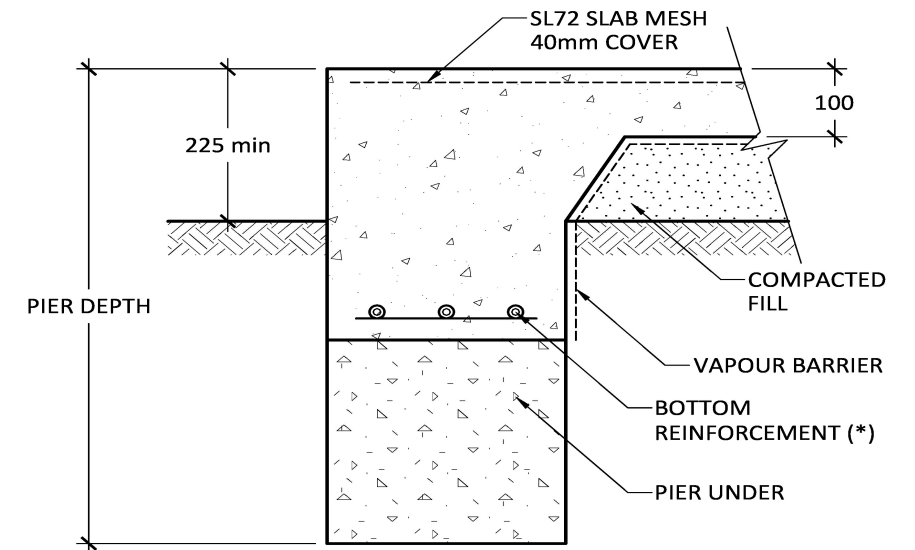

(*) REFER TO GENERAL NOTES FOR SPECIFICATION

PIER BEAM

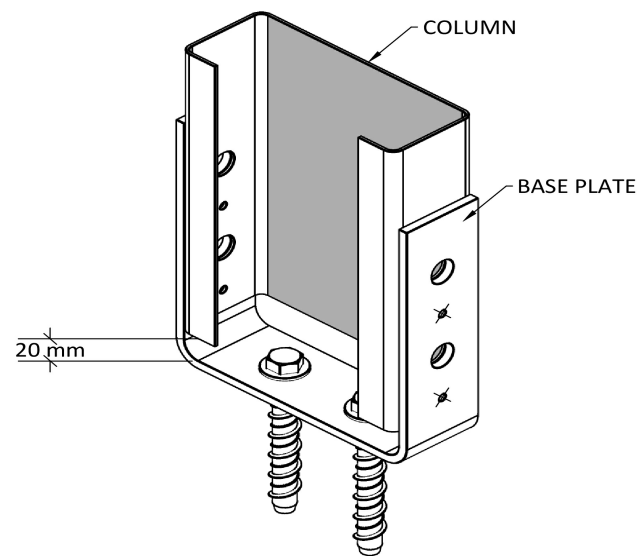

- FIXING BOLTS - 2 of M12 x 100 SCREWBOLT
- FIXING BOLTS - 4 of M12 x 30 Galv.
- × FIXING SCREWS - 4 of 12.24 x 38 Series 500

C150 COLUMN FIXING (BF)

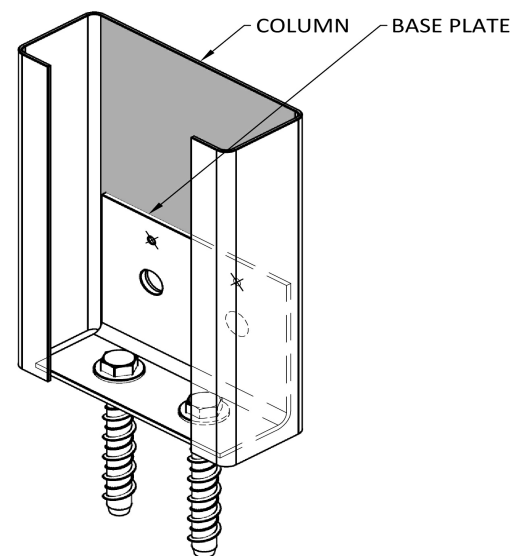

- FIXING BOLTS - 2 of M12 x 100 SCREWBOLTS
- FIXING BOLTS - 2 of M12 x 30 Galv.
- × FIXING SCREWS - 2 of 14.20 x 22

C150 MULLION BASE PLATE (B)

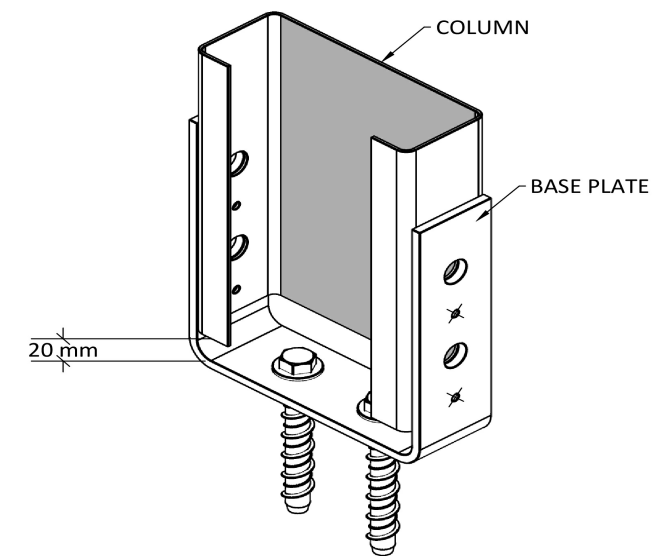

- FIXING BOLTS - 2 of M12 x 100 SCREWBOLT
- FIXING BOLTS - 4 of M12 x 30 Galv.
- × FIXING SCREWS - 4 of 12.24 x 38 Series 500

C200 COLUMN FIXING (BF)

Purchaser Name: Jeannie Lewis

Site Address: 22 Macquarie Street Neville NSW 2799 Australia

Drawing # ASBA234031 - 9

Print Date: 29/11/23

Connection Details

Not to Scale
Page 1 of 5
© Copyright Steelx IP Pty Ltd

Seller: Steel Buildings Head Office
Wide Span Sheds Pty Ltd
Phone: 07 5657 8888
Fax: 1800 427 400
Email: engineering@steelx.com.au

Apex Engineering Group PTY LTD
ACN 632 588 562
MIE Aust. (Registered NER Structural) 5276680
QLD : RPEQ No. 24223; TAS : 185770492; VIC : PE0003848; N.T : 303557ES;
Practising Professional Structural & Civil Engineers

Signature:

John Ronaldson

Date: 29/11/23

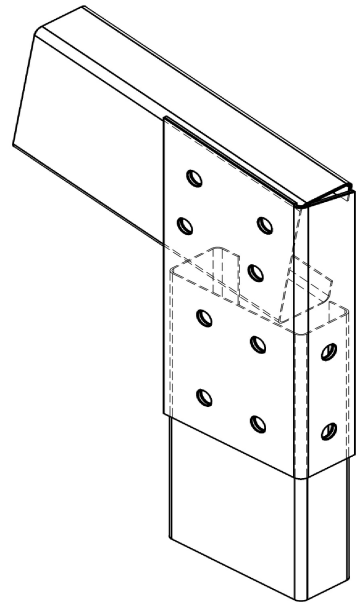

○ FIXING BOLTS - 10 of M12 x 30 (8.8)

FLAT PLATE HAUNCH BRACKET (X&Y) - C150, 15°

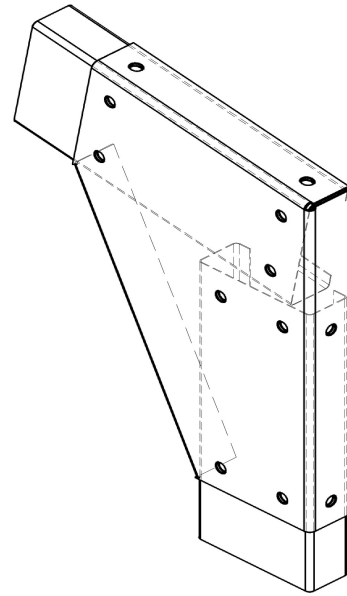

○ FIXING BOLTS - 12 of M12 x 30 (8.8)

KNEE HAUNCH BRACKET (HS&HT) - C200, 15°

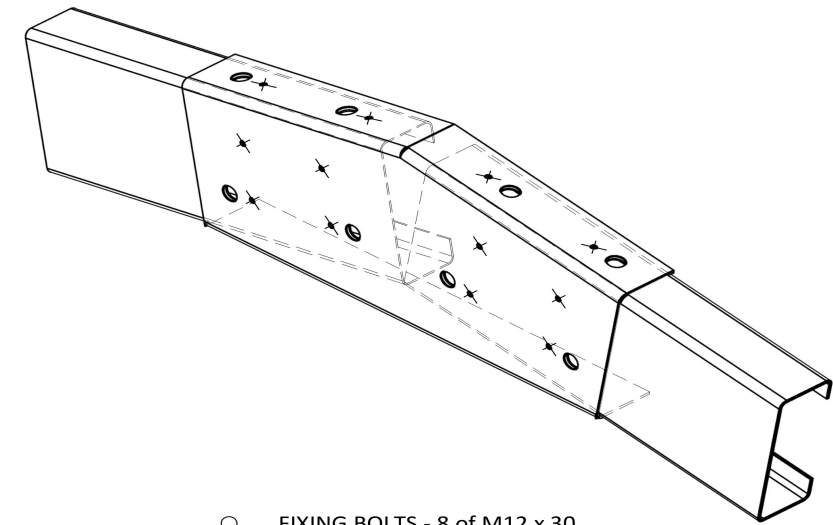

○ FIXING BOLTS - 8 of M12 x 30
 × FIXING SCREWS - 12 of 14.20 x 22

APEX PLATE, C150, 15°

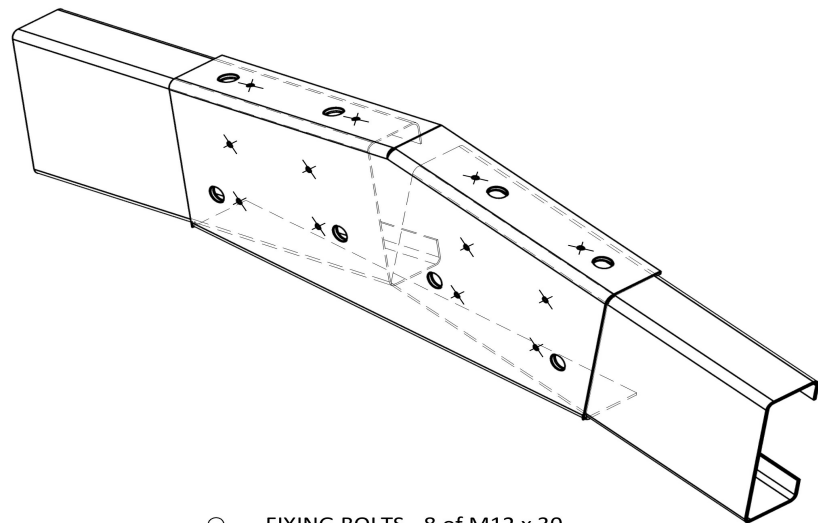

○ FIXING BOLTS - 8 of M12 x 30
 × FIXING SCREWS - 12 of 14.20 x 22

APEX PLATE, C200, 15°

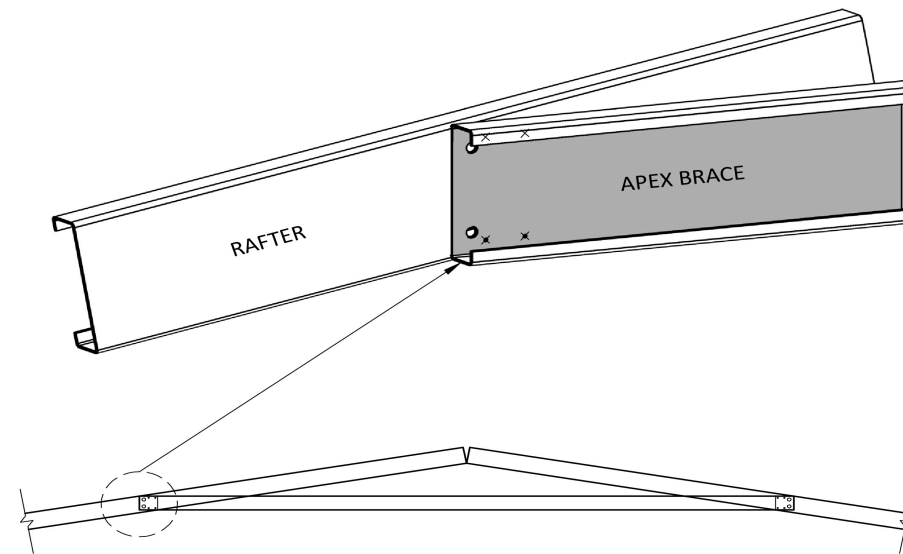

○ FIXING BOLTS - 2 of M12 x 30 (8.8)
 × FIXING SCREWS - 4 of 14.20 x 22

APEX BRACE FOR SINGLE RAFTER - C200-C150

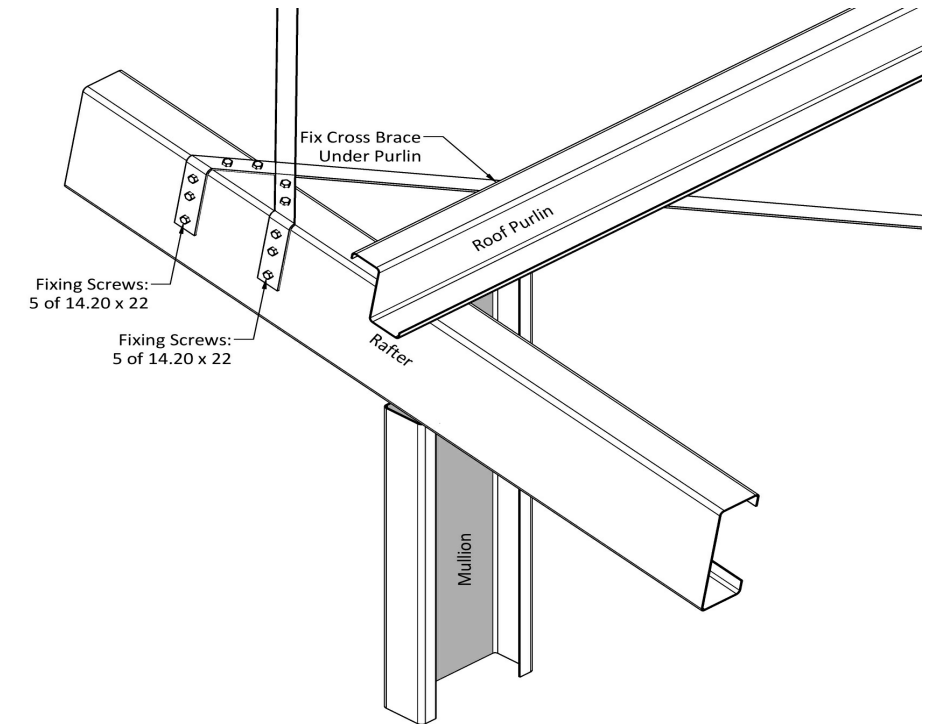

Fixing Screws:
 5 of 14.20 x 22

Fix Cross Brace
 Under Purlin

BRACING CONNECTION

Purchaser Name: Jeannie Lewis

Site Address: 22 Macquarie Street Neville NSW 2799 Australia

Drawing # ASBA234031 - 9

Print Date: 29/11/23

Connection Details

Not to Scale
 Page 2 of 5
 © Copyright Steelx IP Pty Ltd

Seller: Steel Buildings Head Office
 Wide Span Sheds Pty Ltd
 Phone: 07 5657 8888
 Fax: 1800 427 400
 Email: engineering@steelx.com.au

Apex Engineering Group PTY LTD
 ACN 632 588 562
 MIE Aust. (Registered NER Structural) 5276680
 QLD : RPEQ No. 24223; TAS : 185770492; VIC : PE0003848; N.T : 303557ES;
 Practising Professional Structural & Civil Engineers

Signature:

John Ronaldson

Date: 29/11/23

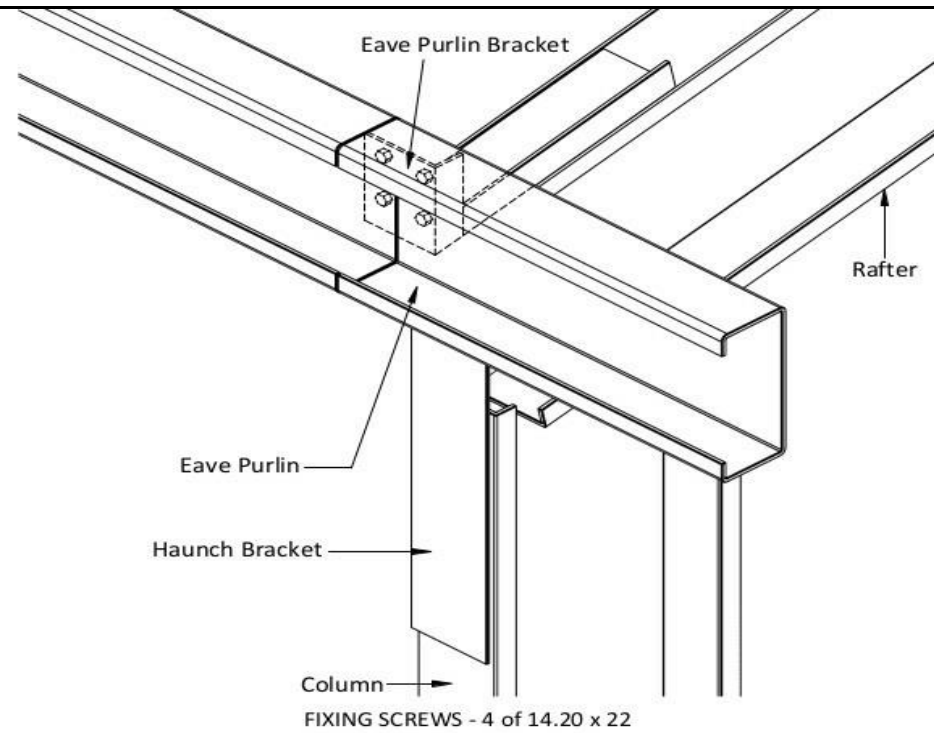

EAVE PURLIN TO EAVE PURLIN BRACKET

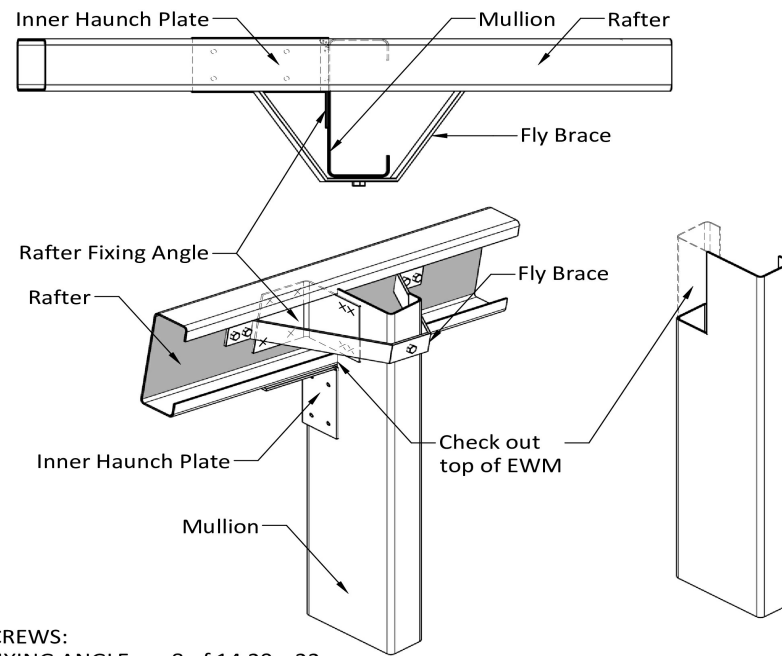

- FIXING SCREWS:**
 RAFTER FIXING ANGLE - 8 of 14.20 x 22
 INNER HAUNCH PLATE - 8 of 14.20 x 22
 FLY BRACE - 5 of 14.20 x 22

END WALL MULLION TO RAFTER

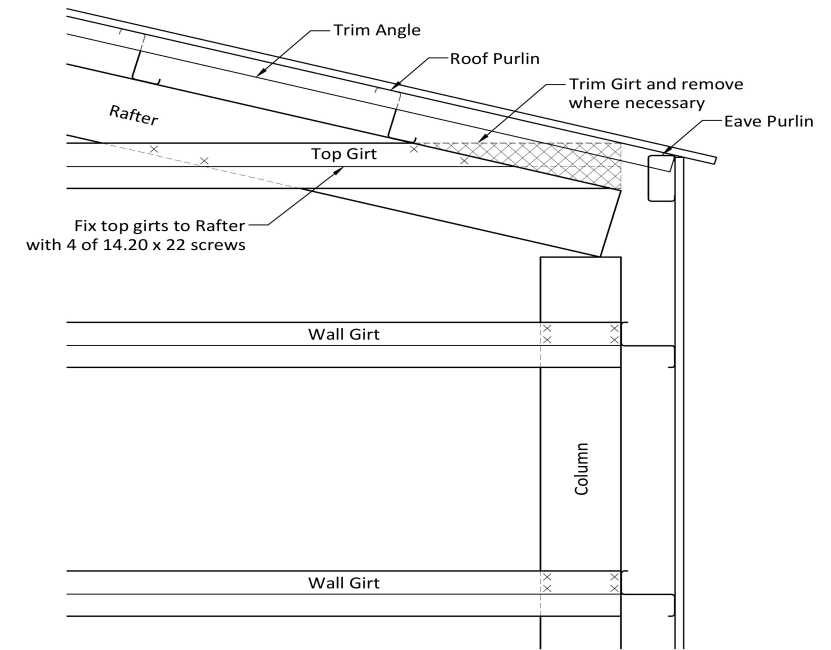

GABLE END TOP GIRT FIXING - Z

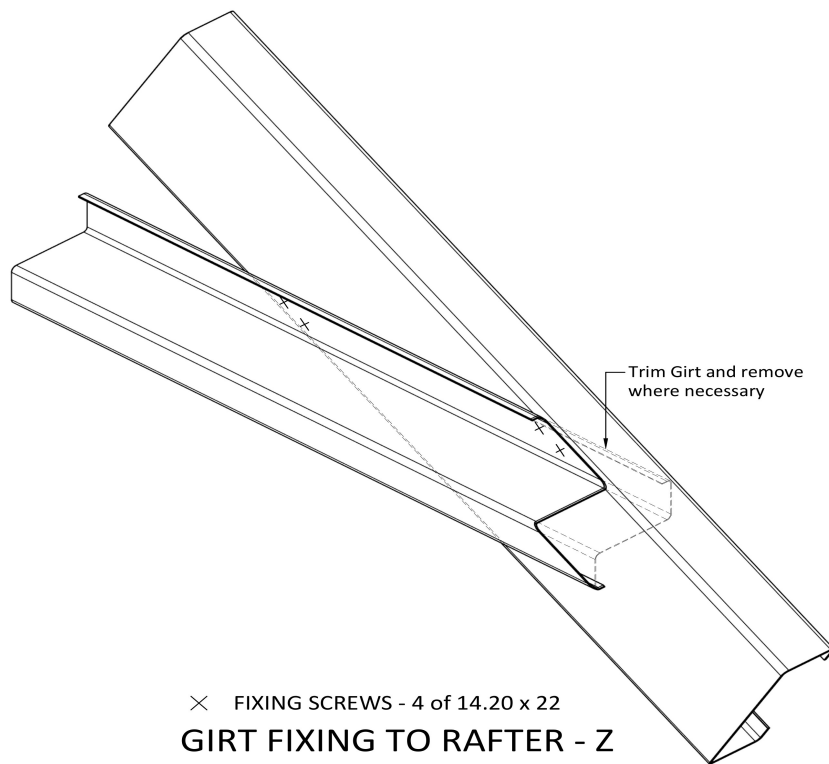

GIRT FIXING TO RAFTER - Z

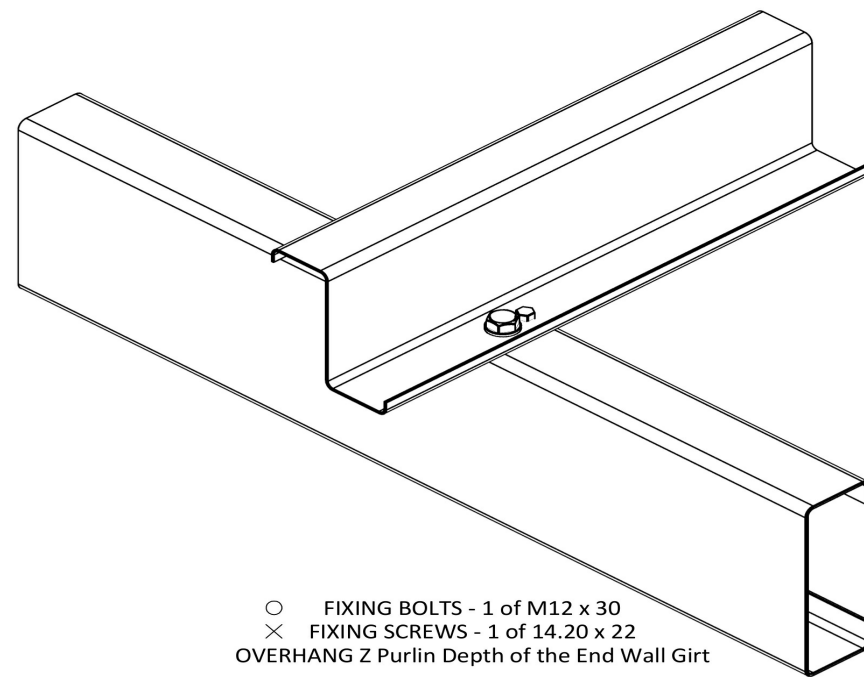

**PURLIN & SIDE GIRT END WALL FIXING
 Z PURLIN - SINGLE COLUMN OR RAFTER**

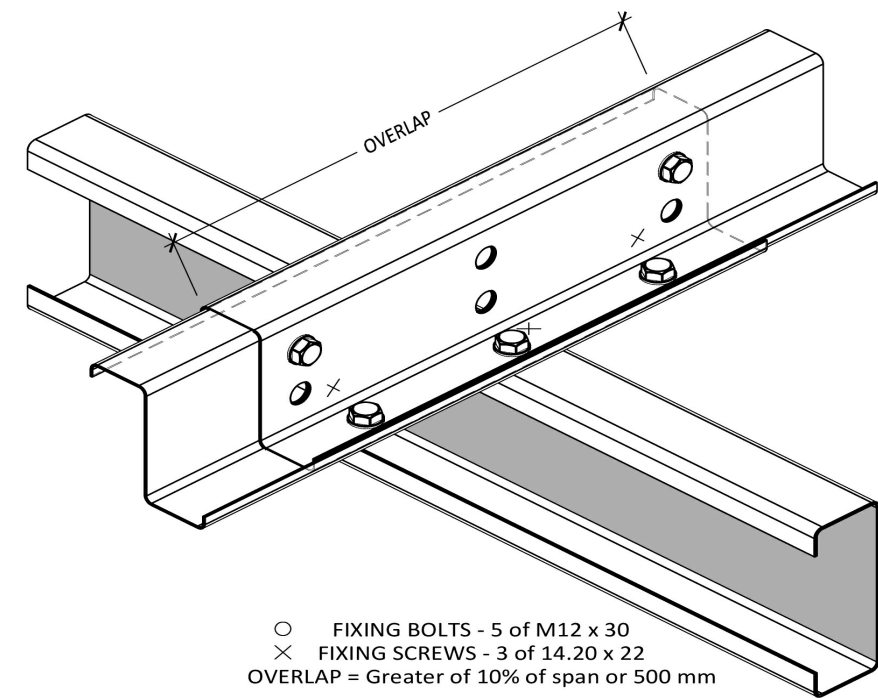

**PURLIN/GIRT FIXING
 SINGLE C SECTION COLUMNS OR RAFTERS**

Purchaser Name: Jeannie Lewis

Site Address: 22 Macquarie Street Neville NSW 2799 Australia

Drawing # ASBA234031 - 9

Print Date: 29/11/23

Connection Details

Not to Scale
 Page 3 of 5
 © Copyright Steelx IP Pty Ltd

Seller: Steel Buildings Head Office
 Wide Span Sheds Pty Ltd
 Phone: 07 5657 8888
 Fax: 1800 427 400
 Email: engineering@steelx.com.au

Apex Engineering Group PTY LTD
 ACN 632 588 562
 MIE Aust. (Registered NER Structural) 5276680
 QLD : RPEQ No. 24223; TAS : 185770492; VIC : PE0003848; N.T. : 303557ES;
 Practising Professional Structural & Civil Engineers

Signature:

John Ronaldson

Date: 29/11/23

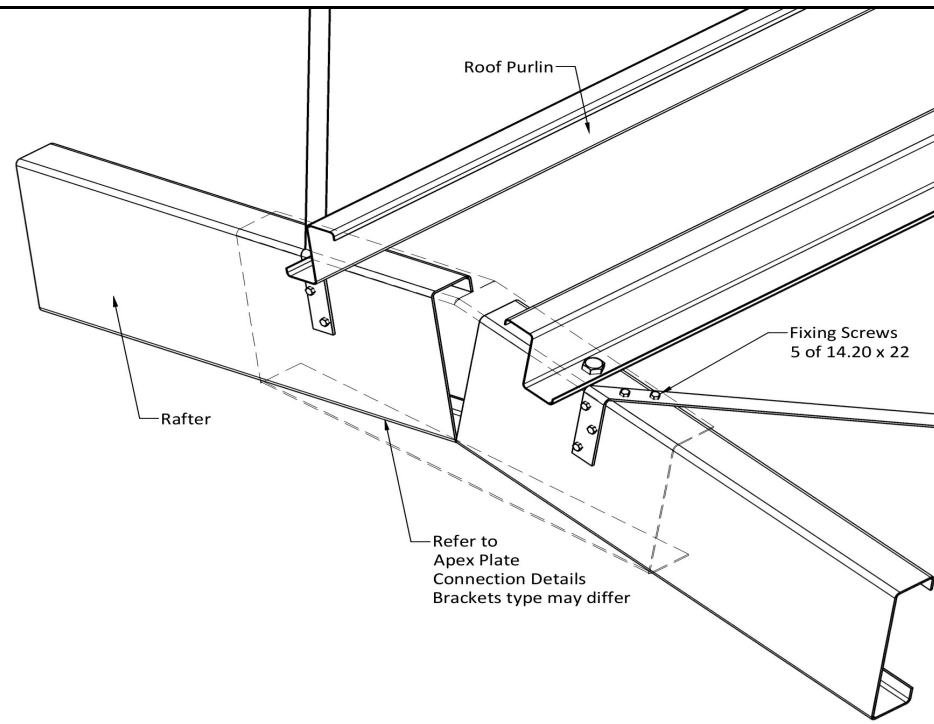

BRACING CONNECTION AT APEX

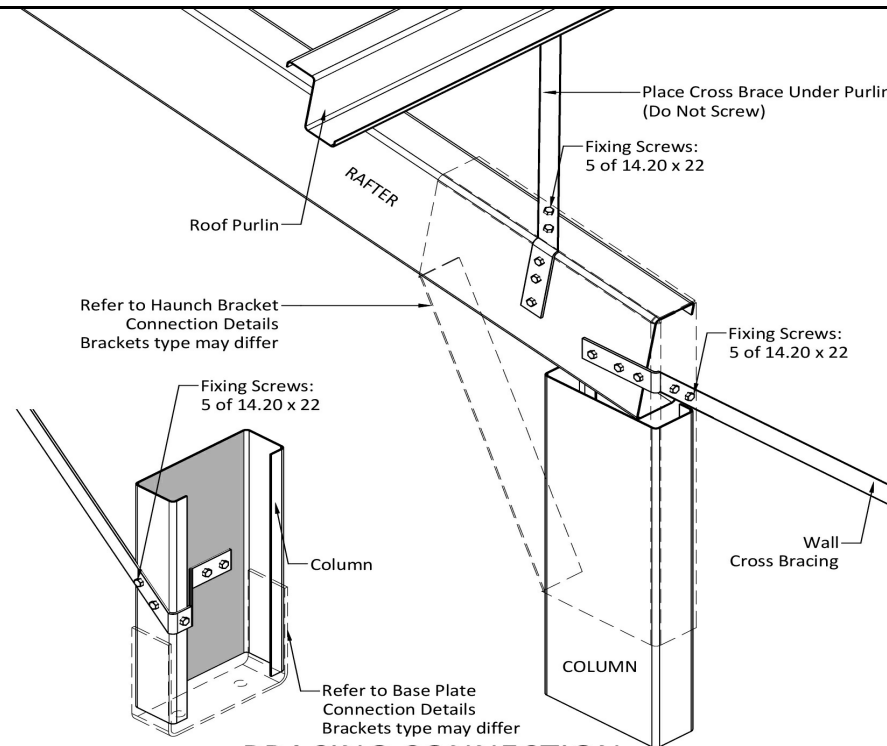

BRACING CONNECTION

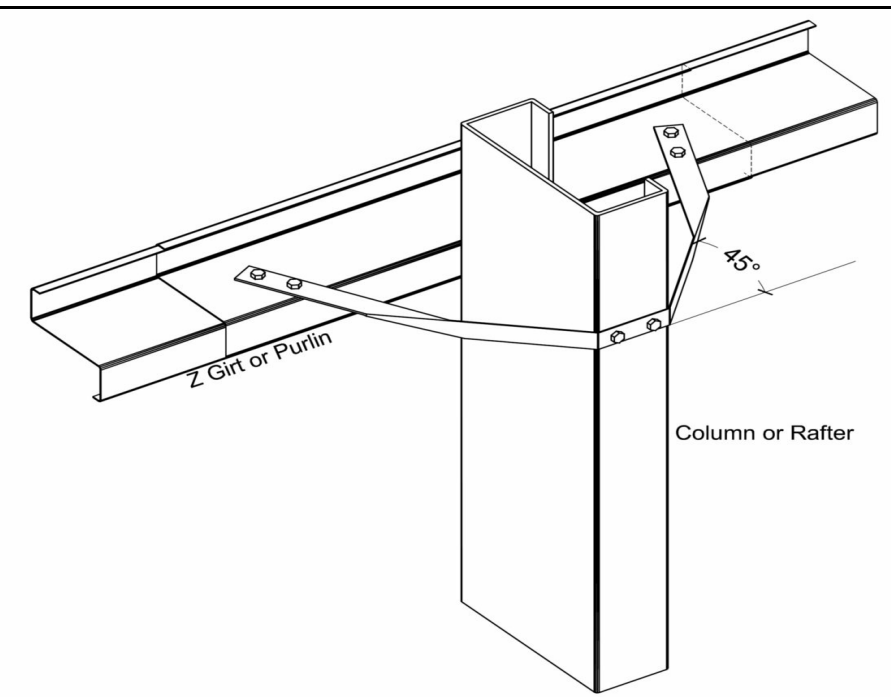

FLY BRACING

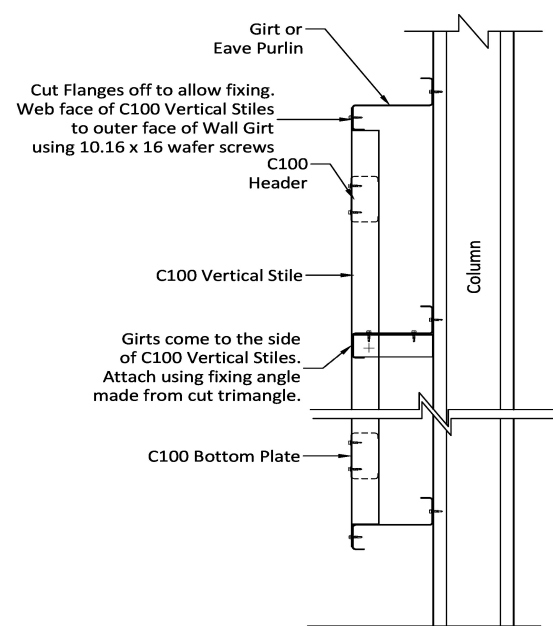

Window Frame (Over 900 High and 1500 Wide)
Note: Top of Window 2100 above GL

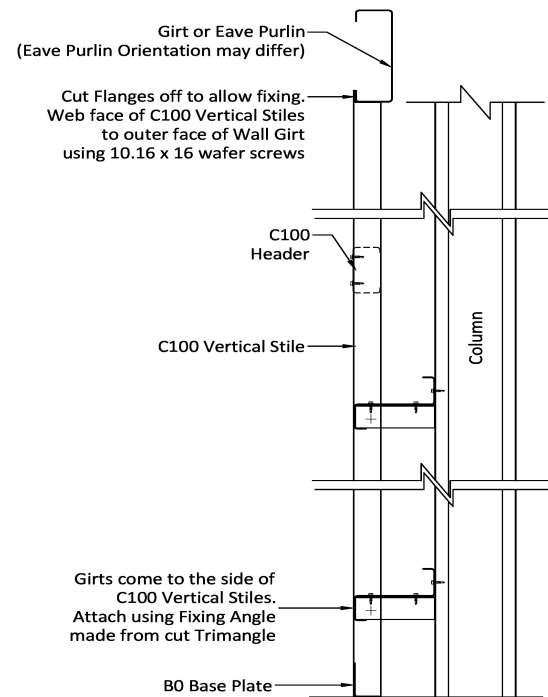

GSD - TO FLOOR LEVEL
Note: Top of Door 2100 above GL

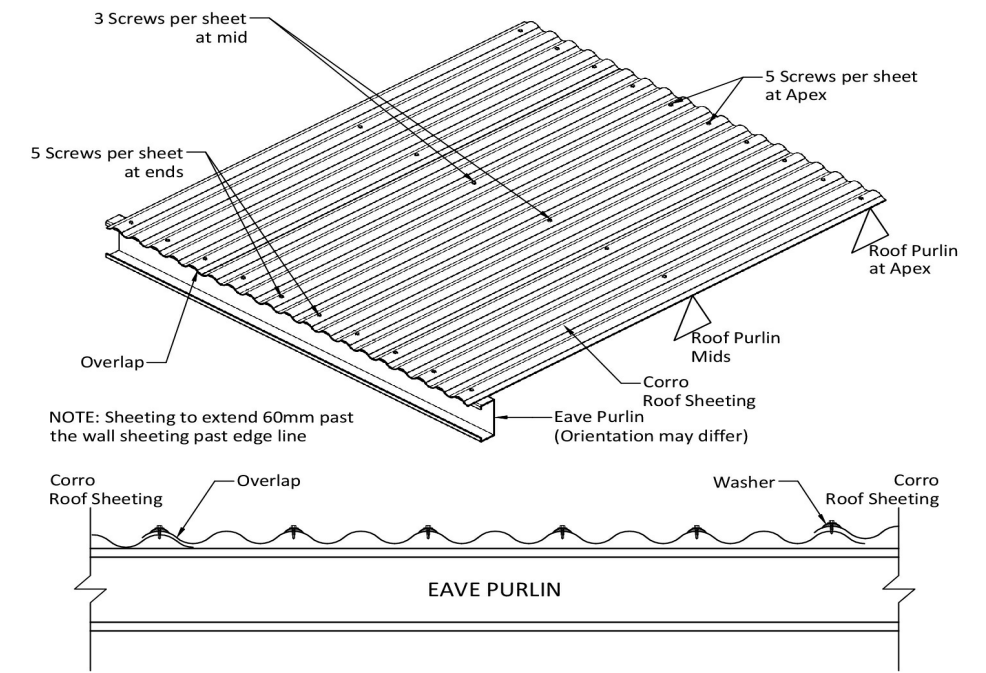

CORRO ROOF SHEET FIXING
Roofing Screws - 12.14 x 42 Hex Seal High Grip

Purchaser Name: Jeannie Lewis

Site Address: 22 Macquarie Street Neville NSW 2799 Australia

Drawing # ASBA234031 - 9

Print Date: 29/11/23

Connection Details
Not to Scale
Page 4 of 5
© Copyright Steelx IP Pty Ltd

Seller: Steel Buildings Head Office
Wide Span Sheds Pty Ltd
Phone: 07 5657 8888
Fax: 1800 427 400
Email: engineering@steelx.com.au

Apex Engineering Group PTY LTD
ACN 632 588 562
MIE Aust. (Registered NER Structural) 5276680
QLD : RPEQ No. 24223; TAS : 185770492; VIC : PE0003848; N.T : 303557ES;
Practising Professional Structural & Civil Engineers

Signature:

John Ronaldson

Date: 29/11/23

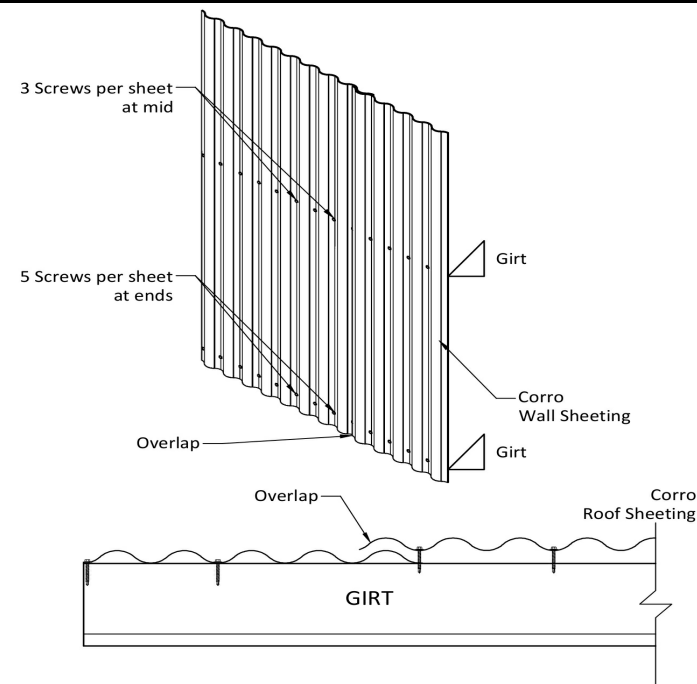

Wall Screws - 10.16 x 16 Hex

WALL SHEETING CONNECTION DETAILS

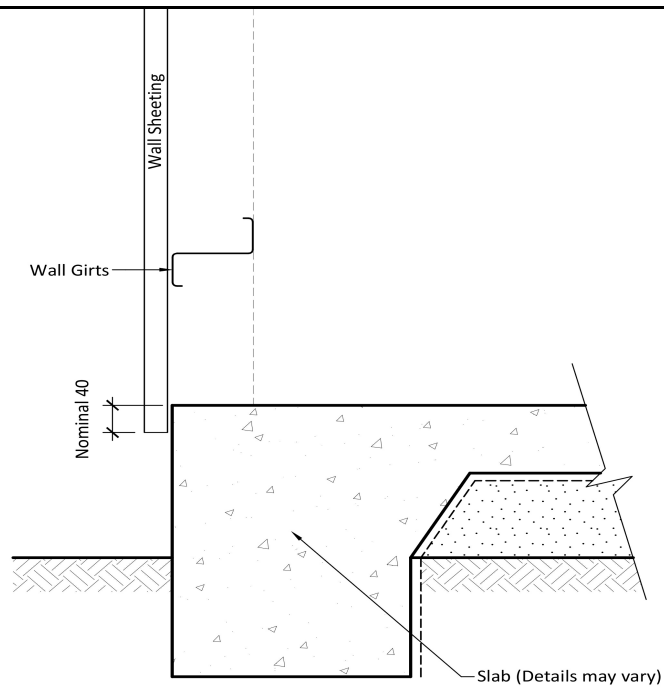

WALL SHEET OVERHANG DETAIL

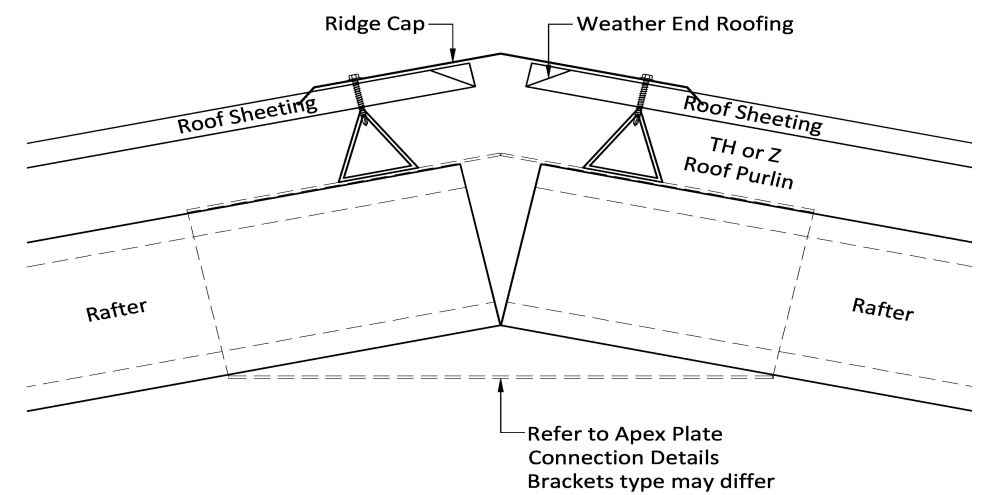

Ridge Cap - 2XF282

Purchaser Name: Jeannie Lewis

Site Address: 22 Macquarie Street Neville NSW 2799 Australia

Drawing # ASBA234031 - 9

Print Date: 29/11/23

Connection Details

Not to Scale
Page 5 of 5
© Copyright Steelx IP Pty Ltd

Seller: Steel Buildings Head Office
Wide Span Sheds Pty Ltd
Phone: 07 5657 8888
Fax: 1800 427 400
Email: engineering@steelx.com.au

Apex Engineering Group PTY LTD
ACN 632 588 562
MIE Aust. (Registered NER Structural) 5276680
QLD : RPEQ No. 24223; TAS : 185770492; VIC : PE0003848; N.T : 303557ES;
Practising Professional Structural & Civil Engineers

Signature:

John Ronaldson

Date: 29/11/23

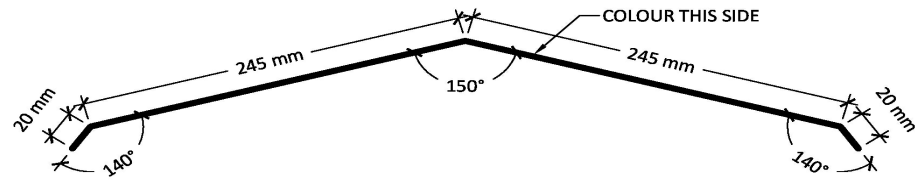

15° Ridge Capping - Z - Corodek
2XF282

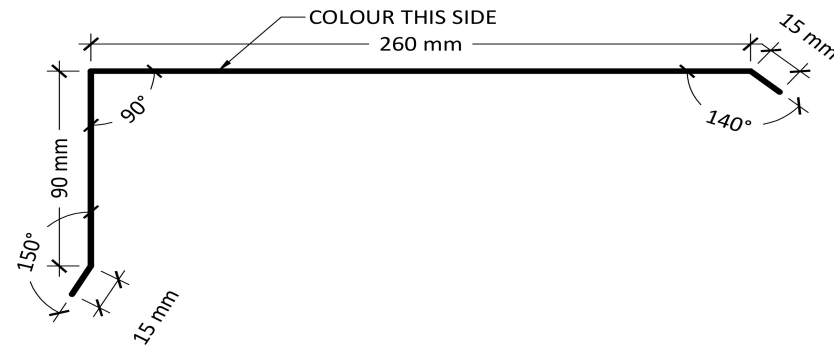

Barge Capping - Corodek
XF10

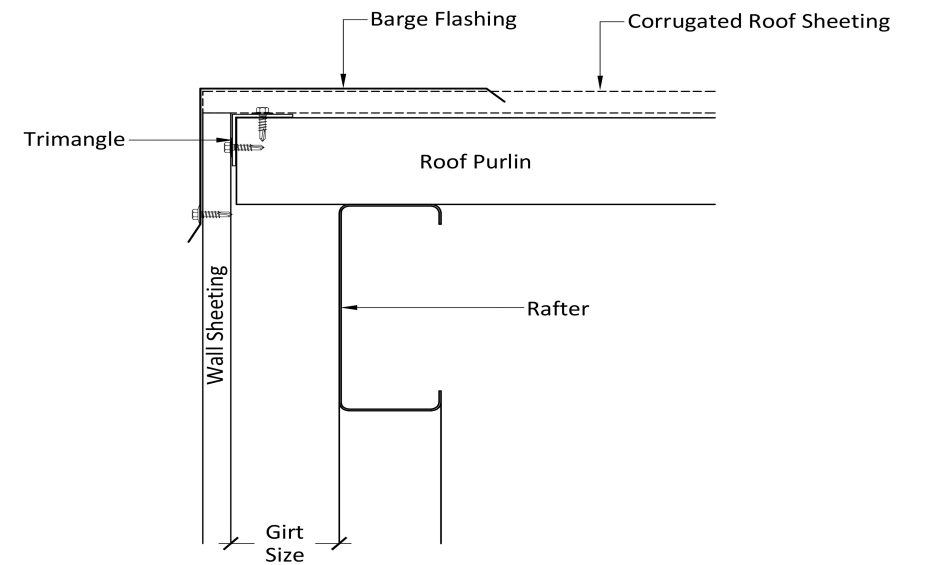

Barge Flashing XF10 - Sheeting Gable

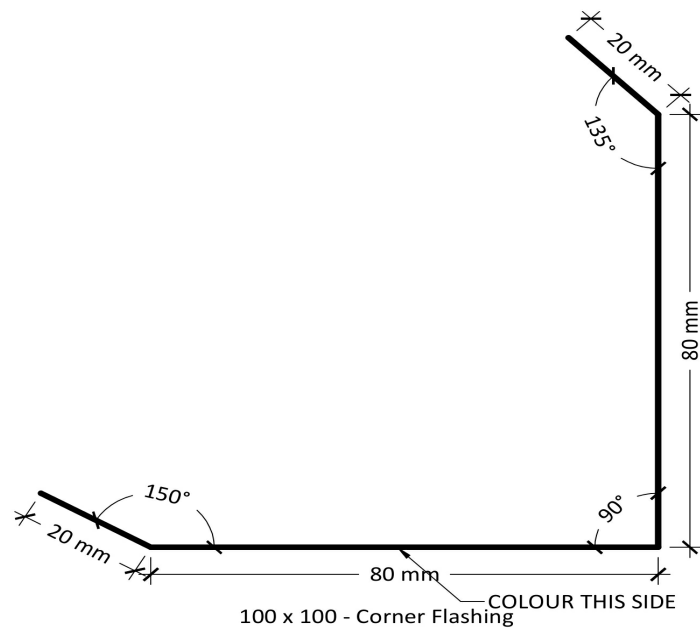

100 x 100 - Corner Flashing
XF21

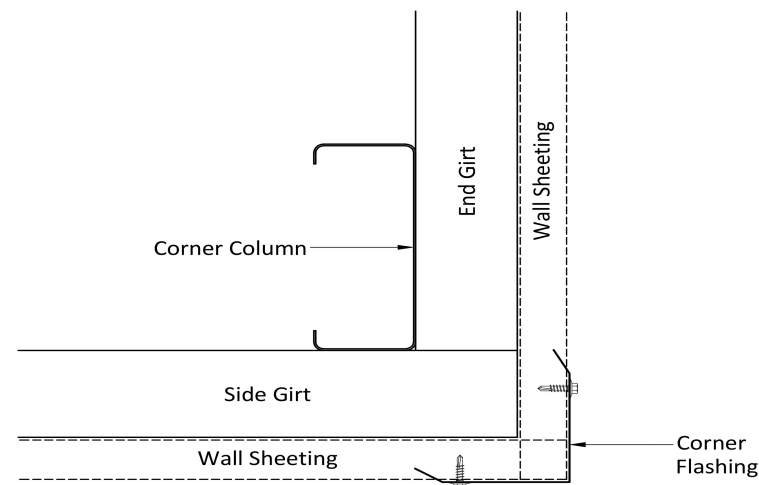

Corner Flashing XF21 - Connection

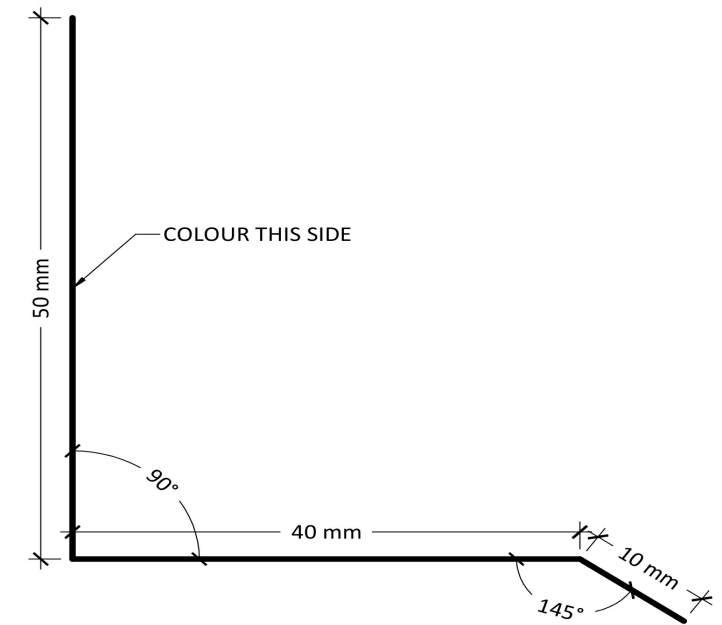

Window Header Flashing
XF26

Purchaser Name: Jeannie Lewis

Site Address: 22 Macquarie Street Neville NSW 2799 Australia

Drawing # ASBA234031 - 10

Print Date: 29/11/23

Flashing Fixing Details

Not to Scale
Page 1 of 2
© Copyright Steelx IP Pty Ltd

Seller: Steel Buildings Head Office
Wide Span Sheds Pty Ltd
Phone: 07 5657 8888
Fax: 1800 427 400
Email: engineering@steelx.com.au

Apex Engineering Group PTY LTD
ACN 632 588 562
ME Aust. (Registered NER Structural) 5276680
QLD : RPEQ No. 24223; TAS : 185770492; VIC : PE0003848; N.T. : 303557ES;
Practising Professional Structural & Civil Engineers

Signature:

John Ronaldson

Date: 29/11/23