

- CONCRETE NOTES**
- COVER (UON): 50mm
 - CONCRETE: S32
 - REQ: TYPE 'N' DEFORMED BAR (GRADE 500mPa)

DATUM 0.000 = RL ???

ISSUED FOR REVIEW NOT FOR CONSTRUCTION

FRASER LEVER
CONSULTING ENGINEERS
PH: +61 7 3162 3000
VIC: fraserlever.com.au
EMAIL: admin@fraserlever.com.au



DESIGNED				CENTRAL HIGHLANDS REGIONAL COUNCIL BLACKWATER RECYCLE WATER PIPELINE PURPLE TANK VALVE STATION GENERAL ARRANGEMENT & DETAILS - CIVILS	
DRAWN				SCALE	1:25
CHECKED				DRAWING NO.	PE1240-00-CC001-CC-DRG001
APPROVED				REV.	A

THIS DRAWING IS PROPERTY OF FRASERLEVER PVT. LTD. IT IS TO BE USED ONLY BY THE CLIENT AND IS NOT TO BE REPRODUCED OR USED IN ANY MANNER WITHOUT THE WRITTEN PERMISSION OF FRASERLEVER PVT. LTD. ANY THIRD PARTY OR USER DIRECTLY OR INDIRECTLY FOR ANY PURPOSES WITHOUT THE WRITTEN PERMISSION OF FRASERLEVER PVT. LTD. IS IN BREACH OF THE TERMS AND CONDITIONS OF THE FRASERLEVER PVT. LTD. SOFTWARE LICENSE AGREEMENT.

REFERENCE DWG. NO.	REFERENCE DESCRIPTION	REV	BY	DATE	ISSUE FOR INFORMATION	DFH	DFH
				15.06.2025			
					REVISION DESCRIPTION	CHK	ENG

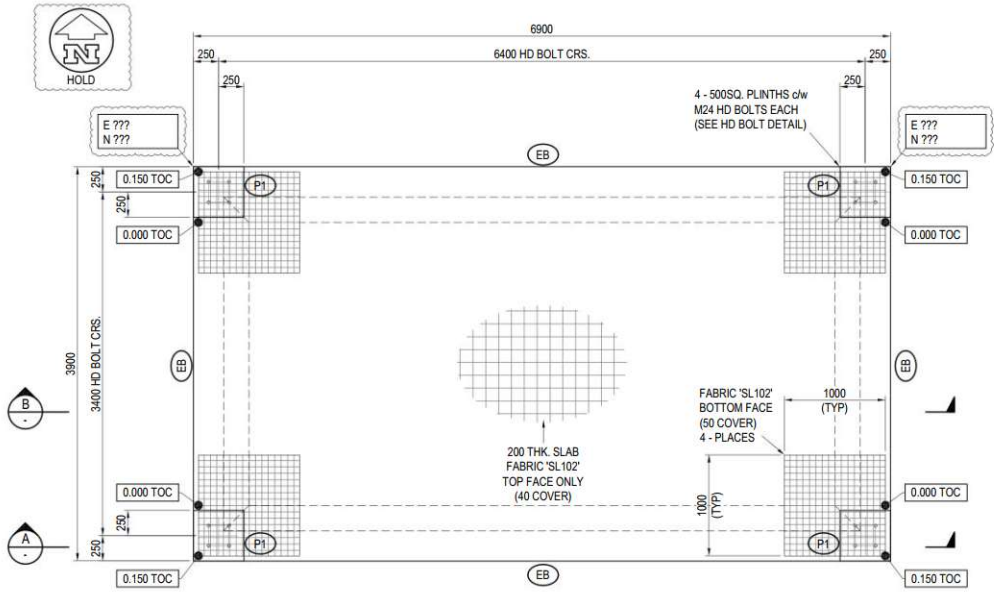

PLAN ON VALVE STATION SLAB
(SCALE 1:25)

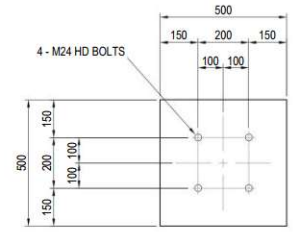

PLAN ON PLINTH (P1)

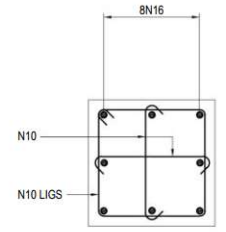

PLAN ON PLINTH (P1)

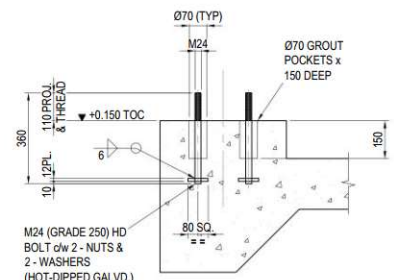

PLINTH (P1) (4 OFF)
SCALE 1:10

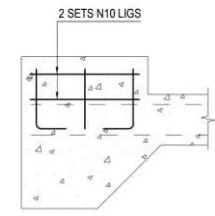

PLINTH (P1) (4 OFF)
SCALE 1:10

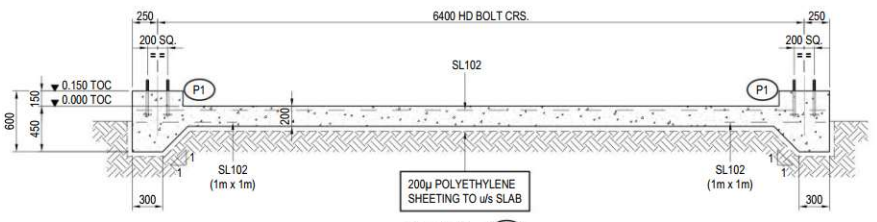

SECTION A-A
SCALE 1:25

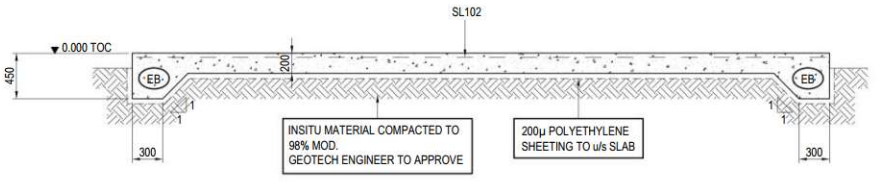

SECTION B-B
SCALE 1:25

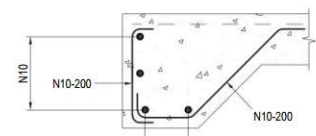

EDGE BEAM (EB)
SCALE 1:10

DATUM 0.000 = RL ???

ISSUED FOR REVIEW
NOT FOR CONSTRUCTION

- CONCRETE NOTES
- COVER (UON): 50mm
 - CONCRETE: S32
 - REQ: TYPE 'N' DEFORMED BAR (GRADE 500mPa)

FRASER-LEVER
CONSULTING ENGINEERS
PH: +61 7 3162 3000
VIC: fraserlever.com.au
EMAIL: admin@fraserlever.com.au



DESIGNED			
DRAWN			
CHECKED			
APPROVED			
INITIAL	SIGNAT	DATE	
SCALE	1:25	DRAWING NO.	PE1240-00-CC002-CC-DRG001

CENTRAL HIGHLANDS REGIONAL COUNCIL
BLACKWATER RECYCLE WATER PIPELINE
BOUNDARY VALVE STATION
GENERAL ARRANGEMENT & DETAILS - CIVILS

REV. A

REFERENCE DWG. NO.	REFERENCE DESCRIPTION	REV	BY	DATE	ISSUE FOR INFORMATION	DFH	DFH
				15.06.2025			
					REVISION DESCRIPTION	CHK	ENG

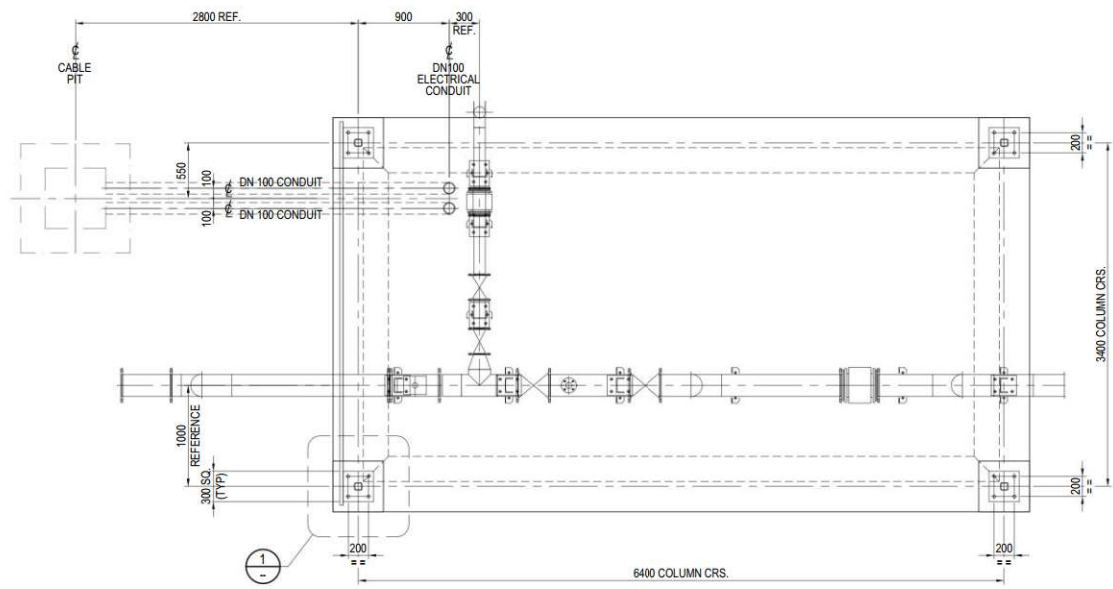

- NOTES**
- ALL HOLLOW SECTION MATERIAL : GRADE 350MPa
 - ALL PLATEWORK : GRADE 300MPa
 - ALL PLATES TO BE 10mm THICK UON
 - ALL WELDS : 6mm CFW
 - ALL BOLTS : M20 (GRADE 8.8) UON

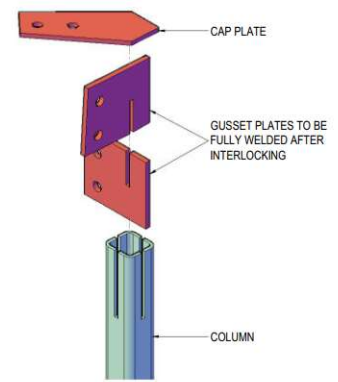

EXPLODED VIEW SHOWING CRUCIFORM ASSEMBLY (TYPICAL GUSSETS & CAP PLATE PER COLUMN)

DETAIL 1
SCALE 1:10

PLAN
SCALE 1:25

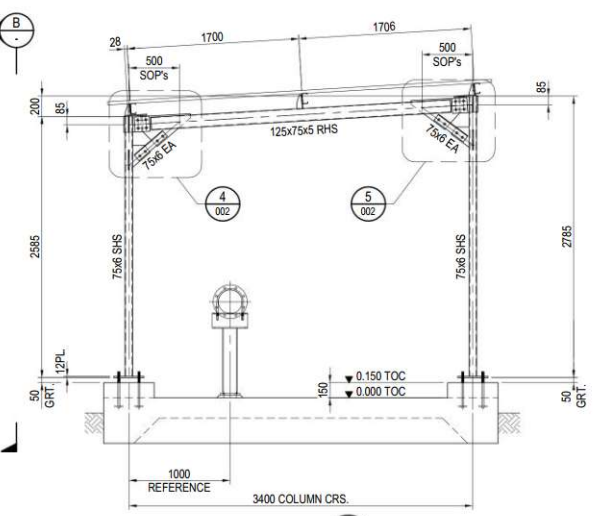
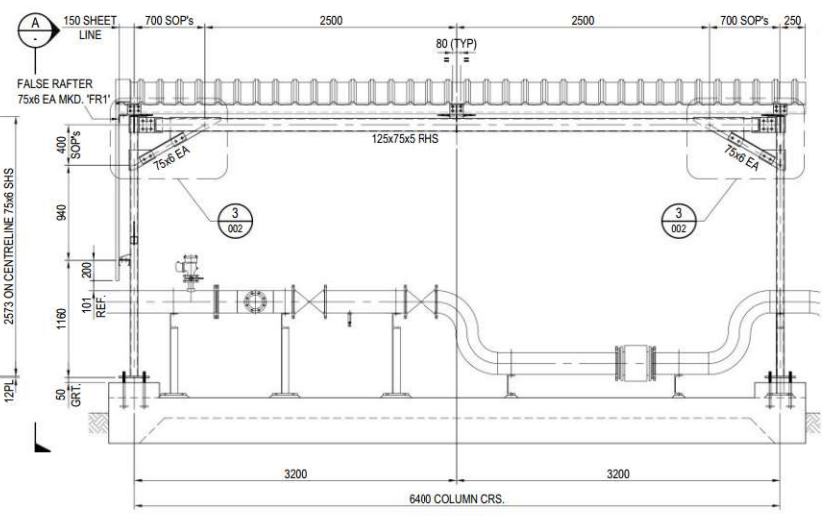
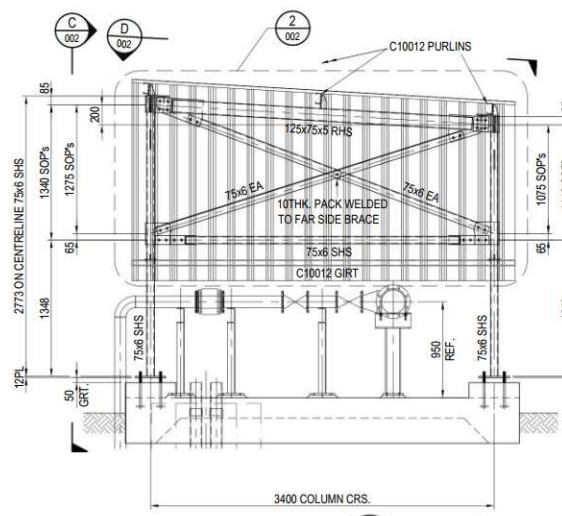

ISSUED FOR REVIEW NOT FOR CONSTRUCTION

FRASER LEVER
CONSULTING ENGINEERS
PH: +61 7 3362 3800 VC: fraserlever.com.au
EMAIL: admin@fraserlever.com.au



DESIGNED	
DRAWN	
CHECKED	
APPROVED	
INITIAL	SIGNAT
DATE	
SCALE	1:25

CENTRAL HIGHLANDS REGIONAL COUNCIL
BLACKWATER RECYCLE WATER PIPELINE
PURPLE TANK VALVE STATION
GENERAL ARRANGEMENT & DETAILS (SHEET 1 OF 2)

DRAWING NO. PE1240-00-ST001-ST-DRG001

REV. A

REV	BY	DATE	ISSUE FOR INFORMATION	REVISION DESCRIPTION	CHK	ENG	APP
A	FT	15.06.2025	ISSUE FOR INFORMATION		DFH	DFH	

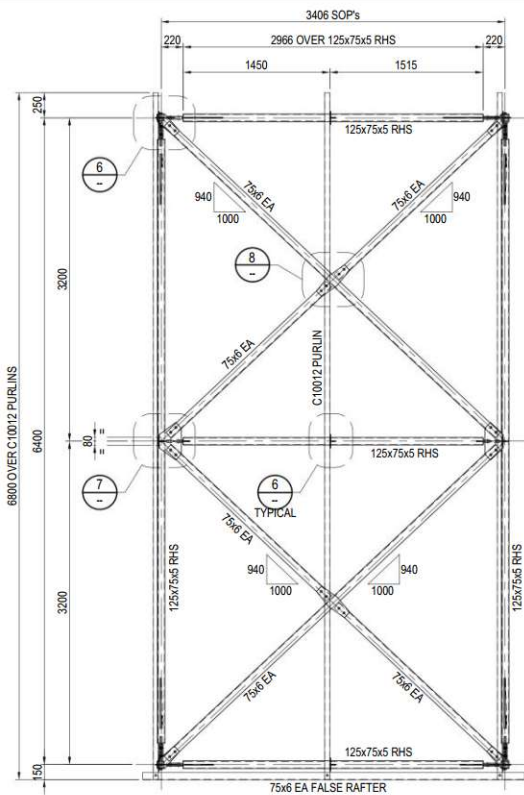

PLAN
SCALE 1:25
001

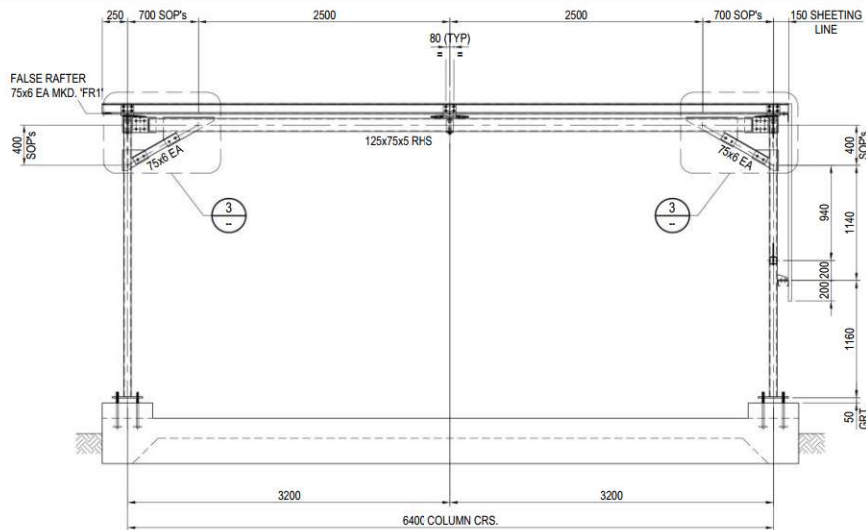

VIEW ON C
SCALE 1:25
001

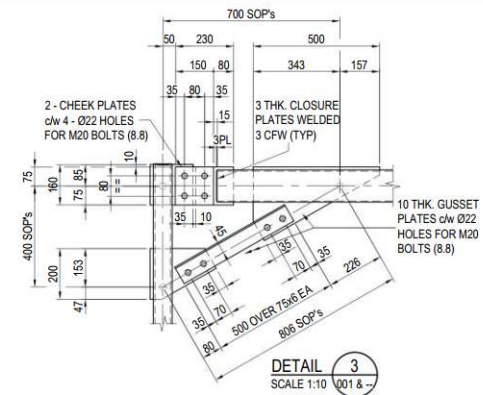

DETAIL 3
SCALE 1:10
001 & -

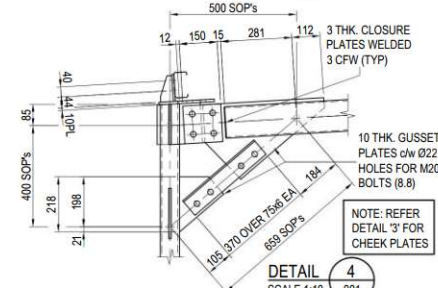

DETAIL 4
SCALE 1:10
001

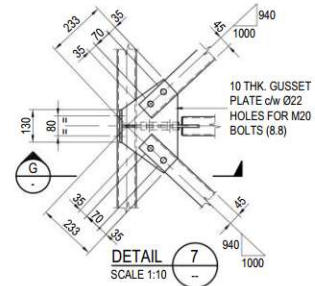

DETAIL 7
SCALE 1:10
-

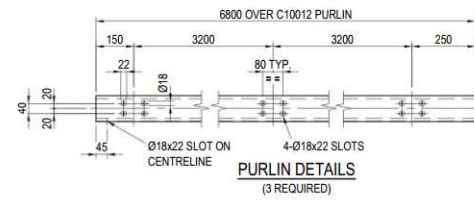

PURLIN DETAILS
(3 REQUIRED)

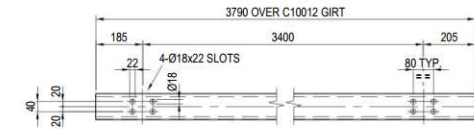

GIRT DETAILS
(1 REQUIRED)

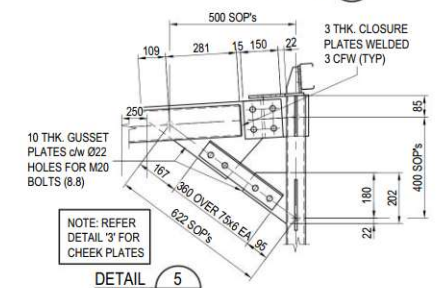

DETAIL 5
SCALE 1:10
001

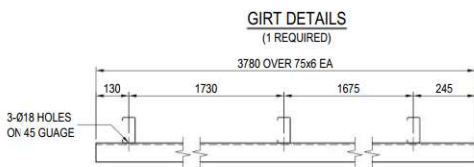

FALSE RAFTER DETAILS
(1 REQUIRED)

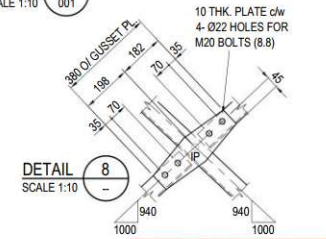

DETAIL 8
SCALE 1:10
-

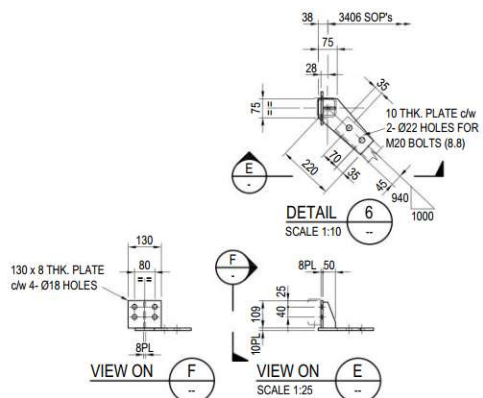

DETAIL 6
SCALE 1:10
-

VIEW ON F
SCALE 1:25
-

VIEW ON E
SCALE 1:25
-

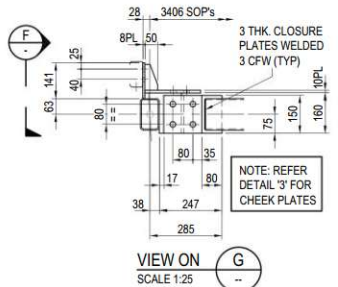

VIEW ON G
SCALE 1:25
-

FRASER LEVER
CONSULTING ENGINEERS
PH: +61 7 3162 3800 VC: fraserlever.com.au
EMAIL: admin@fraserlever.com.au



DESIGNED		
DRAWN		
CHECKED		
APPROVED		
INITIAL	SIGNAT	DATE
SCALE	1:25	DRAWING NO.

CENTRAL HIGHLANDS REGIONAL COUNCIL
BLACKWATER RECYCLE WATER PIPELINE
PURPLE TANK VALVE STATION
GENERAL ARRANGEMENT & DETAILS (SHEET 2 OF 2)
PE1240-00-ST001-ST-DRG002

ISSUED FOR REVIEW
NOT FOR CONSTRUCTION

REFERENCE DWG. NO.	REFERENCE DESCRIPTION	REV	BY	DATE	ISSUE FOR INFORMATION	REVISION DESCRIPTION	CHK	ENG	APP
				15.06.2025			DFH	DFH	

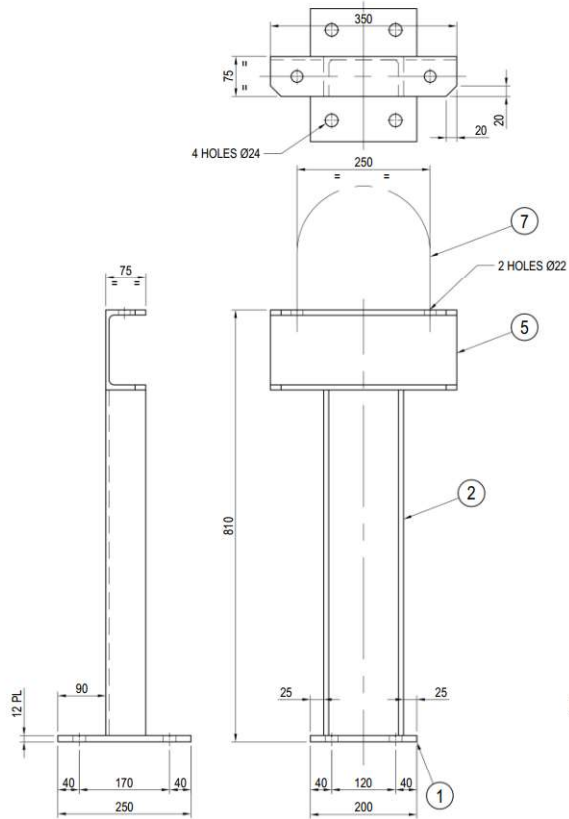

PIPE SUPPORT PS2
-4 REQ'D.
SCALE 1:5

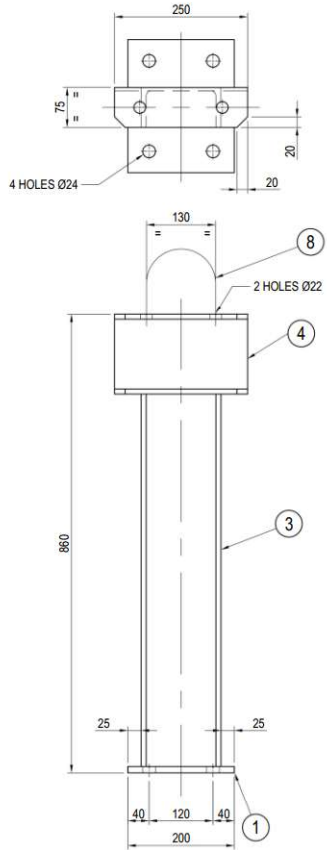

PIPE SUPPORT PS3
-3 REQ'D.
SCALE 1:5

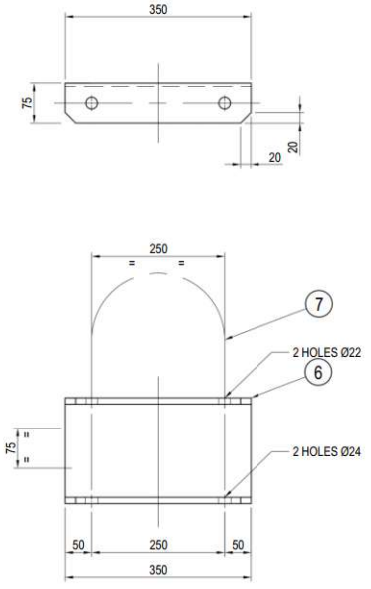

PIPE SUPPORT PS4
-2 REQ'D.
SCALE 1:5

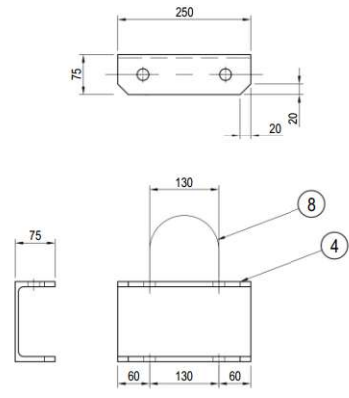

PIPE SUPPORT PS5
-1 REQ'D.
SCALE 1:5

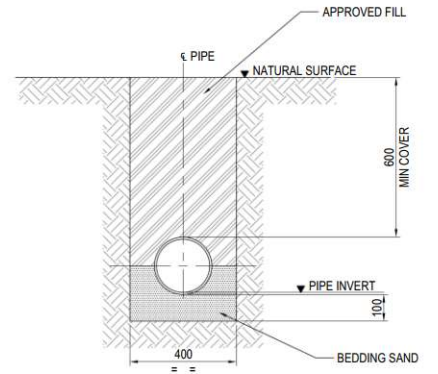

TYPICAL TRENCH DETAIL FOR DN200 SS PIPE
SCALE 1:10

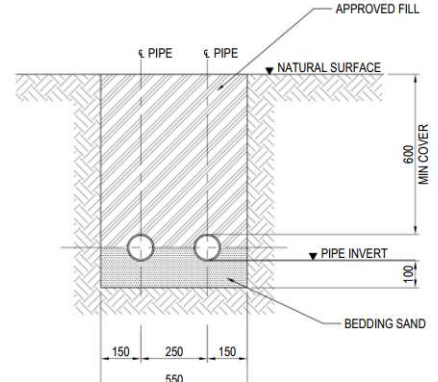

TYPICAL TRENCH DETAIL FOR 2x 100 LV & COMMS. CONDUITS
SCALE 1:10

NOTES:
1. PIPE SUPPORTS TO BE MILD STEEL HOT DIP GALVANISED.

ITEM	QTY	DESCRIPTION	LENGTH	REMARKS
8	4	U-BOLT SUIT DN100 PIPE GALV.	-	-
7	6	U-BOLT SUIT DN200 PIPE GALV.	-	-
6	4	CHANNEL 200PFC, MS, 300+	350	-
5	4	CHANNEL 150PFC, MS, 300+	350	-
4	4	CHANNEL 150PFC, MS, 300+	250	-
3	3	CHANNEL 150PFC, MS, 300+	698	-
2	4	CHANNEL 150PFC, MS, 300+	648	-
1	7	FLAT BAR, 200 x 12 MS 250	250	-

ISSUED FOR
PRELIMINARY
NOT FOR CONSTRUCTION

REV	BY	DATE	REVISION DESCRIPTION	CHK	ENG	APP
B	QC	24.06.25	ADDED PIPE SUPPORT PS5			
KF	10.06.2025		ISSUE FOR INFORMATION	GC	QC	

FRASER-LEVER
CONSULTING ENGINEERS
PO BOX 1000
PO BOX 1000
PO BOX 1000
PO BOX 1000



DESIGNED	DRAWN	CHECKED	APPROVED
INITIAL	CHK/AT	DATE	

CENTRAL HIGHLANDS REGIONAL COUNCIL
BLACKWATER RECYCLE WATER PIPELINE
PURPLE TANK VALVE STATION - STAGE 2
DETAILS SHEET 2 OF 2

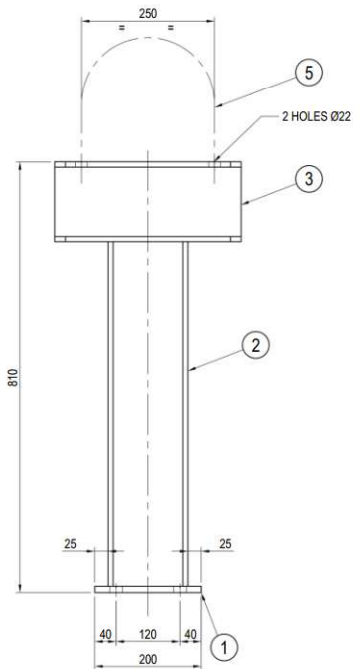
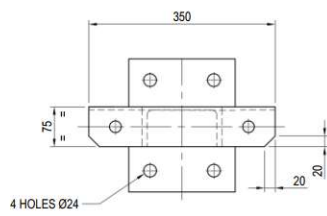

PIPE SUPPORT PS2
-3 REQD.
SCALE 1:5

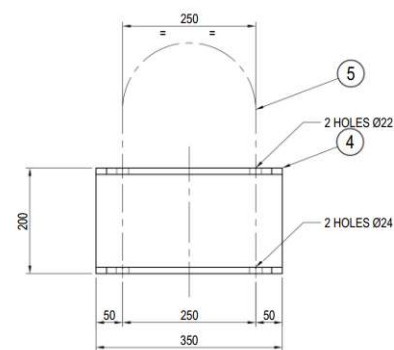
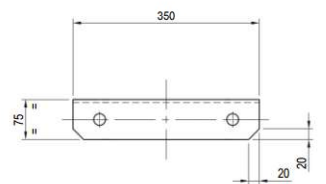

PIPE SUPPORT PS4
-2 REQD.
SCALE 1:5

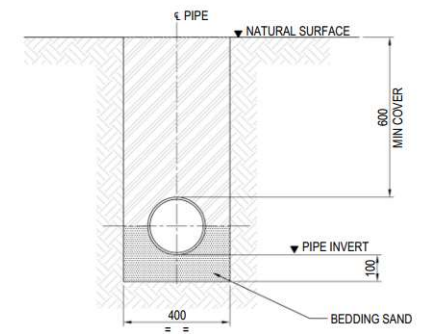

TYPICAL TRENCH DETAIL FOR DN200 SS PIPE
SCALE 1:10

- NOTES:
1. PIPE SUPPORTS TO BE MILD STEEL HOT DIP GALVANISED.

ITEM	QTY	DESCRIPTION	LENGTH	REMARKS
5	6	U-BOLT SUIT DN200 PIPE GALV.	-	-
4	4	CHANNEL 200PFC, MS, 300+	350	-
3	4	CHANNEL 150PFC, MS, 300+	350	-
2	4	CHANNEL 150PFC, MS, 300+	648	-
1	7	FLAT BAR, 200 x 12 MS 250	250	-

ISSUED FOR
PRELIMINARY
NOT FOR CONSTRUCTION

REVISION	NO.	DATE	BY	DESCRIPTION	CHK	ENG	APP
A	KF	10.06.2025		ISSUE FOR INFORMATION	GC	GC	

FRASER-LEVER
CONSULTING ENGINEERS
PO BOX 1000
PO BOX 1000
PO BOX 1000
PO BOX 1000



DESIGNED				CENTRAL HIGHLANDS REGIONAL COUNCIL BLACKWATER RECYCLE WATER PIPELINE BOUNDARY VALVE STATION DETAILS SHEET 2 OF 2
DRAWN				
CHECKED				
APPROVED				
SCALE	1:10	DRAWING NO.	PE1240-A3-PI001-PI-DRG020	REV. A