

Site Classification Report

Prepared for Leroy Palmer Consulting Engineers
30 June 2019

Proposed Residence
6 Lowe Court, Top Camp

Job No. ST20319



ABOUT YOUR SITE INVESTIGATION REPORT

The Site Investigation report aims to assign a single “Site Classification” to the intended building site. This Site Classification gives an indication of the expected amount of movement of the soils across the intended building site, which indicates the reactivity of the soils in that particular location.

All on-site features as well as the climatic conditions need to be taken into consideration when a Site Classification is assigned. These factors can have an effect on the extent of soil movement and differential effects over the area.

The Site Classification concerns the site as a whole, and not just the reactivity of the soil.

The soils on the Darling Downs and surrounding areas are quite variable and include rock, sands, sandy clays and clays with varying expansive properties. The more expansive soils are well known to exhibit moderate to extreme movements depending on where the site is located. Soil movement occurs two ways:

- 1. SWELL – occurs when clay layers absorb moisture into their structure and expand**
- 2. SHRINK – occurs when they dry out and these clay layers lose moisture**

The degree of such movement is affected by the types and proportions of clay minerals present.

CLASS P sites are those sites that may contain some of the features described in the table on page 2. The “P” Classification acts as a “warning bell” to the footing/slab designer that particular site feature/s need to be considered when designing the footings. These features may cause abnormal conditions in the underlying soils that will adversely affect the expected amount of soil movement that would occur under normal conditions.

“P” sites may not necessarily be “Bad Sites”, i.e. particularly reactive or expensive to build on, depending on the assessment of the Footing Designer. Such an assessment may conclude that the influence of the “Feature” is either minor (or even negligible), or significant enough to warrant specific design. If the on-site factors are negligible then standard footings may be designed but if it is more severe then design by Engineering Principles may be required. Additional requirements for footings, which often result, can add some cost to building construction.

Incorrect classification can lead to building distress and damage, and it is therefore imperative that the site be investigated thoroughly, and classified appropriately.

AS2870-2011 is the Australian Standard that deals with Site Classification and Residential Footing Design. The standard designates a Site Classification that is appropriate to the expected amount of movement at the surface under normal conditions. The standard then designates standard footings for this classification. It also designates a “P” Classification under abnormal site conditions and depending on the severity of the feature/s, standard footings (from the building code) or Engineer-designed footings may be applied.

Class	Expected Surface Movement (Y_s)	Explanation
A	0mm	Includes many sand, gravel and rock sites with no clays. These sites have no expected movement and as a result zero moisture variation.
S	0 - 20mm	SLIGHTLY reactive sites which exhibit only small movements with moisture variation.
M	20 - 40mm	MODERATELY reactive sites exhibit moderate amounts of movement with moisture variation. These sites commonly include red/brown silty soils, some sandy clays and loamy soils.
H1	40 - 60mm	HIGHLY reactive sites exhibit high amounts of movement with moisture variation. These sites include some silty clays in the Toowoomba area and many of the sandy clays and basaltic clays in the Lockyer Valley.
H2	60 - 75mm	HIGHLY reactive sites exhibit very high amounts of movement with moisture variation. These sites include some silty clays in the Toowoomba area and many of the sandy clays and basaltic clays in the Lockyer Valley.
E	>75mm	EXTREMELY reactive sites which exhibit greater than 75mm of surface movement. Typically, these sites include deep reactive clays, such as black and dark brown soils on the Darling Downs, but are also found throughout the Lockyer Valley and parts of Toowoomba. These sites typically demand quite expensive footing systems.
P	<p>As indicated previously, the Site Classification must consider many aspects of the site, not just the reactivity of the soil. P sites are those that include other factors that need to be brought to the attention of the owner, builder and footing designer. A “P” classification does not indicate a specific Y_s value and is described as a “Problem” site.</p> <p>The reasons for a P classification include:</p> <ul style="list-style-type: none"> • Growth &/or Removal of Trees will cause Abnormal moisture conditions in the subsurface soils; • Unusually high moisture conditions caused by water flow, ponds, dams etc; • Sites with fill which can be either “controlled” or “uncontrolled”. The P Classification depends upon the depth and type of fill; • Sites with poor bearing capacity, soft soils, or soils which are prone to collapse; • Sites prone to mine subsidence, land slip, piping or coastal erosion; • Sites which for one reason or another cannot be classified as normal sites; 	

ST20319 pgs;km
30 June, 2019

Leroy Palmer Consulting Engineers
PO Box 1413
Toowoomba Qld 4350

Dear Matt,

SITE CLASSIFICATION REPORT

6 Lowe Court, Top Camp

1.0 GENERAL

As requested, a site classification for a new building was carried out at 6 Lowe Court, Top Camp on the 25 June, 2019. The purpose of this investigation was to provide data on the site conditions and soil characteristics at this location with particular interest on the potential of the underlying soils to exhibit swell/shrink characteristics under varying moisture conditions.

2.0 SITE CLASSIFICATION

Site Classification:

P (Ys 75 - 85mm, E range excluding trees)

Special Considerations:

- 1. This is a P site due to trees. Trees may cause abnormal moisture conditions in the underlying soils.**
- 2. This is a P site due to Fill. Uncontrolled fill may have abnormal moisture conditions and consolidation problems.**

3.0 SITE INVESTIGATION

The site investigation consisted of 4 boreholes excavated on-site down to 2500mm and 4000mm (as shown on the borelogs in Appendix 1) using a 100mm diameter hydraulic auger. These boreholes were located as per the site plan and the various site details are recorded on the Site Map in Appendix 1 and the attached photos. There appears to be little to no fall across the site and provided an appropriate platform height is selected, there should be no problems with site drainage.

Numerous disturbed samples were collected from each borehole and hand classified on-site. The subsequent soil profiles with the appropriate Unified Soil Classification (USC) of each soil layer are shown on the borelogs in Appendix 1. Three disturbed samples were collected, sealed and returned to the laboratory for testing of moisture content on all samples and Linear Shrinkage characteristics on appropriate samples. No undisturbed samples were taken for Shrink Swell testing due to the nature of the material, however a detailed database of correlated results between Atterberg Limits and Shrink Swells has been used to estimate realistic I_{ss} values as per AS2870-2001 2.3.2 (ii).

We have endeavoured to locate the boreholes so that they are representative of the soil conditions across the intended building site. The client should be aware that soil conditions could change dramatically over short distances so that even carefully planned investigations may not locate all soil variations across the site. Also, an accurate assessment to determine if fill material exists on-site along with the depth of any existing fill material may be difficult due to the use of natural soils for fill which may be hard to distinguish from natural soil profiles. If any excavations reveal different soils than those shown on the borelogs in Appendix 1, the Foundation Designer should be notified and more testing should be carried out.

NOTE: Any dimensions, slope directions or magnitudes, shown on the Site Map are estimates only and should not be used for any building cost calculations.

4.0 LABORATORY TESTING

After field assessment of the materials obtained on site, selected samples were returned to our laboratory for the determination of both moisture content and Linear Shrinkage of the soil. The results of this testing, as well as the results of any other relevant testing are shown on the borelogs in Appendix 1.

5.0 RESULTS & CONCLUSIONS

We have examined the soil profiles from all boreholes and taken into account the relevant site conditions and details. We have then classified the site **P**.

Excluding the effects of trees, rocks (which may cause abnormal moisture conditions within the underlying soils) and future earthworks, we expect a characteristic surface movement, **Y_s**, of **75 - 85mm** (refer to AS2870 – Section 2). This **Y_s** value is representative of the site under normal soil conditions only and the designer should give due consideration to the effects of the existing abnormal moisture conditions on the foundation design.

Field classification and laboratory testing of the returned materials indicate that the underlying soils have an **Extreme** potential to swell/shrink under varying moisture conditions. This swelling &/or shrinking of the soils is attributed to the absorption &/or loss of moisture and may cause structural damage to a building unless appropriate design procedures are followed.

No water table was encountered during our investigation. Should subsequent observations or excavations encounter this problem, the Foundation Designer should be contacted immediately.

We note that pocket penetrometer readings and the rate of drilling indicates that this site has an allowable bearing pressure equal to or greater than 100kPa over the full depth of both boreholes (excluding any fill material). The depths of the proposed footings were unknown at the time of the investigation.

6.0 RECOMMENDATIONS

6.1 Design

Foundation designs should be carried out in accordance with the procedures outlined in AS2870 – 2011 for normal domestic construction. For commercial buildings, design by a suitably qualified engineer is recommended. The foundation designs are dependent upon the floor plan and type of construction proposed for a particular building. Should the proposed construction details change in any way after a foundation design is issued, the foundation designer should be notified immediately prior to these changes being carried out.

The footing system should be designed (for normal residential construction) to the performance level outlined in AS2870 – 2011, Clause 1.3.1, such that it should experience:

- Usually no damage;
- A low incidence of Category 1 damage;
- An occasional incidence of Category 2 damage.

All excavation and construction of foundations should be carried out in accordance with the procedures outlined in AS2870 – 2011 as a minimum standard, engineering design for commercial buildings is recommended. For reactive clay sites such as **H** and **E** sites, the designer should also pay attention to clauses 5.5 and 6.6.

All brickwork must have full height articulation at a maximum spacing of 4.8 metres (as measured from articulation point to articulation point, including "around corner" measurements). It may be necessary to use expansion joints in the brickwork to facilitate this articulation. Where expansion joints are used, this must be done in an approved manner. Methods of articulation are well documented, and Construction Note TN61 by the Cement and Concrete Association of Australia (October 1991) clearly outlines these procedures. Termite protection should also be carried out in accordance with AS3660.1 – 1995.

We found that small to large trees exist on and/or near the intended building site and it is likely that the proposed building may be located within the zone of influence of the root systems of these trees. CSIRO publication 10-91 (attached) gives recommendations on clearances between trees and footing positions for the appropriate site classification.

It is not possible to predict the effect of trees on a footing system, however the potential still exists for trees to affect the performance of a footing system. If trees occur within the zone of influence of the proposed construction, adequate precautions must be taken to ensure minimal variations to the subsurface moisture conditions across the building site. This may be done by:

1. Adequate site maintenance - watering of soils near the trees during periods of dry weather.
2. Design and install the approved root inhibiting measures to ensure the tree root system does not affect the footing design.

The site classification in this report makes no allowance for the effects of these trees

6.2 Site Earthworks

All site earthworks should be carried out in accordance with the procedures outlined in AS3798 – 2007. Brief notes and recommendations on Site Earthworks are shown in Appendix 2.

AS3798 – 2007 recommends that before any construction work is attempted, each building site should be scraped free of all significant organic material and debris. If cut and fill is required then the fill should be clean spoil recovered from the site cut and laid down in 150mm (maximum) layers. Each layer should be moistened and compacted using suitable compaction equipment to a minimum 95% standard compaction. Each 300mm layer should be tested in accordance with AS1289.5.3.1, 5.4.1 or 5.8.1, 5.4.1.

We advise the client and builder that there has been fill placed on the intended building site. We recommend that before construction begins, this area should be checked for 'soft-spots' by proof-rolling. If any 'soft-spots' are found these should be excavated and re-compacted using the procedures outlined in Clause 6.2. 'Soft-spots' may cause consolidation problems if they are not repaired.

Should compaction testing be required, Soiltech Testing Services can be engaged to carry out compaction density testing on the platform during construction of the building pad.

If site conditions change after the initial soil test has been carried out then there may be a need to reclassify the site. Typical examples of changes in site conditions include:

- **Cutting and filling to create a platform**
- **Filling to create a building platform**
- **Changing the house location from where the original soil test took place**

NOTE: These recommendations are only guidelines and are not site specific. Soiltech should be consulted about specific earthworks to be undertaken on your site, BEFORE SITE EARTHWORKS BEGIN, so that a suitable outcome may be achieved.

6.3 Drainage

Drainage of building sites should be carried out in accordance with the procedures outlined in AS2870 – 2011 clause 5.2. Recommended drainage patterns are outlined in Appendix 3.

Finished surface levels around the buildings should be such that all stormwater is directed away from the building so as to prevent ponding of any water against the building foundations. All water should be directed to at least 3m away from the building.

It is very important on all construction sites that the correct drainage be maintained both during construction and upon completion.

6.4 Services

In all clay soils, we recommend that service pipes/trenches not be located within the zone of influence of the foundations. It is recommended that they be placed no closer than 1m from the foundations and all trenches should slope away from the building. To avoid water leakage to the foundations, ensure that all trenches are backfilled with clay in the top 300mm.

If service pipes/trenches must penetrate the foundation system, please ensure that all pipes have flexible joints and the trenches are backfilled with clay to reduce the risk of leakage of water to the foundations.

It is recommended that the discharge pipes from hot water systems and pressure relief valves be piped or directed away from the buildings to a gully trap or approved stormwater system. This should be directed to an approved outlet at least 3m downhill and away from the foundations.

6.5 Post Construction Recommendations

It is preferable in the case of a slab on ground that a 1m concrete path be constructed around the perimeter of the footings with falls away from the building and sealed against the building.

Trees or dense shrubs should not be grown against the building as they create abnormal moisture conditions in the underlying soil. This may cause differential movement across the site and hence cause structural damage. A copy of the publication CSIRO Information Services Sheet No 10-91 (April 1995) – Guide to Home Owners on Foundation Maintenance and Footing Performance has been enclosed and provides information on safe distances for the growth of trees and dense shrubs.

The Site Classification supplied in this report assumes that adequate site maintenance is carried out by the owner/occupier. If large trees exist or are planted in the vicinity of the building, it may be necessary to install measures to control the effect of these in the early stages of their development and before maturity so as to minimise their effect on footing performance.

7.0 NON-STRUCTURAL CRACKING

7.1 Direct Tension Slab Cracking due to Concrete Shrinkage

Owing to the variability of concrete as a building product and conditions existing at the time of pour, it is not possible to provide any guarantee against shrinkage cracking in concrete slabs. Shrinkage cracking may occur in all concrete and to provide sufficient steel to eliminate this problem is uneconomic.

7.2 Growth Cracking in Brickwork

This phenomenon is caused by the absorption of moisture into the brick structure causing gradual expansion of the brickwork itself. This may lead to minor vertical cracking, generally located near the corners of the building.

7.3 Timber Shrinkage

Timber Shrinkage arises from the use of timber framing (particularly unseasoned hardwood) and can lead to cracking in linings etc. This is usually corrected at the time of repainting.

We thank you for using our services. Should you require any further assistance, or need any more information with regard to the above report, please do not hesitate to contact our office. Should you have any enquires, they can be directed to Paul Sheppard.

Yours faithfully



Paul Sheppard
Managing Director
QBCC Site Classifier Number: 1096245



Depth (mm)	Logged By: Mike Seefeld - Date: 25/06/19 MATERIAL DESCRIPTION	FILL	CLASSIFICATION SYMBOL	ESTIMATED I _{ss} %	COLOUR	MOISTURE CONTENT	CONSISTENCY	DCP (Blows per 100mm)	SAMPLE (D/BD/UD)	Standard Penetration Test (SPT)	Soaked CBR (%)	Moisture Content (%)	Linear Shrinkage (%)	Liquid Limit (%)
100	Silty CLAY with a trace of gravel		CH	3.5	Darkish brown	Moist/dry	Stiff	4						
200														
300														
400														
500														
600														
700														
800														
900														
1000														
1100														
1200														
1300														
1400														
1500														
1600														
1700														
1800														
1900														
2000														
2100														
2200														
2300														
2400														
2500														
2600														
2700														
2800	Silty CLAY with a trace of sand/ gravel		CH	3.0	Dark brown	Dry	Stiff							
2900														
3000														
3100	Silty CLAY with a trace of weathered basalt		CH	4.0	Very dark brown	Moist	Stiff					31.7	21.5	83.8
3200														
3300														
3400														
3500														
3600														
3700	Silty CLAY with a trace of sand (weathered basalt)		CH	2.0	Dark yellow grey brown mottled orange	Moist/dry	Stiff/very stiff							
3800														
3900														
4000														

Hole Terminated at 4000 mm



Depth (mm)	Logged By: Mike Seefeld - Date: 25/06/19 MATERIAL DESCRIPTION	FILL	CLASSIFICATION SYMBOL	ESTIMATED I _{ss} %	COLOUR	MOISTURE CONTENT	CONSISTENCY	DCP (Blows per 100mm)	SAMPLE (D/BD/UD)	Standard Penetration Test (SPT)	Soaked CBR (%)	Moisture Content (%)	Linear Shrinkage (%)	Liquid Limit (%)
100	Silty CLAY with a trace of gravel		CH	3.5	Darkish brown	Moist/dry	Stiff	5						
200														
300														
400														
500														
600														
700														
800														
900														
1000														
1100														
1200														
1300														
1400														
1500														
1600	Silty CLAY with a trace of weathered basalt		CH	4.0	Very dark brown	Moist	Stiff							
1700														
1800														
1900														
2000														
2100														
2200														
2300														
2400														
2500	Silty CLAY with a trace of weathered basalt		CH	3.5	Dark brown	Moist	Stiff							
2600	Hole Terminated at 2500 mm - Target Depth													
2700														
2800														
2900														
3000														
3100														
3200														
3300														
3400														
3500														
3600														
3700														
3800														
3900														
4000														

SITE SKETCH

JOB ADDRESS: 6 Lowe Court - TOP CAMP

CLIENT: Leroy Palmer Consulting Engineers

STS JOB NUMBER: ST20319

REPORT DATE: 30/06/19

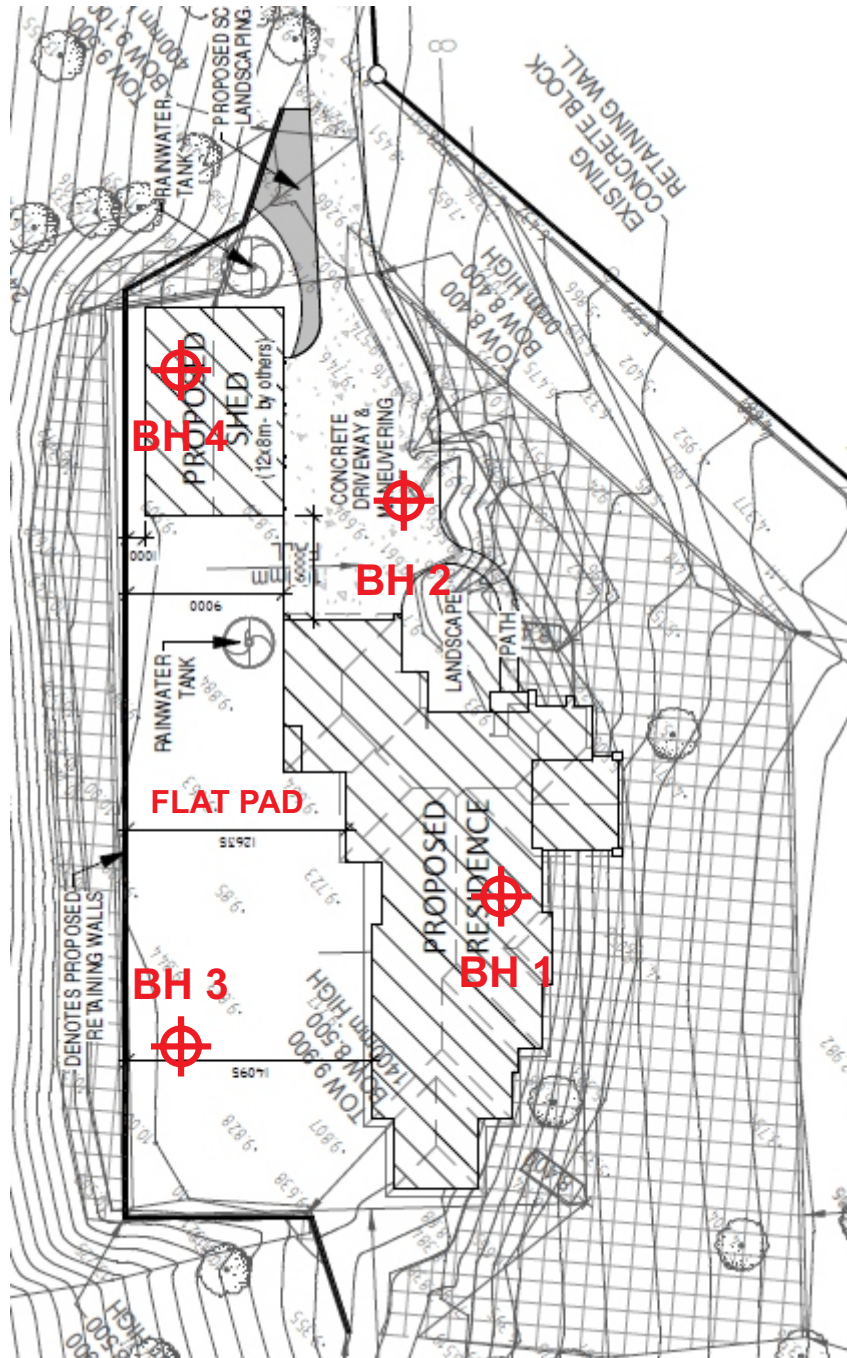



SOILTECH
Testing Services Pty Ltd
1300 736 724
www.soiltech.com.au

SITE PHOTOS

JOB ADDRESS: 6 Lowe Court, TOP CAMP

CLIENT: Leroy Palmer Consulting Engineers

STS JOB NUMBER: ST20319

REPORT DATE: 30/06/19





SOILTECH
Testing Services Pty Ltd
1300 736 724
www.soiltech.com.au

SITE PHOTOS

JOB ADDRESS: 6 Lowe Court, TOP CAMP

CLIENT: Leroy Palmer Consulting Engineers

STS JOB NUMBER: ST20319

REPORT DATE: 30/06/19





SOILTECH
Testing Services Pty Ltd
1300 736 724
www.soiltech.com.au

SITE PHOTOS

JOB ADDRESS: 6 Lowe Court, TOP CAMP

CLIENT: Leroy Palmer Consulting Engineers

STS JOB NUMBER: ST20319

REPORT DATE: 30/06/19



APPENDIX 2

SITE EARTHWORKS

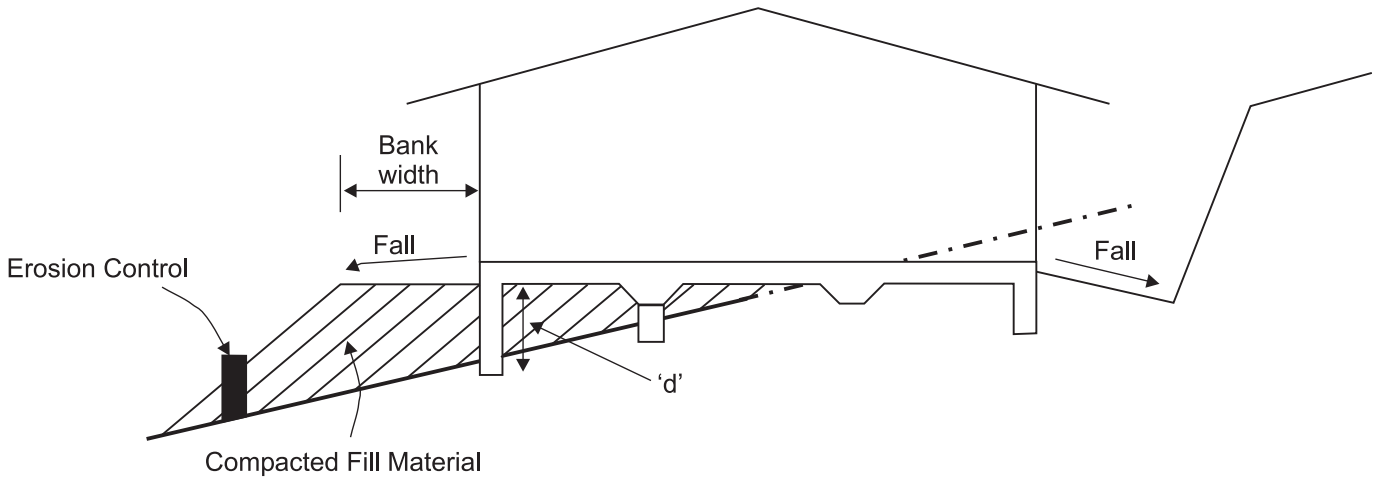

NOTES:

1. Bank Width - 1800mm or:
 - (a) 1.5d for Weathered Rock or well graded Granular fill:
 - (b) 2.0d for Clays or silty, sandy and gravelly Clays: Silts,
 - (c) 3.0d for sands and soft Clays.
2. Where the specified Bank Width above cannot be achieved, an Engineer should be consulted for a Retaining Wall &/or Pier Design.
3. All organic matter should be removed from the intended building site prior to construction of the foundations.
4. If any trees are removed to be removed, the grubholes shall be backfilled and compacted according to Note 5.
5. Any material used as fill underneath the intended building shall be built up in layers of 150mm moistened and compacted with suitable compaction equipment to 95% Standard Compaction in accordance with AS 3790.

APPENDIX 3

SITE DRAINAGE

TYPICAL DRAINAGE LAYOUTS

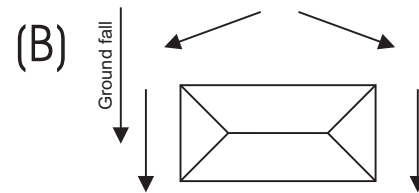
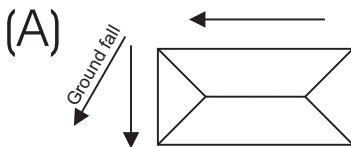

TYPICAL DRAINAGE LAYOUT FOR CUT/FILL SITES

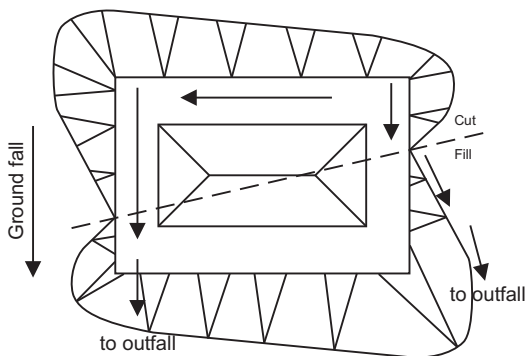

TYPICAL DRAINAGE LAYOUT FOR WET SITES

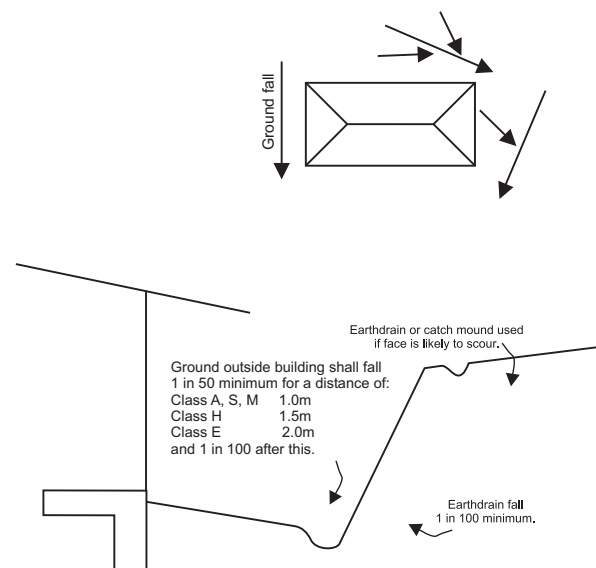

NOTES:

1. It is extremely important to maintain good drainage throughout constructions of any building
2. Fall away from the building shall be 50mm for the first metre so water does not pond against or near the building
3. All water run-off shall be channeled away from the building at all times pre & post construction
4. For flat sites, an Engineer should be consulted to ensure that the finished height of the building allows proper drainage away from the building
5. Drainage must not direct water to adjacent blocks in a concentrated form

Foundation Maintenance and Footing Performance: A Homeowner's Guide



PUBLISHING
BTF 18-2011
replaces
Information
Sheet 10/91

Buildings can and often do move. This movement can be up, down, lateral or rotational. The fundamental cause of movement in buildings can usually be related to one or more problems in the foundation soil. It is important for the homeowner to identify the soil type in order to ascertain the measures that should be put in place in order to ensure that problems in the foundation soil can be prevented, thus protecting against building movement.

This Building Technology File is designed to identify causes of soil-related building movement, and to suggest methods of prevention of resultant cracking in buildings.

Soil Types

The types of soils usually present under the topsoil in land zoned for residential buildings can be split into two approximate groups – granular and clay. Quite often, foundation soil is a mixture of both types. The general problems associated with soils having granular content are usually caused by erosion. Clay soils are subject to saturation and swell/shrink problems.

Classifications for a given area can generally be obtained by application to the local authority, but these are sometimes unreliable and if there is doubt, a geotechnical report should be commissioned. As most buildings suffering movement problems are founded on clay soils, there is an emphasis on classification of soils according to the amount of swell and shrinkage they experience with variations of water content. The table below is Table 2.1 from AS 2870-2011, the Residential Slab and Footing Code.

Causes of Movement

Settlement due to construction

There are two types of settlement that occur as a result of construction:

- Immediate settlement occurs when a building is first placed on its foundation soil, as a result of compaction of the soil under the weight of the structure. The cohesive quality of clay soil mitigates against this, but granular (particularly sandy) soil is susceptible.
- Consolidation settlement is a feature of clay soil and may take place because of the expulsion of moisture from the soil or because of the soil's lack of resistance to local compressive or shear stresses. This will usually take place during the first few months after construction, but has been known to take many years in exceptional cases.

These problems are the province of the builder and should be taken into consideration as part of the preparation of the site for construction. Building Technology File 19 (BTF 19) deals with these problems.

Erosion

All soils are prone to erosion, but sandy soil is particularly susceptible to being washed away. Even clay with a sand component of say 10% or more can suffer from erosion.

Saturation

This is particularly a problem in clay soils. Saturation creates a bog-like suspension of the soil that causes it to lose virtually all of its bearing capacity. To a lesser degree, sand is affected by saturation because saturated sand may undergo a reduction in volume, particularly imported sand fill for bedding and blinding layers. However, this usually occurs as immediate settlement and should normally be the province of the builder.

Seasonal swelling and shrinkage of soil

All clays react to the presence of water by slowly absorbing it, making the soil increase in volume (see table below). The degree of increase varies considerably between different clays, as does the degree of decrease during the subsequent drying out caused by fair weather periods. Because of the low absorption and expulsion rate, this phenomenon will not usually be noticeable unless there are prolonged rainy or dry periods, usually of weeks or months, depending on the land and soil characteristics.

The swelling of soil creates an upward force on the footings of the building, and shrinkage creates subsidence that takes away the support needed by the footing to retain equilibrium.

Shear failure

This phenomenon occurs when the foundation soil does not have sufficient strength to support the weight of the footing. There are two major post-construction causes:

- Significant load increase.
- Reduction of lateral support of the soil under the footing due to erosion or excavation.

In clay soil, shear failure can be caused by saturation of the soil adjacent to or under the footing.

GENERAL DEFINITIONS OF SITE CLASSES

Class	Foundation
A	Most sand and rock sites with little or no ground movement from moisture changes
S	Slightly reactive clay sites, which may experience only slight ground movement from moisture changes
M	Moderately reactive clay or silt sites, which may experience moderate ground movement from moisture changes
H1	Highly reactive clay sites, which may experience high ground movement from moisture changes
H2	Highly reactive clay sites, which may experience very high ground movement from moisture changes
E	Extremely reactive sites, which may experience extreme ground movement from moisture changes

Notes

1. Where controlled fill has been used, the site may be classified A to E according to the type of fill used.
2. Filled sites. Class P is used for sites which include soft fills, such as clay or silt or loose sands; landslide; mine subsidence; collapsing soils; soil subject to erosion; reactive sites subject to abnormal moisture conditions or sites which cannot be classified otherwise.
3. Where deep-seated moisture changes exist on sites at depths of 3 m or greater, further classification is needed for Classes M to E (M-D, H1-D, H2-D and E-D).

Tree root growth

Trees and shrubs that are allowed to grow in the vicinity of footings can cause foundation soil movement in two ways:

- Roots that grow under footings may increase in cross-sectional size, exerting upward pressure on footings.
- Roots in the vicinity of footings will absorb much of the moisture in the foundation soil, causing shrinkage or subsidence.

Unevenness of Movement

The types of ground movement described above usually occur unevenly throughout the building's foundation soil. Settlement due to construction tends to be uneven because of:

- Differing compaction of foundation soil prior to construction.
- Differing moisture content of foundation soil prior to construction.

Movement due to non-construction causes is usually more uneven still. Erosion can undermine a footing that traverses the flow or can create the conditions for shear failure by eroding soil adjacent to a footing that runs in the same direction as the flow.

Saturation of clay foundation soil may occur where subfloor walls create a dam that makes water pond. It can also occur wherever there is a source of water near footings in clay soil. This leads to a severe reduction in the strength of the soil which may create local shear failure.

Seasonal swelling and shrinkage of clay soil affects the perimeter of the building first, then gradually spreads to the interior. The swelling process will usually begin at the uphill extreme of the building, or on the weather side where the land is flat. Swelling gradually reaches the interior soil as absorption continues. Shrinkage usually begins where the sun's heat is greatest.

Effects of Uneven Soil Movement on Structures

Erosion and saturation

Erosion removes the support from under footings, tending to create subsidence of the part of the structure under which it occurs. Brickwork walls will resist the stress created by this removal of support by bridging the gap or cantilevering until the bricks or the mortar bedding fail. Older masonry has little resistance. Evidence of failure varies according to circumstances and symptoms may include:

- Step cracking in the mortar beds in the body of the wall or above/below openings such as doors or windows.
- Vertical cracking in the bricks (usually but not necessarily in line with the vertical beds or perpend).

Isolated piers affected by erosion or saturation of foundations will eventually lose contact with the bearers they support and may tilt or fall over. The floors that have lost this support will become bouncy, sometimes rattling ornaments etc.

Seasonal swelling/shrinkage in clay

Swelling foundation soil due to rainy periods first lifts the most exposed extremities of the footing system, then the remainder of the perimeter footings while gradually permeating inside the building footprint to lift internal footings. This swelling first tends to create a dish effect, because the external footings are pushed higher than the internal ones.

The first noticeable symptom may be that the floor appears slightly dished. This is often accompanied by some doors binding on the floor or the door head, together with some cracking of cornice mitres. In buildings with timber flooring supported by bearers and joists, the floor can be bouncy. Externally there may be visible dishing of the hip or ridge lines.

As the moisture absorption process completes its journey to the innermost areas of the building, the internal footings will rise. If the spread of moisture is roughly even, it may be that the symptoms will temporarily disappear, but it is more likely that swelling will be uneven, creating a difference rather than a disappearance in symptoms. In buildings with timber flooring supported by bearers and joists, the isolated piers will rise more easily than the strip footings or piers under walls, creating noticeable doming of flooring.

As the weather pattern changes and the soil begins to dry out, the external footings will be first affected, beginning with the locations where the sun's effect is strongest. This has the effect of lowering the

Trees can cause shrinkage and damage

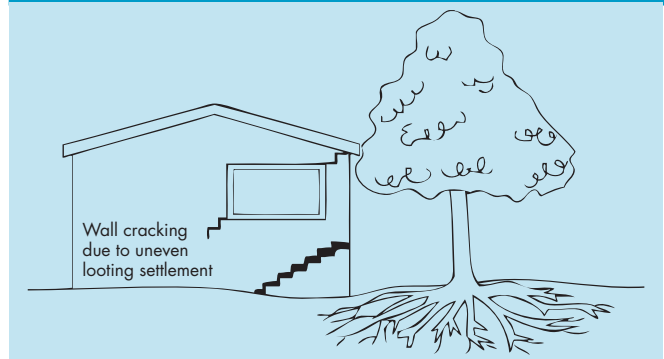

external footings. The doming is accentuated and cracking reduces or disappears where it occurred because of dishing, but other cracks open up. The roof lines may become convex.

Doming and dishing are also affected by weather in other ways. In areas where warm, wet summers and cooler dry winters prevail, water migration tends to be toward the interior and doming will be accentuated, whereas where summers are dry and winters are cold and wet, migration tends to be toward the exterior and the underlying propensity is toward dishing.

Movement caused by tree roots

In general, growing roots will exert an upward pressure on footings, whereas soil subject to drying because of tree or shrub roots will tend to remove support from under footings by inducing shrinkage.

Complications caused by the structure itself

Most forces that the soil causes to be exerted on structures are vertical – i.e. either up or down. However, because these forces are seldom spread evenly around the footings, and because the building resists uneven movement because of its rigidity, forces are exerted from one part of the building to another. The net result of all these forces is usually rotational. This resultant force often complicates the diagnosis because the visible symptoms do not simply reflect the original cause. A common symptom is binding of doors on the vertical member of the frame.

Effects on full masonry structures

Brickwork will resist cracking where it can. It will attempt to span areas that lose support because of subsided foundations or raised points. It is therefore usual to see cracking at weak points, such as openings for windows or doors.

In the event of construction settlement, cracking will usually remain unchanged after the process of settlement has ceased.

With local shear or erosion, cracking will usually continue to develop until the original cause has been remedied, or until the subsidence has completely neutralised the affected portion of footing and the structure has stabilised on other footings that remain effective.

In the case of swell/shrink effects, the brickwork will in some cases return to its original position after completion of a cycle, however it is more likely that the rotational effect will not be exactly reversed, and it is also usual that brickwork will settle in its new position and will resist the forces trying to return it to its original position. This means that in a case where swelling takes place after construction and cracking occurs, the cracking is likely to at least partly remain after the shrink segment of the cycle is complete. Thus, each time the cycle is repeated, the likelihood is that the cracking will become wider until the sections of brickwork become virtually independent.

With repeated cycles, once the cracking is established, if there is no other complication, it is normal for the incidence of cracking to stabilise, as the building has the articulation it needs to cope with the problem. This is by no means always the case, however, and monitoring of cracks in walls and floors should always be treated seriously.

Upheaval caused by growth of tree roots under footings is not a simple vertical shear stress. There is a tendency for the root to also exert lateral forces that attempt to separate sections of brickwork after initial cracking has occurred.

The normal structural arrangement is that the inner leaf of brickwork in the external walls and at least some of the internal walls (depending on the roof type) comprise the load-bearing structure on which any upper floors, ceilings and the roof are supported. In these cases, it is internally visible cracking that should be the main focus of attention, however there are a few examples of dwellings whose external leaf of masonry plays some supporting role, so this should be checked if there is any doubt. In any case, externally visible cracking is important as a guide to stresses on the structure generally, and it should also be remembered that the external walls must be capable of supporting themselves.

Effects on framed structures

Timber or steel framed buildings are less likely to exhibit cracking due to swell/shrink than masonry buildings because of their flexibility. Also, the doming/dishing effects tend to be lower because of the lighter weight of walls. The main risks to framed buildings are encountered because of the isolated pier footings used under walls. Where erosion or saturation causes a footing to fall away, this can double the span which a wall must bridge. This additional stress can create cracking in wall linings, particularly where there is a weak point in the structure caused by a door or window opening. It is, however, unlikely that framed structures will be so stressed as to suffer serious damage without first exhibiting some or all of the above symptoms for a considerable period. The same warning period should apply in the case of upheaval. It should be noted, however, that where framed buildings are supported by strip footings there is only one leaf of brickwork and therefore the externally visible walls are the supporting structure for the building. In this case, the subfloor masonry walls can be expected to behave as full brickwork walls.

Effects on brick veneer structures

Because the load-bearing structure of a brick veneer building is the frame that makes up the interior leaf of the external walls plus perhaps the internal walls, depending on the type of roof, the building can be expected to behave as a framed structure, except that the external masonry will behave in a similar way to the external leaf of a full masonry structure.

Water Service and Drainage

Where a water service pipe, a sewer or stormwater drainage pipe is in the vicinity of a building, a water leak can cause erosion, swelling or saturation of susceptible soil. Even a minuscule leak can be enough to saturate a clay foundation. A leaking tap near a building can have the same effect. In addition, trenches containing pipes can become watercourses even though backfilled, particularly where broken rubble is used as fill. Water that runs along these trenches can be responsible for serious erosion, interstrata seepage into subfloor areas and saturation.

Pipe leakage and trench water flows also encourage tree and shrub roots to the source of water, complicating and exacerbating the problem. Poor roof plumbing can result in large volumes of rainwater being concentrated in a small area of soil:

- Incorrect falls in roof guttering may result in overflows, as may gutters blocked with leaves etc.

- Corroded guttering or downpipes can spill water to ground.
- Downpipes not positively connected to a proper stormwater collection system will direct a concentration of water to soil that is directly adjacent to footings, sometimes causing large-scale problems such as erosion, saturation and migration of water under the building.

Seriousness of Cracking

In general, most cracking found in masonry walls is a cosmetic nuisance only and can be kept in repair or even ignored. The table below is a reproduction of Table C1 of AS 2870-2011.

AS 2870-2011 also publishes figures relating to cracking in concrete floors, however because wall cracking will usually reach the critical point significantly earlier than cracking in slabs, this table is not reproduced here.

Prevention/Cure

Plumbing

Where building movement is caused by water service, roof plumbing, sewer or stormwater failure, the remedy is to repair the problem. It is prudent, however, to consider also rerouting pipes away from the building where possible, and relocating taps to positions where any leakage will not direct water to the building vicinity. Even where gully traps are present, there is sometimes sufficient spill to create erosion or saturation, particularly in modern installations using smaller diameter PVC fixtures. Indeed, some gully traps are not situated directly under the taps that are installed to charge them, with the result that water from the tap may enter the backfilled trench that houses the sewer piping. If the trench has been poorly backfilled, the water will either pond or flow along the bottom of the trench. As these trenches usually run alongside the footings and can be at a similar depth, it is not hard to see how any water that is thus directed into a trench can easily affect the foundation's ability to support footings or even gain entry to the subfloor area.

Ground drainage

In all soils there is the capacity for water to travel on the surface and below it. Surface water flows can be established by inspection during and after heavy or prolonged rain. If necessary, a grated drain system connected to the stormwater collection system is usually an easy solution.

It is, however, sometimes necessary when attempting to prevent water migration that testing be carried out to establish watertable height and subsoil water flows. This subject is referred to in BTF 19 and may properly be regarded as an area for an expert consultant.

Protection of the building perimeter

It is essential to remember that the soil that affects footings extends well beyond the actual building line. Watering of garden plants, shrubs and trees causes some of the most serious water problems.

For this reason, particularly where problems exist or are likely to occur, it is recommended that an apron of paving be installed around as much of the building perimeter as necessary. This paving should

CLASSIFICATION OF DAMAGE WITH REFERENCE TO WALLS

Description of typical damage and required repair	Approximate crack width limit (see Note 3)	Damage category
Hairline cracks	<0.1 mm	0
Fine cracks which do not need repair	<1 mm	1
Cracks noticeable but easily filled. Doors and windows stick slightly.	<5 mm	2
Cracks can be repaired and possibly a small amount of wall will need to be replaced. Doors and windows stick. Service pipes can fracture. Weathertightness often impaired.	5–15 mm (or a number of cracks 3 mm or more in one group)	3
Extensive repair work involving breaking-out and replacing sections of walls, especially over doors and windows. Window and door frames distort. Walls lean or bulge noticeably, some loss of bearing in beams. Service pipes disrupted.	15–25 mm but also depends on number of cracks	4

Gardens for a reactive site

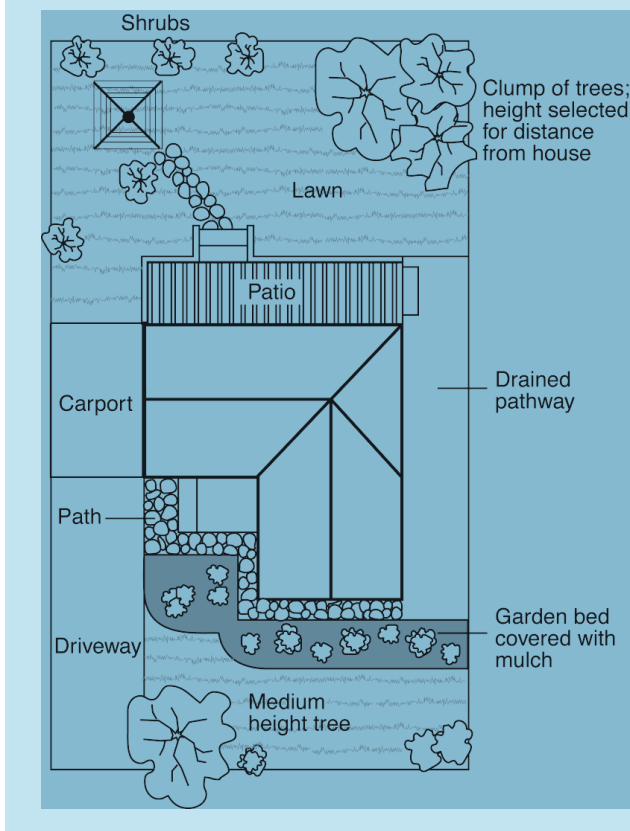

extend outwards a minimum of 900 mm (more in highly reactive soil) and should have a minimum fall away from the building of 1:60. The finished paving should be no less than 100 mm below brick vent bases.

It is prudent to relocate drainage pipes away from this paving, if possible, to avoid complications from future leakage. If this is not practical, earthenware pipes should be replaced by PVC and backfilling should be of the same soil type as the surrounding soil and compacted to the same density.

Except in areas where freezing of water is an issue, it is wise to remove taps in the building area and relocate them well away from the building – preferably not uphill from it (see BTF 19).

It may be desirable to install a grated drain at the outside edge of the paving on the uphill side of the building. If subsoil drainage is needed this can be installed under the surface drain.

Condensation

In buildings with a subfloor void such as where bearers and joists support flooring, insufficient ventilation creates ideal conditions for condensation, particularly where there is little clearance between the floor and the ground. Condensation adds to the moisture already present in the subfloor and significantly slows the process of drying out. Installation of an adequate subfloor ventilation system, either natural or mechanical, is desirable.

Warning: Although this Building Technology File deals with cracking in buildings, it should be said that subfloor moisture can result in the development of other problems, notably:

- Water that is transmitted into masonry, metal or timber building elements causes damage and/or decay to those elements.
- High subfloor humidity and moisture content create an ideal environment for various pests, including termites and spiders.
- Where high moisture levels are transmitted to the flooring and walls, an increase in the dust mite count can ensue within the living areas. Dust mites, as well as dampness in general, can be a health hazard to inhabitants, particularly those who are abnormally susceptible to respiratory ailments.

The garden

The ideal vegetation layout is to have lawn or plants that require only light watering immediately adjacent to the drainage or paving edge, then more demanding plants, shrubs and trees spread out in that order.

Overwatering due to misuse of automatic watering systems is a common cause of saturation and water migration under footings. If it is necessary to use these systems, it is important to remove garden beds to a completely safe distance from buildings.

Existing trees

Where a tree is causing a problem of soil drying or there is the existence or threat of upheaval of footings, if the offending roots are subsidiary and their removal will not significantly damage the tree, they should be severed and a concrete or metal barrier placed vertically in the soil to prevent future root growth in the direction of the building. If it is not possible to remove the relevant roots without damage to the tree, an application to remove the tree should be made to the local authority. A prudent plan is to transplant likely offenders before they become a problem.

Information on trees, plants and shrubs

State departments overseeing agriculture can give information regarding root patterns, volume of water needed and safe distance from buildings of most species. Botanic gardens are also sources of information. For information on plant roots and drains, see Building Technology File 17.

Excavation

Excavation around footings must be properly engineered. Soil supporting footings can only be safely excavated at an angle that allows the soil under the footing to remain stable. This angle is called the angle of repose (or friction) and varies significantly between soil types and conditions. Removal of soil within the angle of repose will cause subsidence.

Remediation

Where erosion has occurred that has washed away soil adjacent to footings, soil of the same classification should be introduced and compacted to the same density. Where footings have been undermined, augmentation or other specialist work may be required. Remediation of footings and foundations is generally the realm of a specialist consultant.

Where isolated footings rise and fall because of swell/shrink effect, the homeowner may be tempted to alleviate floor bounce by filling the gap that has appeared between the bearer and the pier with blocking. The danger here is that when the next swell segment of the cycle occurs, the extra blocking will push the floor up into an accentuated dome and may also cause local shear failure in the soil. If it is necessary to use blocking, it should be by a pair of fine wedges and monitoring should be carried out fortnightly.

This BTF was prepared by John Lewer FAIB, MIAMA, Partner, Construction Diagnosis.

The information in this and other issues in the series was derived from various sources and was believed to be correct when published.

The information is advisory. It is provided in good faith and not claimed to be an exhaustive treatment of the relevant subject.

Further professional advice needs to be obtained before taking any action based on the information provided.

Distributed by

CSIRO PUBLISHING PO Box 1139, Collingwood 3066, Australia

Tel (03) 9662 7666 Fax (03) 9662 7555 www.publish.csiro.au

Email: publishing.sales@csiro.au

© CSIRO 2003. Unauthorised copying of this Building Technology File is prohibited